



**Electric Automation**  
Automation specialists

Referência: WKLG 1650 FT  
Código: 6227155

bandeja palmo de largura, lado  
perfurado, 160x500x6000, galvanizado  
a quente, DIN EN ISO 1461 Aço St

A partir de [Electric Automation Network](#)

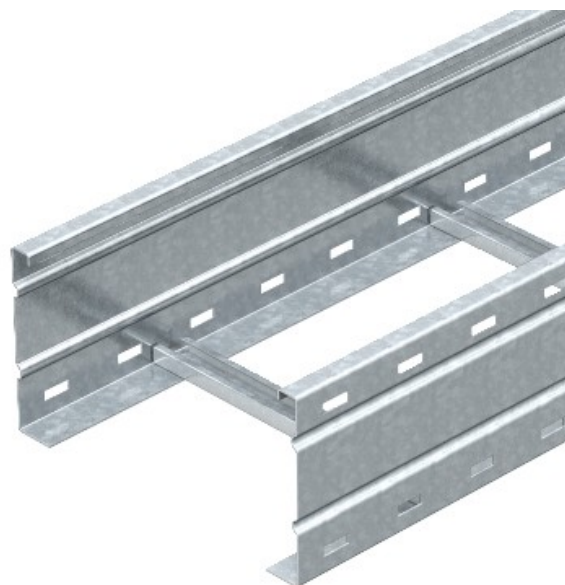

WKLG 160 = extensão de largura cabo escada com laterais perfuradas trilhos de lado e altura de 160 mm.