



**Electric Automation**  
Automation specialists

Referência: G-GRM 150 100 FT  
Código: 6005529

bandeja grade G-GRM, 150x100x3000,  
galvanizado a quente, DIN EN ISO 1461  
Aço St

A partir de Electric Automation Network

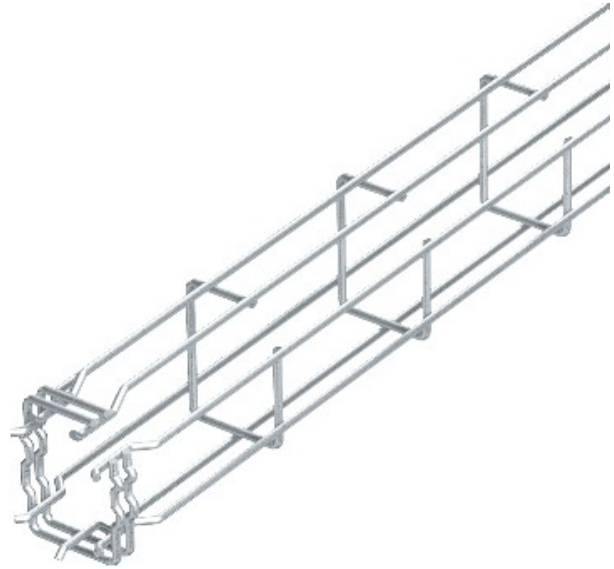

Escudo magnético isolamento de 15 dB.