

Programmable Multi Axis Controller

CK3M



Control with
nanoscale precision



Maximize your machine's performance

Performing precise linear motor drive control and nanoscale positioning, the PMAC (Programmable Multi Axis Controller) has been appreciated by manufacturers of semiconductor manufacturing equipment and other leading-edge equipment. Omron now offers a next generation motion controller CK3M that packs PMAC's superior motion control capability, multi-vendor connectivity, and flexible development capability into its compact design. The CK3M removes constraints and barriers and maximizes your machine's capabilities.

Rapid

[Nano-level high-precision control]

Ultra-fast calculation takes high-speed, high-precision control to a new dimension. Its overwhelming calculation speed boosts your machine's precision.

Ultra-high-speed synchronous control

The CK3M delivers world-beating*1 output speeds : 50 μ s/5 axes. Ultra-high-speed feedback control enables precise path control in precision machining.

*1. Omron survey as of March 2018.

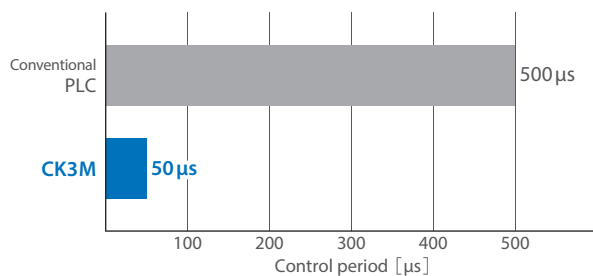

Fast servo cycle time for precise path control

The CK3M receives a feedback value and generates a command value to adjust to the target value at a high speed, providing more precise path control.

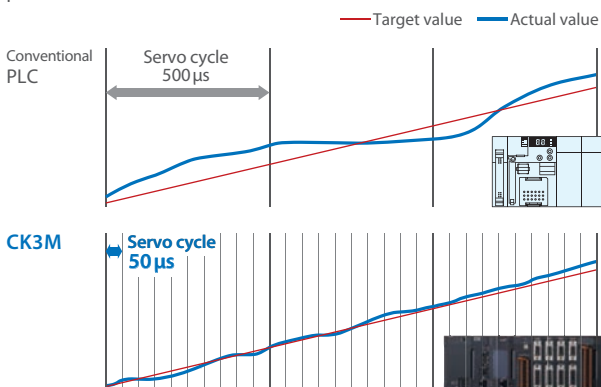

Fast feedback and correction

Flexible

[Optimize system configuration]

You can freely use multi-vendor actuators and encoders, which maximizes your machine's performance.

Advanced encoders

The capability to accept the A/B phase signals and parallel binary signals from serial data interfaces enables high-precision positioning using advanced encoders.

Various actuators

Axes can be controlled by analog commands (DAC and direct PWM*2). The CK3M can interface with virtually any type of motor including voice coil motors and linear motors to provide precise machine operation.

*2. Direct PWM will be available soon.

Conventional system

- Fully synchronized control is difficult because multiple controllers are used
- Available actuators are limited depending on controller

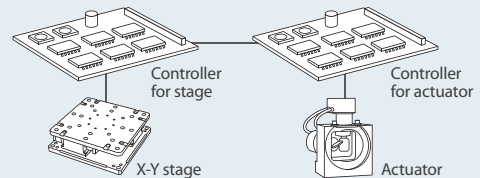

CK3M

- One controller provides high-precision synchronous control
- A wide variety of actuators can be controlled, increasing machine performance

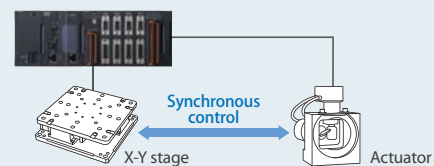

EtherCAT® interface

The built-in EtherCAT® communications port is used to connect EtherCAT® slaves including servo drives, inverters, vision systems, sensors, and I/O. Flexible systems can be configured.



Capable

[Continuous development through customization]

The PMAC architecture with flexible function development capability helps you realize your ideas such as incorporation of your own algorithms.

Programming flexibility

G-Code, ANSI C, or original programming language allows you to create complex and advanced algorithms.



You can create programs to control robots that follow complex paths.



In addition to customizing standard G-Code functions, you can also incorporate your own G-Code functions.

Custom servo algorithms

Full closed loop control by servo drives can be incorporated into the controller. You can customize machine control such as vibration suppression optimized for the machine mechanism.

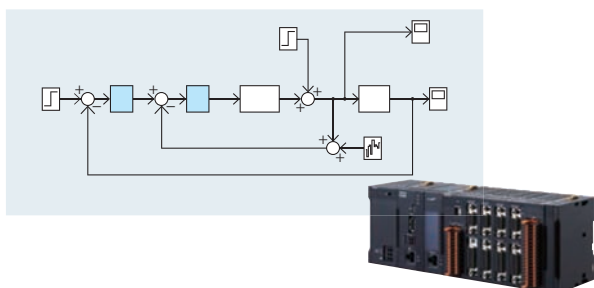

Easy

[Easy to use like a PLC]

Its compact design facilitates installation in the control panel. Unit connection without tools and DIN track mounting make installation and replacement more efficient.

Modular design

The modular design allows you to freely combine the CK3M with expansion units*3 to enable a variety of applications.

*3. Up to two axial interface units can be mounted to the CK3M-CPU1□1.



Tool-free connection & compact size



Units can be easily connected without tools. Its compact design*4 reduces control panel size.

Approx. **1/3** volume of UMAC, saving space in control panels.

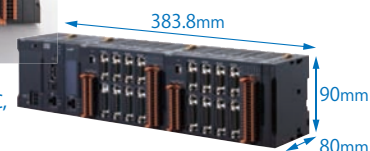

*4. CK3W-PD + CK3M-CPU + two CK3W-AX

DIN track mounting



Units can be easily mounted on a DIN track in a control system.

High-precision control of precision mechanisms

Used in conjunction with advanced actuators, encoders, and precision mechanisms, the CK3M enables a wide variety of applications where both speed and accuracy are required.

Rapid

Nano-level high-precision control

Flexible

Optimize system configuration



Capable

Continuous development through customization

Easy

Easy to use like a PLC

Application



Processing/ pressing machines

High-speed, high-precision processing for electric discharge machines, water jet machines, laser processing machines, grinders, and precision pressing machines

Mechanism

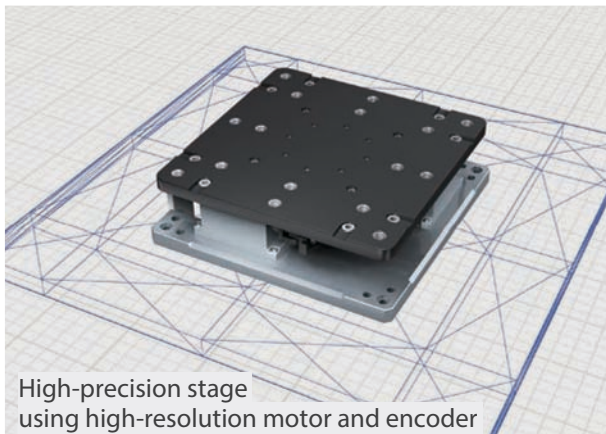

High-precision stage using high-resolution motor and encoder

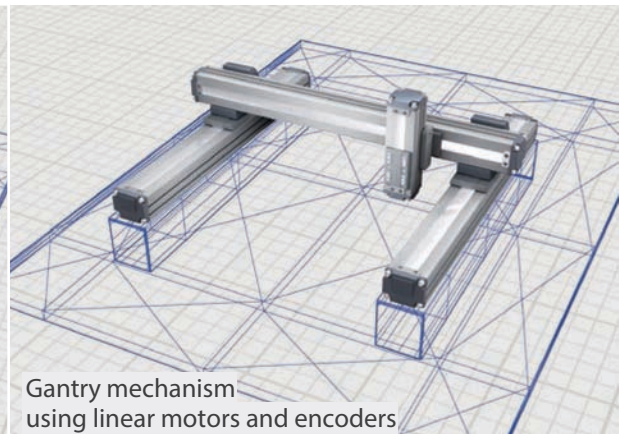

Gantry mechanism using linear motors and encoders

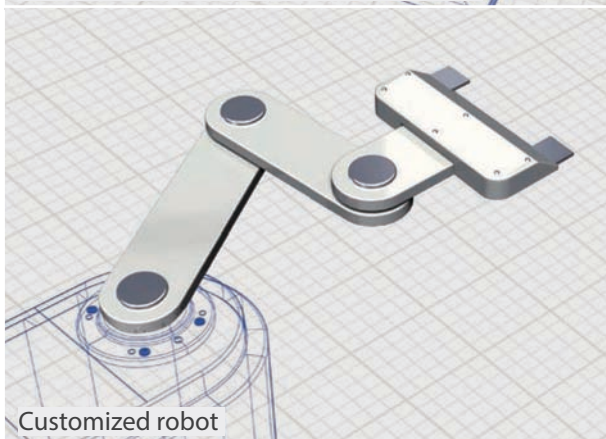

Customized robot

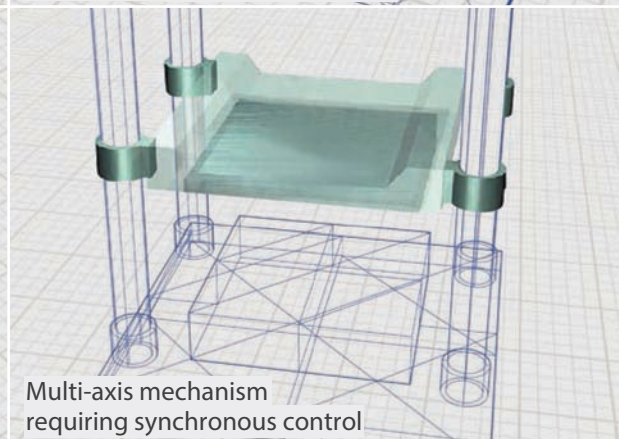

Multi-axis mechanism requiring synchronous control



Semiconductor/ FPD manufacturing/ inspection machines

Extremely precise motion for exposure machines, linear coaters, dispensers, and wafer inspection machines



Robots

Complex mechanical control for machines using customized robots

Integrated development environment (IDE)

Power PMAC IDE

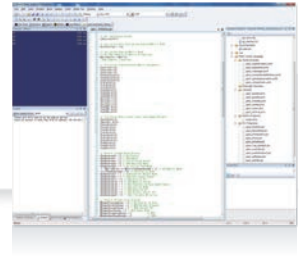

The Power PMAC IDE is an integrated development environment based on Microsoft® Visual Studio® that development engineers use as a development platform around the world. This IDE integrates motion programming for PMAC, motor setup and tuning, debugging, and troubleshooting. Lightweight, sophisticated GUI provides intuitive user operations, which helps you improve application development productivity.

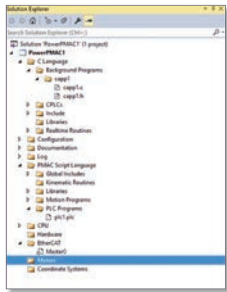

Microsoft® Visual Studio® based integrated development environment

Assignment settings for CPU, hardware, EtherCAT®, coordinate systems, and motors can be accessed from one screen.



ANSI C or original programming language

In addition to programming in ANSI C and C-language like original programming language, G-Code can be used to write subroutines for G-Code actions.

Easy tuning

Autotuning facilitates tuning of motors. You can fine tune motors through intuitive operations.

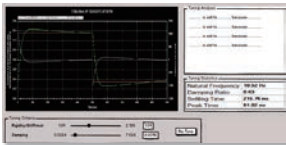

Simple setting

Just follow the workflow to set up motors.

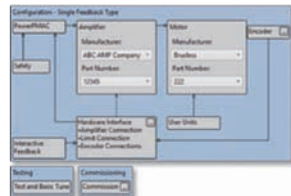

Troubleshooting

Possible solutions to your problems are suggested.

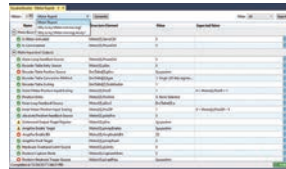

Debugger

It provides the Microsoft® Visual Studio® style debugger for Script PLC programs and C background programs.

IP Protection

IP Protection allows engineers to protect their intellectual property by encrypting script programs

An engineer can encrypt the script programs per file and pass the project on to another engineer. The engineer who takes the project can add their own logic but cannot list or view the code encrypted by another engineer. The encryption is three-level password protected: OEM builders, independent integrators, and users can share a project securely and flexibly.

Three-level IP Protection

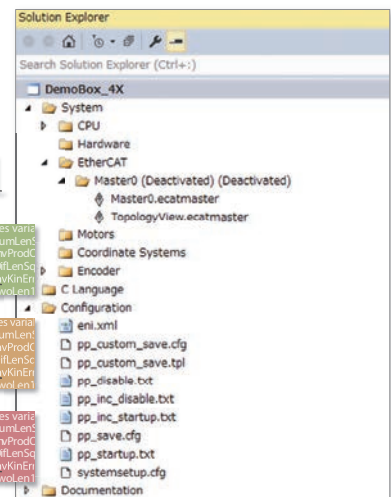
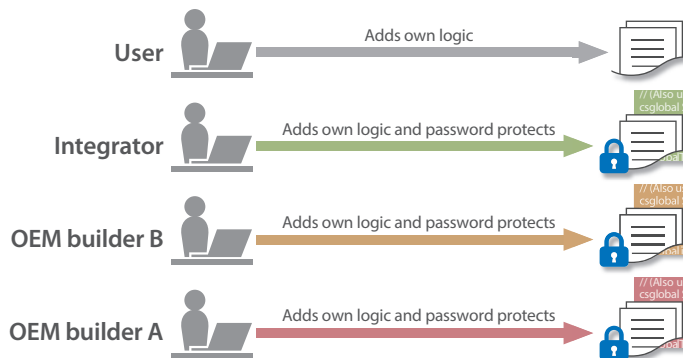

Specifications

Motion control	Max. no. of controlled axes	16 (EtherCAT® : 8, 2 axial interface units : 8)
	Motion control period	50 μs / 5 axes or more
	Control method	Analog (Filtered PWM, True DAC) , pulse
Interface		Ethernet port, EtherCAT® port (CPU option)
Feedback		AB phase, serial encoders*
Memory	RAM	1 GB
	Flash	1 GB

System configuration

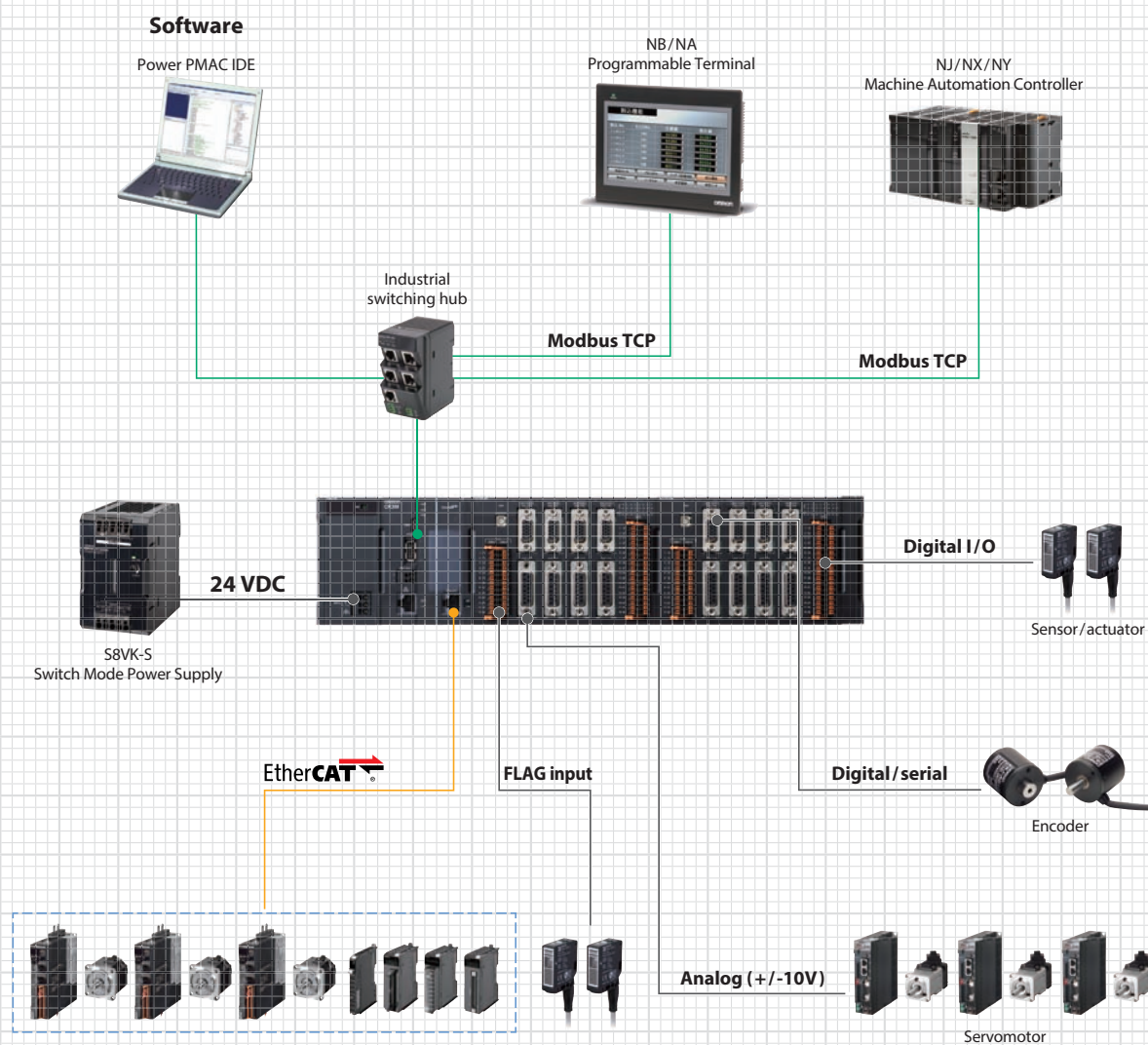

PMAC Series family

■ Standard Models

CPU Units

Product name	Memory capacity	EtherCAT® port	Max. no. of controlled axes via EtherCAT® port	Expansion	Model
CK3M-CPU1□1 CPU Unit*	RAM: 1 GB Built-In flash memory: 1 GB	None	—	• Up to two axial interface units can be connected • Expansion units can be connected	CK3M-CPU101
		EtherCAT®: 1 port (DC sync)	4		CK3M-CPU111
			8		CK3M-CPU121

* One End Cover is provided with the CK3M-CPU1□1 CPU Unit. The CK3W-TER11 End Cover for CK3M-CPU1□1 is sold separately if required.

Axial Interface Units

Product name	Amplifier interface	Pulse output	Encoder interface	Output type	Model
Axial Interface Unit for CK3M-CPU1□1	DA output (Filtered PWM)	Pulse output method: Pulse + direction or phase difference	Pulse encoder Serial encoder	NPN type	CK3W-AX1414N
	DA output (True DAC)				CK3W-AX1515N
	DA output (Filtered PWM)	Pulse output type: Line driver		PNP type	CK3W-AX1414P
	DA output (True DAC)				CK3W-AX1515P

Power Supply Unit

Product name	Specifications	Model
Power Supply Unit for CK3M-CPU1□1	Rated output voltage: 5 VDC / 24 VDC, maximum output current: 8 A (5 VDC)	CK3W-PD048

- Microsoft® and Visual Studio® are either registered trademarks or trademarks of Microsoft Corporation in the United States and/or other countries.
- EtherCAT® is a registered trademark and patented technology, licensed by Beckhoff Automation GmbH, Germany.
- Microsoft product screen shot(s) reprinted with permission from Microsoft Corporation.
- Other company names and product names in this document are the trademarks or registered trademarks of their respective companies.
- The product photographs and figures that are used in this catalog may vary somewhat from the actual products.
- PMAC is an abbreviation for Programmable Multi Axis Controller.
- Some images are used under license from Shutterstock.com.

Note: Do not use this document to operate the Unit.

OMRON Corporation Industrial Automation Company
Kyoto, JAPAN

Contact: www.ia.omron.com

Regional Headquarters

OMRON EUROPE B.V.

Wegalaan 67-69, 2132 JD Hoofddorp
The Netherlands
Tel: (31)2356-81-300/Fax: (31)2356-81-388

OMRON ELECTRONICS LLC

2895 Greenspoint Parkway, Suite 200
Hoffman Estates, IL 60169 U.S.A.
Tel: (1) 847-843-7900/Fax: (1) 847-843-7787

OMRON ASIA PACIFIC PTE. LTD.

No. 438A Alexandra Road # 05-05/08 (Lobby 2),
Alexandra Technopark,
Singapore 119967
Tel: (65) 6835-3011/Fax: (65) 6835-2711

OMRON (CHINA) CO., LTD.

Room 2211, Bank of China Tower,
200 Yin Cheng Zhong Road,
PuDong New Area, Shanghai, 200120, China
Tel: (86) 21-5037-2222/Fax: (86) 21-5037-2200

Authorized Distributor:

© OMRON Corporation 2018 All Rights Reserved.
In the interest of product improvement,
specifications are subject to change without notice.

CSM_1_2_0119
Cat. No. R196-E1-02

0618 (0318)