

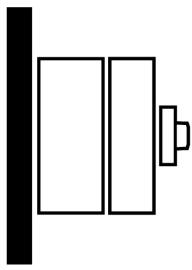
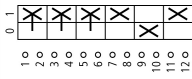
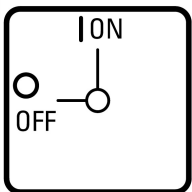

**Main switch, T3, 32 A, surface mounting, 3 contact unit(s), 3 pole, 2 N/O, 1 N/C, Emergency switching off function, With red rotary handle and yellow locking ring, UL/CSA**

**Part no. T3-3-15683/I2/SVB-NA**  
**Catalog No. 255912**

### Delivery program

|  |                |                 |  |
|--|----------------|-----------------|--|
| Product range                                      |                |                 | Main switch<br>maintenance switch<br>Repair switch                                   |
| Part group reference                               |                |                 | T3   |
| Stop Function                                      |                |                 | Emergency switching off function   |
| Notes  |                |                 | With red rotary handle and yellow locking ring                                       |
| Number of poles                                    |                |                 | 3 pole   |
| <b>Auxiliary contacts</b>                          |                |                 |  |
|  |                | N/O             | 2  |
|  |                | N/C             | 1  |
| Degree of Protection                               |                |                 | IP65   |
|  |                |                 | <b>totally insulated</b>   |
| Design   |                |                 | surface mounting   |
|  |                |                 |  |
| Contact sequence                                   |                |                 |  |
| Switching angle                                    |                | °               | 90   |
| Design number                                      |                |                 | 15683  |
| Function   |                |                 |  |
| <b>Motor rating AC-23A, 50 - 60 Hz</b>             |                |                 |  |
| 400 V  | P              | kW              | 15   |
| Rated uninterrupted current                        | I <sub>u</sub> | A               | 32   |
| Note on rated uninterrupted current I <sub>u</sub> |                |                 | Rated uninterrupted current I <sub>u</sub> is specified for max. cross-section.      |
| Number of contact units                            |                | contact unit(s) | 3  |

### Technical data

|                   |  |  |  |
|-------------------|--|--|--|
| <b>General</b>    |  |  |  |
| Standards         |  |  | IEC/EN 60947, VDE 0660, IEC/EN 60204, CSA, UL<br>Switch-disconnector according to IEC/EN 60947-3 |
| Climatic proofing |  |  | Damp heat, constant, to IEC 60068-2-78   |

|                                       |           |      |                                      |
|---------------------------------------|-----------|------|--------------------------------------|
|                                       |           |      | Damp heat, cyclic, to IEC 60068-2-30 |
| Ambient temperature                   |           |      |                                      |
| Enclosed                              |           | °C   | -25 - +40                            |
| Overtoltage category/pollution degree |           |      | III/3                                |
| Rated impulse withstand voltage       | $U_{imp}$ | V AC | 6000                                 |
| Mechanical shock resistance           |           | g    | 12                                   |
| Mounting position                     |           |      | As required                          |

## Contacts

|   |          |           |  |
|---|----------|-----------|--|
| Mechanical variables                                |          |           |  |
| Number of poles                                     |          |           | 3 pole   |
| Auxiliary contacts                                  |          |           |  |
|   |          | N/O       | 2  |
|   |          | N/C       | 1  |
| Electrical characteristics                          |          |           |  |
| Rated operational voltage                           | $U_e$    | V AC      | 690  |
| Rated uninterrupted current                         | $I_u$    | A         | 32   |
| Note on rated uninterrupted current $I_u$           |          |           | Rated uninterrupted current $I_u$ is specified for max. cross-section. |
| Load rating with intermittent operation, class 12   |          |           |  |
| AB 25 % DF  |          | $x I_e$   | 2  |
| AB 40 % DF  |          | $x I_e$   | 1.6  |
| AB 60 % DF  |          | $x I_e$   | 1.3  |
| Short-circuit rating                                |          |           |  |
| Fuse  |          | A gG/gL   | 35   |
| Rated short-time withstand current (1 s current)    | $I_{cw}$ | $A_{rms}$ | 650  |
| Note on rated short-time withstand current $I_{cw}$ |          |           | Current for a time of 1 second   |
| Rated conditional short-circuit current             | $I_q$    | kA        | 1  |

## Switching capacity

|  |              |          |       |
|--|--------------|----------|-------|
| $\cos \varphi$ rated making capacity as per IEC 60947-3        |              | A        | 320   |
| Rated breaking capacity $\cos \varphi$ to IEC 60947-3          |              | A        |       |
| 230 V  |              | A        | 260   |
| 400/415 V  |              | A        | 260   |
| 500 V  |              | A        | 240   |
| 690 V  |              | A        | 170   |
| Safe isolation to EN 61140                                     |              |          |       |
| between the contacts   |              | V AC     | 440   |
| Current heat loss per contact at $I_e$                         |              | W        | 1.1   |
| Current heat loss per auxiliary circuit at $I_e$ (AC-15/230 V) |              | CO       | 1.1   |
| Lifespan, mechanical   | Operations   | $x 10^6$ | > 0.5 |
| Maximum operating frequency                                    | Operations/h |          | 1200  |
| AC   |              |          |       |
| AC-3   |              |          |       |
| Rating, motor load switch                                      | P            | kW       |       |
| 220 V 230 V  | P            | kW       | 5.5   |
| 230 V Star-delta   | P            | kW       | 7.5   |
| 400 V 415 V  | P            | kW       | 11    |
| 400 V Star-delta   | P            | kW       | 15    |
| 500 V  | P            | kW       | 15    |
| 500 V Star-delta   | P            | kW       | 18.5  |
| 690 V  | P            | kW       | 11    |
| 690 V Star-delta   | P            | kW       | 22    |
| Rated operational current motor load switch                    |              |          |       |
| 230 V  | $I_e$        | A        | 23.7  |
| 230 V star-delta   | $I_e$        | A        | 32    |
| 400V 415 V   | $I_e$        | A        | 23.7  |
| 400 V star-delta   | $I_e$        | A        | 32    |

|   |                   |                 |  |
|---|-------------------|-----------------|--|
| 500 V   | I <sub>e</sub>    | A               | 23.7   |
| 500 V star-delta                              | I <sub>e</sub>    | A               | 32   |
| 690 V   | I <sub>e</sub>    | A               | 14.7   |
| 690 V star-delta                              | I <sub>e</sub>    | A               | 25.5   |
| <b>AC-21A</b>                                 |                   |                 |  |
| Rated operational current switch              |                   |                 |  |
| 440 V   | I <sub>e</sub>    | A               | 32   |
| <b>AC-23A</b>                                 |                   |                 |  |
| Motor rating AC-23A, 50 - 60 Hz               |                   |                 |  |
| 230 V   | P                 | kW              | 7.5  |
| 400 V 415 V                                   | P                 | kW              | 15   |
| 500 V   | P                 | kW              | 15   |
| 690 V   | P                 | kW              | 15   |
| Rated operational current motor load switch   |                   |                 |  |
| 230 V   | I <sub>e</sub>    | A               | 32   |
| 400 V 415 V                                   | I <sub>e</sub>    | A               | 32   |
| 500 V   | I <sub>e</sub>    | A               | 26.4   |
| 690 V   | I <sub>e</sub>    | A               | 17   |
| <b>DC</b>                                     |                   |                 |  |
| DC-1, Load-break switches L/R = 1 ms          |                   |                 |  |
| Rated operational current                     | I <sub>e</sub>    | A               | 25   |
| Voltage per contact pair in series            |                   | V               | 60   |
| <b>DC-21A</b>                                 |                   |                 |  |
| Rated operational current                     | I <sub>e</sub>    | A               | 1  |
| Contacts                                      |                   | Quantity        | 1  |
| <b>DC-23A, motor load switch L/R = 15 ms</b>  |                   |                 |  |
| 24 V  |                   |                 |  |
| Rated operational current                     | I <sub>e</sub>    | A               | 25   |
| Contacts                                      |                   | Quantity        | 1  |
| 48 V  |                   |                 |  |
| Rated operational current                     | I <sub>e</sub>    | A               | 25   |
| Contacts                                      |                   | Quantity        | 2  |
| 60 V  |                   |                 |  |
| Rated operational current                     | I <sub>e</sub>    | A               | 25   |
| Contacts                                      |                   | Quantity        | 3  |
| 120 V   |                   |                 |  |
| Rated operational current                     | I <sub>e</sub>    | A               | 12   |
| Contacts                                      |                   | Quantity        | 3  |
| 240 V   |                   |                 |  |
| Rated operational current                     | I <sub>e</sub>    | A               | 5  |
| Contacts                                      |                   | Quantity        | 5  |
| <b>DC-13, Control switches L/R = 50 ms</b>    |                   |                 |  |
| Rated operational current                     | I <sub>e</sub>    | A               | 20   |
| Voltage per contact pair in series            |                   | V               | 24   |
| Control circuit reliability at 24 V DC, 10 mA | Fault probability | H <sub>F</sub>  | < 10 <sup>-5</sup> , < 1 failure in 100,000 switching operations |
| <b>Terminal capacities</b>                    |                   |                 |  |
| Solid or stranded                             |                   | mm <sup>2</sup> | 1 x (1 - 6)<br>2 x (1 - 6)                                       |
| Flexible with ferrules to DIN 46228           |                   | mm <sup>2</sup> | 1 x (0.75 - 4)<br>2 x (0.75 - 4)                                 |
| Terminal screw                                |                   |                 | M4   |
| Tightening torque for terminal screw          |                   | Nm              | 1.6  |
| <b>Technical safety parameters:</b>           |                   |                 |  |
| <b>Notes</b>                                  |                   |                 |  |
|   |                   |                 | B10 <sub>d</sub> values as per EN ISO 13849-1, table C1          |

## Rating data for approved types

|  |       |       |             |
|--|-------|-------|-------------|
| Contacts                                 |       |       |             |
| Rated operational voltage                | $U_e$ | V AC  | 600         |
| Rated uninterrupted current max.         |       |       |             |
| Main conducting paths                    |       |       |             |
| General use                              |       | A     | 25          |
| Auxiliary contacts                       |       |       |             |
| General Use                              | $I_U$ | A     | 10          |
| Pilot Duty                               |       |       | A 600       |
| Switching capacity                       |       |       |             |
| Maximum motor rating                     |       |       |             |
| Single-phase                             |       |       |             |
| 120 V AC                                 |       | HP    | 1.5         |
| 200 V AC                                 |       | HP    | 3           |
| 240 V AC                                 |       | HP    | 3           |
| Three-phase                              |       |       |             |
| 200 V AC                                 |       | HP    | 3           |
| 240 V AC                                 |       | HP    | 3           |
| 480 V AC                                 |       | HP    | 7.5         |
| 600 V AC                                 |       | HP    | 10          |
| Short Circuit Current Rating             |       | SCCR  |             |
| Basic Rating                             |       | kA    | 5           |
| max. Fuse                                |       | A     | 40          |
| High fault rating                        |       | kA    | 10          |
| max. Fuse                                |       | A     | 40, Class J |
| Terminal capacity                        |       |       |             |
| Solid or flexible conductor with ferrule |       | AWG   | 14 - 10     |
| Terminal screw                           |       |       | M4          |
| Tightening torque                        |       | lb-in | 17.7        |

## Design verification as per IEC/EN 61439

|  |            |    |  |
|--|------------|----|--|
| Technical data for design verification   |            |    |  |
| Rated operational current for specified heat dissipation   | $I_n$      | A  | 32   |
| Heat dissipation per pole, current-dependent   | $P_{vid}$  | W  | 1.1  |
| Equipment heat dissipation, current-dependent  | $P_{vid}$  | W  | 0  |
| Static heat dissipation, non-current-dependent   | $P_{vs}$   | W  | 0  |
| Heat dissipation capacity  | $P_{diss}$ | W  | 0  |
| Operating ambient temperature min.   |            | °C | -25  |
| Operating ambient temperature max.   |            | °C | 40   |
| IEC/EN 61439 design verification   |            |    |  |
| 10.2 Strength of materials and parts   |            |    |  |
| 10.2.2 Corrosion resistance  |            |    | Meets the product standard's requirements.                         |
| 10.2.3.1 Verification of thermal stability of enclosures   |            |    |  |
| 10.2.3.2 Verification of resistance of insulating materials to normal heat   |            |    | Meets the product standard's requirements.                         |
| 10.2.3.3 Verification of resistance of insulating materials to abnormal heat and fire due to internal electric effects |            |    | Meets the product standard's requirements.                         |
| 10.2.4 Resistance to ultra-violet (UV) radiation   |            |    | UV resistance only in connection with protective shield.           |
| 10.2.5 Lifting   |            |    | Does not apply, since the entire switchgear needs to be evaluated. |
| 10.2.6 Mechanical impact   |            |    | Does not apply, since the entire switchgear needs to be evaluated. |
| 10.2.7 Inscriptions  |            |    | Meets the product standard's requirements.                         |
| 10.3 Degree of protection of ASSEMBLIES  |            |    | Does not apply, since the entire switchgear needs to be evaluated. |
| 10.4 Clearances and creepage distances   |            |    | Meets the product standard's requirements.                         |
| 10.5 Protection against electric shock   |            |    | Does not apply, since the entire switchgear needs to be evaluated. |
| 10.6 Incorporation of switching devices and components   |            |    | Does not apply, since the entire switchgear needs to be evaluated. |
| 10.7 Internal electrical circuits and connections  |            |    | Is the panel builder's responsibility.                             |

|  |  |  |
|--|--|--|
| 10.8 Connections for external conductors                 |  | Is the panel builder's responsibility.   |
| 10.9 Insulation properties                               |  |  |
| 10.9.2 Power-frequency electric strength                 |  | Is the panel builder's responsibility.   |
| 10.9.3 Impulse withstand voltage                         |  | Is the panel builder's responsibility.   |
| 10.9.4 Testing of enclosures made of insulating material |  | Is the panel builder's responsibility.   |
| 10.10 Temperature rise                                   |  | The panel builder is responsible for the temperature rise calculation. Eaton will provide heat dissipation data for the devices. |
| 10.11 Short-circuit rating                               |  | Is the panel builder's responsibility. The specifications for the switchgear must be observed.                                   |
| 10.12 Electromagnetic compatibility                      |  | Is the panel builder's responsibility. The specifications for the switchgear must be observed.                                   |
| 10.13 Mechanical function                                |  | The device meets the requirements, provided the information in the instruction leaflet (IL) is observed.                         |

## Technical data ETIM 7.0

|   |    |                            |
|---|----|----------------------------|
| Low-voltage industrial components (EG000017) / Switch disconnecter (EC000216)   |    |                            |
| Electric engineering, automation, process control engineering / Low-voltage switch technology / Off-load switch, circuit breaker, control switch / Switch disconnecter (ecl@ss10.0.1-27-37-14-03 [AKF060013]) |    |                            |
| Version as main switch  |    | Yes                        |
| Version as maintenance-/service switch  |    | Yes                        |
| Version as safety switch  |    | No                         |
| Version as emergency stop installation  |    | Yes                        |
| Version as reversing switch   |    | No                         |
| Number of switches  |    | 1                          |
| Max. rated operation voltage U <sub>e</sub> AC  | V  | 690                        |
| Rated operating voltage   | V  | 690 - 690                  |
| Rated permanent current I <sub>u</sub>  | A  | 32                         |
| Rated permanent current at AC-23, 400 V   | A  | 32                         |
| Rated permanent current at AC-21, 400 V   | A  | 32                         |
| Rated operation power at AC-3, 400 V  | kW | 11                         |
| Rated short-time withstand current I <sub>cw</sub>  | kA | 0.65                       |
| Rated operation power at AC-23, 400 V   | kW | 15                         |
| Switching power at 400 V  | kW | 15                         |
| Conditioned rated short-circuit current I <sub>q</sub>  | kA | 1                          |
| Number of poles   |    | 3                          |
| Number of auxiliary contacts as normally closed contact   |    | 1                          |
| Number of auxiliary contacts as normally open contact   |    | 2                          |
| Number of auxiliary contacts as change-over contact   |    | 0                          |
| Motor drive optional  |    | No                         |
| Motor drive integrated  |    | No                         |
| Voltage release optional  |    | No                         |
| Device construction   |    | Complete device in housing |
| Suitable for ground mounting  |    | Yes                        |
| Suitable for front mounting 4-hole  |    | No                         |
| Suitable for front mounting centre  |    | No                         |
| Suitable for distribution board installation  |    | No                         |
| Suitable for intermediate mounting  |    | No                         |
| Colour control element  |    | Red                        |
| Type of control element   |    | Door coupling rotary drive |
| Interlockable   |    | Yes                        |
| Type of electrical connection of main circuit   |    | Screw connection           |
| Degree of protection (IP), front side   |    | IP65                       |
| Degree of protection (NEMA)   |    | 12                         |

## Approvals

|                   |  |  |
|-------------------|--|--|
| Product Standards |  | UL 60947-4-1; CSA - C22.2 No. 60947-4-1-14; CSA-C22.2 No. 94; IEC/EN 60947-3; CE marking |
| UL File No.       |  | E36332   |

|                                      |  |  |
|--------------------------------------|--|--|
| UL Category Control No.              |  | NLRV   |
| CSA File No.                         |  | 12528  |
| CSA Class No.                        |  | 3211-07  |
| North America Certification          |  | UL listed, CSA certified                                       |
| Specially designed for North America |  | Yes, with additional labeling according to UL on the enclosure |
| Suitable for                         |  | Branch circuits, suitable as motor disconnect                  |
| Degree of Protection                 |  | IEC: IP65; UL/CSA Type 1, 12                                   |

## Dimensions

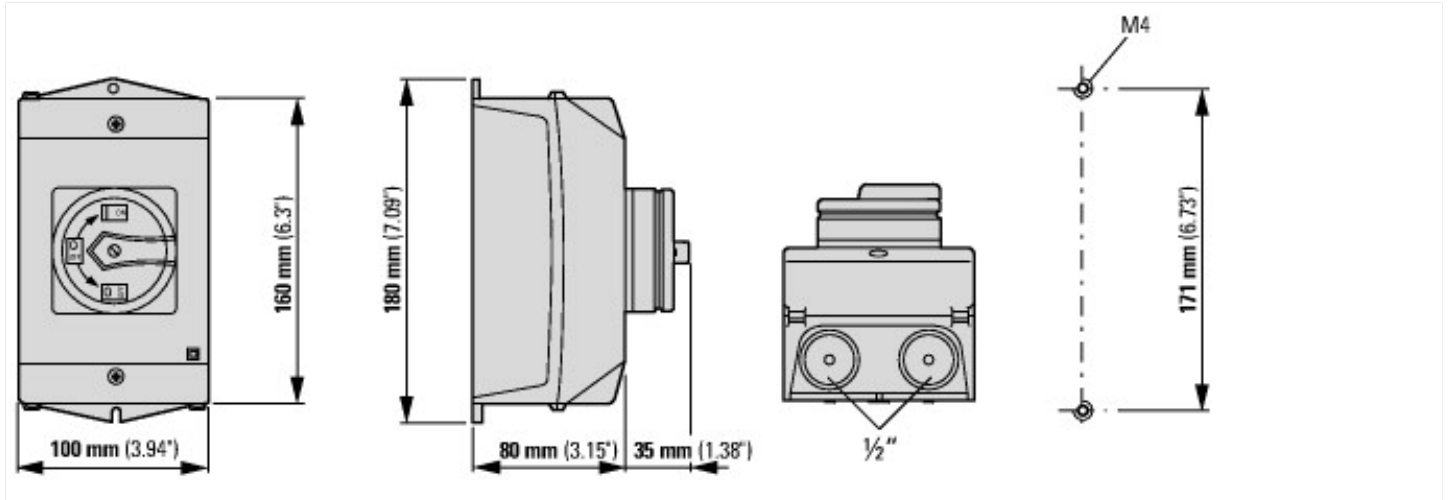

M4

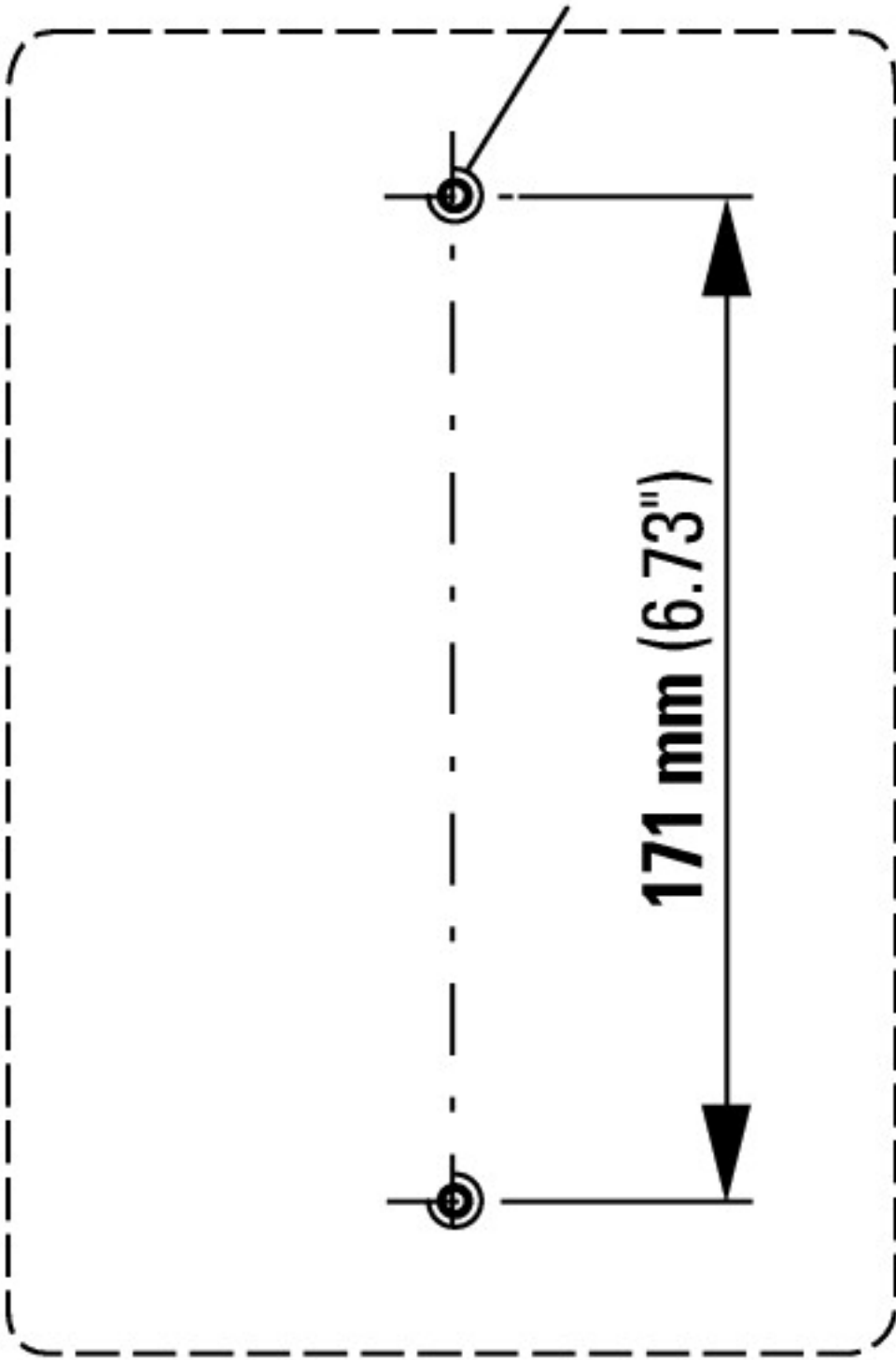

Drilling dimensions base

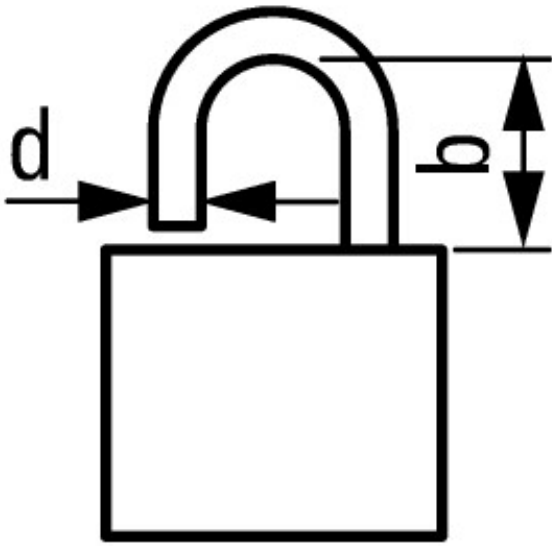

$$d = 4 - 8 \text{ mm}$$

$$b + d \leq 47 \text{ mm}$$

$$d = 0.16 - 0.31''$$

$$b + d \leq 1.85''$$

≤ 3 padlocks

### Additional product information (links)

IL03801014Z (AWA1150-2327) Cam switches NA: Circuit Diagrams | IL03801011Z\*.pdf; IL03801011Z (AWA1150-2005) Cam switches: surface mounting enclosure

|  |   |
|--|---|
| IL03801014Z (AWA1150-2327) Cam switches NA: Circuit Diagrams   IL03801011Z*.pdf; IL03801011Z (AWA1150-2005) Cam switches: surface mounting enclosure | <a href="ftp://ftp.moeller.net/DOCUMENTATION/AWA_INSTRUCTIONS/IL03801014Z2018_05.pdf">ftp://ftp.moeller.net/DOCUMENTATION/AWA_INSTRUCTIONS/IL03801014Z2018_05.pdf</a>                           |
| Display flip catalog page.   | <a href="http://ecat.moeller.net/flip-cat/?edition=K115A&amp;startpage=40">http://ecat.moeller.net/flip-cat/?edition=K115A&amp;startpage=40</a>   |
| Technical overview cam switch, switch-disconnector   | <a href="http://de.ecat.moeller.net/flip-cat/?edition=HPLTEv1&amp;startpage=4.2">http://de.ecat.moeller.net/flip-cat/?edition=HPLTEv1&amp;startpage=4.2</a>                                     |
| System overview cam switch T   | <a href="http://de.ecat.moeller.net/flip-cat/?edition=HPLTEv1&amp;startpage=4.4">http://de.ecat.moeller.net/flip-cat/?edition=HPLTEv1&amp;startpage=4.4</a>                                     |
| System overview switch-disconnector P  | <a href="http://de.ecat.moeller.net/flip-cat/?edition=HPLTEv1&amp;startpage=4.6">http://de.ecat.moeller.net/flip-cat/?edition=HPLTEv1&amp;startpage=4.6</a>                                     |
| Key to part numbers Cam switch   | <a href="http://de.ecat.moeller.net/flip-cat/?edition=HPLTEv1&amp;startpage=4.8">http://de.ecat.moeller.net/flip-cat/?edition=HPLTEv1&amp;startpage=4.8</a>                                     |
| Key to part numbers Switch-disconnector  | <a href="http://de.ecat.moeller.net/flip-cat/?edition=HPLTEv1&amp;startpage=4.8">http://de.ecat.moeller.net/flip-cat/?edition=HPLTEv1&amp;startpage=4.8</a>                                     |
| Switches for ATEX  | <a href="http://www.coopercrouse-hinds.eu/en/products/25-ex-safety-and-main-current-switches.html">http://www.coopercrouse-hinds.eu/en/products/25-ex-safety-and-main-current-switches.html</a> |
| Ordering form for SOND switches and SOND front plates(DE_EN)   | <a href="ftp://ftp.moeller.net/DOCUMENTATION/PDF/MZ008005ZU_Orderform_Customized_Switch.pdf">ftp://ftp.moeller.net/DOCUMENTATION/PDF/MZ008005ZU_Orderform_Customized_Switch.pdf</a>             |
| Ordering form for SOND switches and SOND front plates(DE_EN)   | <a href="ftp://ftp.moeller.net/DOCUMENTATION/PDF/MZ008006ZU_Orderform_Customized_Switch.pdf">ftp://ftp.moeller.net/DOCUMENTATION/PDF/MZ008006ZU_Orderform_Customized_Switch.pdf</a>             |