



Main switch, +steel enclosure, 3p, 25A, handle black, lockable

**Part no.
Catalog No.**

**P1-25/ST/SVB-SW
201714**

Similar to illustration

Dimensions

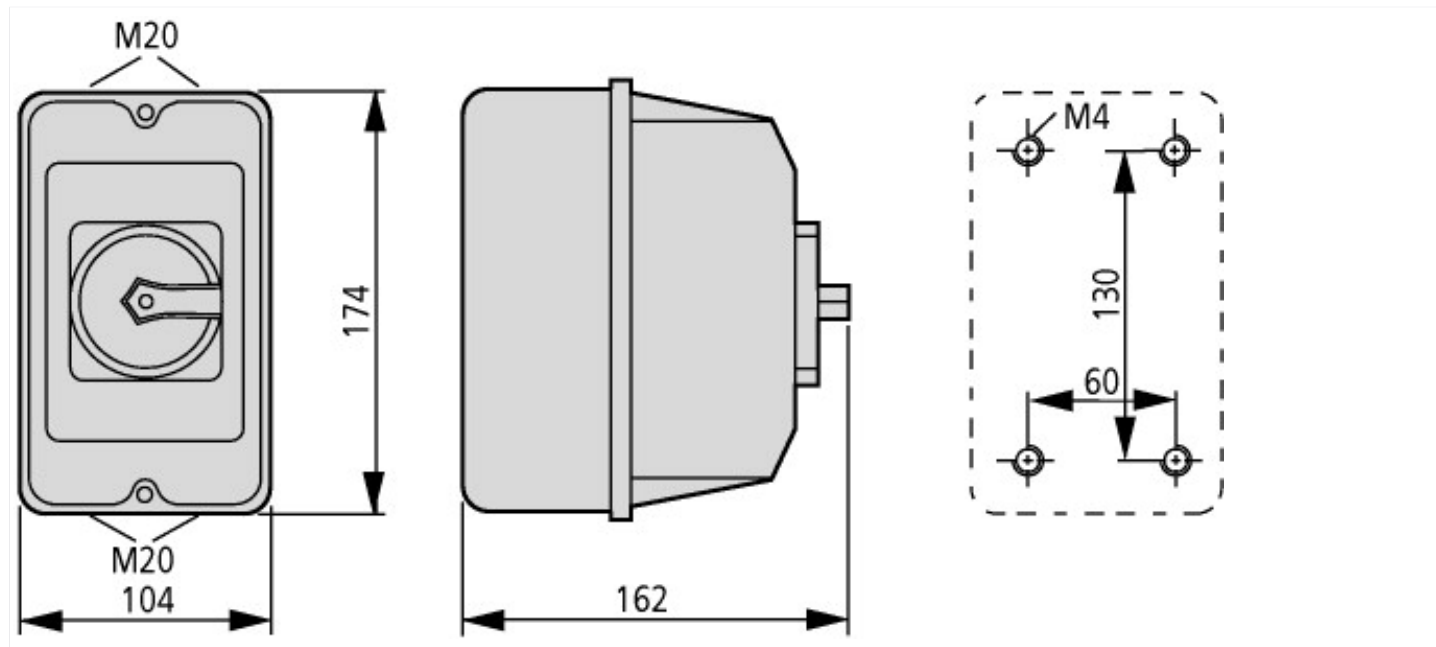

Assets (links)

Declaration of CE Conformity

00003102

Instruction Leaflets

IL03802007Z2018_05