



Variable frequency drive, 230 V AC, 1-phase, 4.3 A, 0.75 kW, IP20/NEMA 0, Radio interference suppression filter, FS1



Part no. **DB1-124D3FN-N2CC**
 Catalog No. **197194**

Delivery program

Product range			Variable frequency drives
Part group reference (e.g. DIL)			DB1
Rated operational voltage	U_e		230 V AC, 1-phase 240 V AC, single-phase
Output voltage with V_e	U_2		230 V AC, 3-phase 240 V AC, 3-phase
Mains voltage (50/60Hz)	U_{LN}	V	200 (-10%) - 240 (+10%)
Rated operational current			
At 150% overload	I_e	A	4.3
Note			Rated operational current at an operating frequency of 8 kHz and an ambient air temperature of +60°C depending on cooling
Assigned motor rating			
Note			for normal internally and externally ventilated 4 pole, three-phase asynchronous motors with 1500 rpm^{-1} at 50 Hz or 1800 min^{-1} at 60 Hz
Note			Overload cycle for 60 s every 600 s
Note			at 230 V, 50 Hz
150 % Overload	P	kW	0.75
150 % Overload	I_M	A	4.3
Note			at 220 - 240 V, 60 Hz
150 % Overload	P	HP	1
150 % Overload	I_M	A	4.3
Degree of Protection			IP20/NEMA 0
Interface/field bus (built-in)			OP-Bus (RS485)/Modbus RTU, CANopen®
Fitted with			Radio interference suppression filter Additional PCB protection
Parameterization			Keypad Feldbus drivesConnect drivesConnect mobile (App)
Frame size			FS1
Connection to SmartWire-DT			no

Technical data

General

Standards			General requirements: IEC/EN 61800-2 EMV - Requirements IEC/EN 61800-3 Safety Requirements: IEC/EN 61800-5-1
Certifications			CE, UL, cUL, RCM
Production quality			RoHS, ISO 9001
Climatic proofing	ρ_w	%	< 95%, average relative humidity (RH), non-condensing, non-corrosive
Ambient temperature			
Operating ambient temperature min.		°C	-10
Operating ambient temperature max.		°C	+ 60
			operation (with 150 % overload)
Storage	θ	°C	-40 - +60
Radio interference level			
Radio interference class (EMC)			C1 (for conducted emissions only), C2, C3, depending on the motor cable length, the connected load, and ambient conditions. External radio interference suppression filters (optional) may be necessary.
Environment (EMC)			1st and 2nd environments as per EN 61800-3

maximum motor cable length	l	m	C1 ≤ 1 m C2 ≤ 3 m C3 ≤ 10 m
Mechanical shock resistance		g	15 (11 m/s, EN 60068-2-27)
Vibration			EN 61800-5-1
Mounting position			As required depending on the cooling
Altitude		m	0 - 1000 m above sea level Above 1000 m: 1% derating for every 100 m max. 2000 m
Degree of Protection			IP20/NEMA 0
Protection against direct contact			BGV A3 (VBG4, finger- and back-of-hand proof)

Main circuit

Supply			
Rated operational voltage	U_e		230 V AC, 1-phase 240 V AC, single-phase
Mains voltage (50/60Hz)	U_{LN}	V	200 (-10%) - 240 (+10%)
Input current (150% overload)	I_{LN}	A	7.5
System configuration			AC supply systems with earthed center point
Supply frequency	f_{LN}	Hz	50/60
Frequency range	f_{LN}	Hz	48 - 62
Mains switch-on frequency			Maximum of one time every 30 seconds
Power section			
Function			Variable frequency drive with internal DC link and IGBT inverter
Overload current (150% overload)	I_L	A	6.45
max. starting current (High Overload)	I_H	%	175
Note about max. starting current			for 3.75 seconds every 600 seconds
Output voltage with V_e	U_2		230 V AC, 3-phase 240 V AC, 3-phase
Output Frequency	f_2	Hz	0 - 50/60 (max. 500)
Switching frequency	f_{PWM}	kHz	8 adjustable 4 - 32 (audible)
Operation Mode			U/f control Speed control with slip compensation
Frequency resolution (setpoint value)	Δf	Hz	0.1
Rated operational current			
At 150% overload	I_e	A	4.3
Note			Rated operational current at an operating frequency of 8 kHz and an ambient air temperature of +60°C depending on cooling
Power loss			
Heat dissipation at rated operational current $I_e = 150\%$	P_V	W	60
Efficiency	η	%	96
Maximum leakage current to ground (PE) without motor	I_{PE}	mA	3.5 (230 V)
Fitted with			Radio interference suppression filter Additional PCB protection
Frame size			FS1
Motor feeder			
Note			for normal internally and externally ventilated 4 pole, three-phase asynchronous motors with 1500 rpm^{-1} at 50 Hz or 1800 min^{-1} at 60 Hz
Note			Overload cycle for 60 s every 600 s
Note			at 230 V, 50 Hz
150 % Overload	P	kW	0.75
Note			at 220 - 240 V, 60 Hz
150 % Overload	P	HP	1
maximum permissible cable length	l	m	screened: 10
Apparent power			
Apparent power at rated operation 230 V	S	kVA	0.99
Apparent power at rated operation 240 V	S	kVA	1.03
Braking function			

Standard braking torque			max. 30 % MN
DC braking torque			max. 100% of rated operational current I_b , variable

Control section

External control voltage	U_c	V	24 V DC (max. 100 mA)
Reference voltage	U_s	V	10 V DC (max. 10 mA)
Analog inputs			2, parameterizable, 0 - 10 V DC, 0/4 - 20 mA
Analog outputs			1, parameterizable, 0 - 10 V
Digital inputs			4, parameterizable, max. 30 V DC
Digital outputs			1, parameterizable, 24 V DC
Relay outputs			1, parameterizable, N/O, 6 A (250 V, AC-1) / 5 A (30 V, DC-1)
Interface/field bus (built-in)			OP-Bus (RS485)/Modbus RTU, CANopen®
Expansion slots			1

Assigned switching and protective elements

Power Wiring			
Safety device (fuse or miniature circuit-breaker)			
IEC (Type B, gG), 150 %			FAZ-B10/1N
UL (Class CC or J)		A	10
Mains contactor			
150 % overload (CT/ I_H , at 50 °C)			DILEM-...+P1DILEM
110 % overload (VT/ I_L , at 40 °C)			DILM7-... + DILM12-XP1
Main choke			
150 % overload (CT/ I_H , at 50 °C)			DX-LN1-009
Motor feeder			
motor choke			
150 % overload (CT/ I_H , at 50 °C)			DX-LM3-005
Sine filter			
150 % overload (CT/ I_H , at 50 °C)			DX-SIN3-010

Design verification as per IEC/EN 61439

Technical data for design verification			
Rated operational current for specified heat dissipation	I_n	A	4.3
Heat dissipation per pole, current-dependent	P_{vid}	W	0
Equipment heat dissipation, current-dependent	P_{vid}	W	60
Static heat dissipation, non-current-dependent	P_{vs}	W	0
Heat dissipation capacity	P_{diss}	W	0
Operating ambient temperature min.		°C	-10
Operating ambient temperature max.		°C	60
IEC/EN 61439 design verification			
10.2 Strength of materials and parts			
10.2.2 Corrosion resistance			Meets the product standard's requirements.
10.2.3.1 Verification of thermal stability of enclosures			Meets the product standard's requirements.
10.2.3.2 Verification of resistance of insulating materials to normal heat			Meets the product standard's requirements.
10.2.3.3 Verification of resistance of insulating materials to abnormal heat and fire due to internal electric effects			Meets the product standard's requirements.
10.2.4 Resistance to ultra-violet (UV) radiation			Meets the product standard's requirements.
10.2.5 Lifting			Does not apply, since the entire switchgear needs to be evaluated.
10.2.6 Mechanical impact			Does not apply, since the entire switchgear needs to be evaluated.
10.2.7 Inscriptions			Meets the product standard's requirements.
10.3 Degree of protection of ASSEMBLIES			Does not apply, since the entire switchgear needs to be evaluated.
10.4 Clearances and creepage distances			Meets the product standard's requirements.
10.5 Protection against electric shock			Does not apply, since the entire switchgear needs to be evaluated.
10.6 Incorporation of switching devices and components			Does not apply, since the entire switchgear needs to be evaluated.
10.7 Internal electrical circuits and connections			Is the panel builder's responsibility.
10.8 Connections for external conductors			Is the panel builder's responsibility.
10.9 Insulation properties			

10.9.2 Power-frequency electric strength		Is the panel builder's responsibility.
10.9.3 Impulse withstand voltage		Is the panel builder's responsibility.
10.9.4 Testing of enclosures made of insulating material		Is the panel builder's responsibility.
10.10 Temperature rise		The panel builder is responsible for the temperature rise calculation. Eaton will provide heat dissipation data for the devices.
10.11 Short-circuit rating		Is the panel builder's responsibility. The specifications for the switchgear must be observed.
10.12 Electromagnetic compatibility		Is the panel builder's responsibility. The specifications for the switchgear must be observed.
10.13 Mechanical function		The device meets the requirements, provided the information in the instruction leaflet (IL) is observed.

Technical data ETIM 7.0

Low-voltage industrial components (EG000017) / Frequency converter =< 1 kV (EC001857)			
Electric engineering, automation, process control engineering / Electrical drive / Static frequency converter / Static frequency converter = < 1 kV (ecl@ss10.0.1-27-02-31-01 [AKE177014])			
Mains voltage	V		200 - 240
Mains frequency			50/60 Hz
Number of phases input			1
Number of phases output			3
Max. output frequency	Hz		500
Max. output voltage	V		250
Nominal output current I2N	A		4.3
Max. output at quadratic load at rated output voltage	kW		0.75
Max. output at linear load at rated output voltage	kW		0.75
Relative symmetric net frequency tolerance	%		10
Relative symmetric net voltage tolerance	%		10
Number of analogue outputs			1
Number of analogue inputs			2
Number of digital outputs			1
Number of digital inputs			4
With control unit			No
Application in industrial area permitted			Yes
Application in domestic- and commercial area permitted			Yes
Supporting protocol for TCP/IP			No
Supporting protocol for PROFIBUS			No
Supporting protocol for CAN			Yes
Supporting protocol for INTERBUS			No
Supporting protocol for ASI			No
Supporting protocol for KNX			No
Supporting protocol for MODBUS			Yes
Supporting protocol for Data-Highway			No
Supporting protocol for DeviceNet			No
Supporting protocol for SUCONET			No
Supporting protocol for LON			No
Supporting protocol for PROFINET IO			No
Supporting protocol for PROFINET CBA			No
Supporting protocol for SERCOS			No
Supporting protocol for Foundation Fieldbus			No
Supporting protocol for EtherNet/IP			No
Supporting protocol for AS-Interface Safety at Work			No
Supporting protocol for DeviceNet Safety			No
Supporting protocol for INTERBUS-Safety			No
Supporting protocol for PROFIsafe			No
Supporting protocol for SafetyBUS p			No
Supporting protocol for BACnet			No
Supporting protocol for other bus systems			Yes
Number of HW-interfaces industrial Ethernet			0

Number of interfaces PROFINET		0
Number of HW-interfaces RS-232		0
Number of HW-interfaces RS-422		0
Number of HW-interfaces RS-485		1
Number of HW-interfaces serial TTY		0
Number of HW-interfaces USB		0
Number of HW-interfaces parallel		0
Number of HW-interfaces other		0
With optical interface		No
With PC connection		Yes
Integrated breaking resistance		No
4-quadrant operation possible		No
Type of converter		U converter
Degree of protection (IP)		IP20
Degree of protection (NEMA)		Other
Height	mm	130
Width	mm	118
Depth	mm	74

Approvals

Product Standards		UL 508C; CSA-C22.2 No. 14; IEC/EN61800-3; IEC/EN61800-5; CE marking
UL File No.		E172143
UL Category Control No.		NMMS, NMMS7
CSA File No.		UL report applies to both US and Canada
North America Certification		UL listed, certified by UL for use in Canada
Specially designed for North America		No
Suitable for		Branch circuits
Max. Voltage Rating		1~ 240 V AC IEC: TN-S UL/CSA: "Y" (Solidly Grounded Wey)
Degree of Protection		IEC: IP20

Dimensions

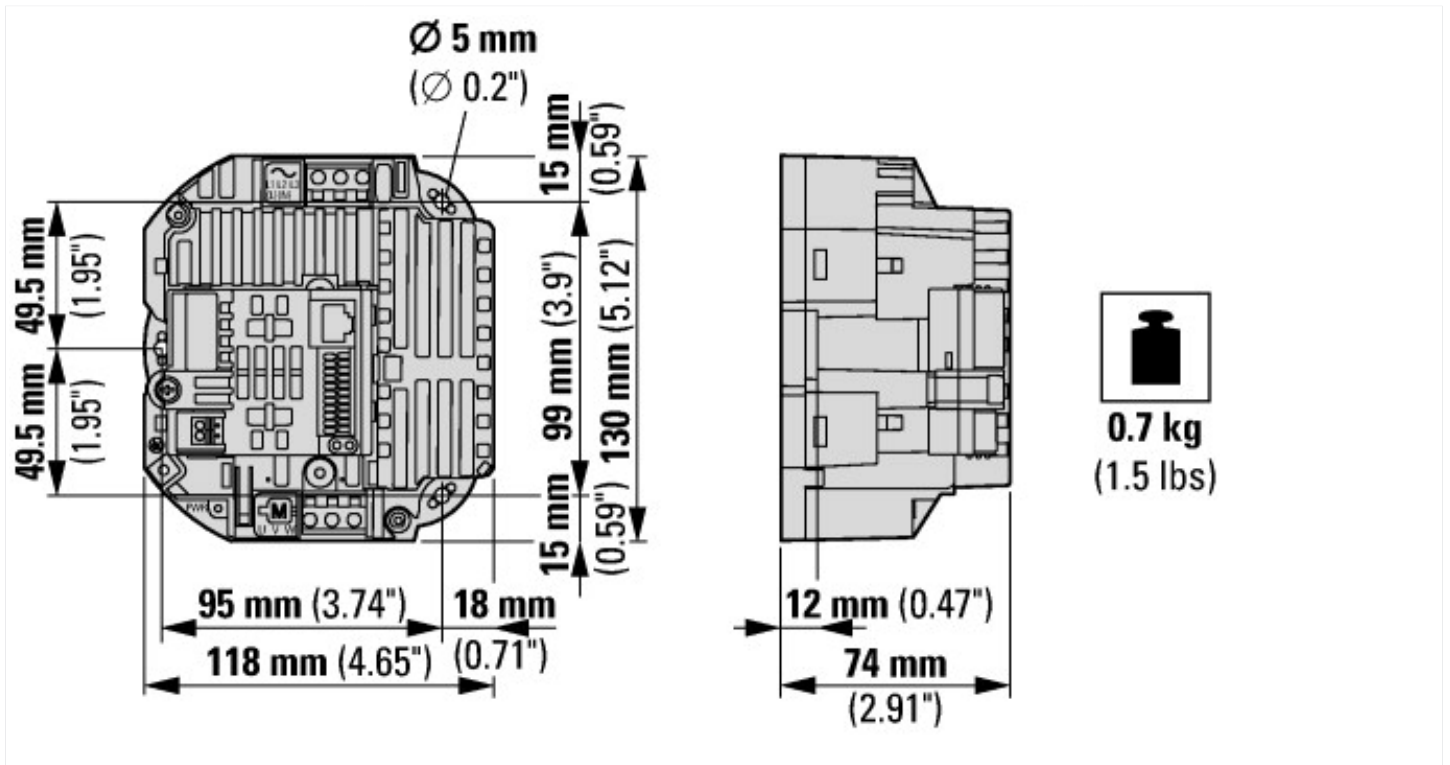

Assets (links)

Declaration of CE Conformity

00003112

Additional product information (links)

IL040044ZU DB1 Frequency inverter

IL040044ZU DB1 Frequency inverter	ftp://ftp.moeller.net/DOCUMENTATION/AWA_INSTRUCTIONS/IL040044ZU2020_02.pdf
-----------------------------------	---

MN040031 DB1 variable frequency drives, Installation manual

MN040031 Frequenzumrichter DB1, Installationshandbuch - Deutsch	ftp://ftp.moeller.net/DOCUMENTATION/AWB_MANUALS/MN040031_DE.pdf
---	---

MN040031 DB1 variable frequency drives, Installation manual - English	ftp://ftp.moeller.net/DOCUMENTATION/AWB_MANUALS/MN040031_EN.pdf
---	---

MN040034 DB1 DB1 variable frequency drives, Parameters manual

MN040034 Frequenzumrichter DB1, Parameterhandbuch - Deutsch	ftp://ftp.moeller.net/DOCUMENTATION/AWB_MANUALS/MN040034_DE.pdf
---	---

MN040034 DB1 DB1 variable frequency drives, Parameters manual - English	ftp://ftp.moeller.net/DOCUMENTATION/AWB_MANUALS/MN040034_EN.pdf
---	---