



SWD accessories, Local SmartWire-DT branch

Part no. EU2A-SWD-PBWN  
 Catalog No. 174734  
 Alternate Catalog No. EU2A-SWD-PBWN



Delivery program

Product range			SmartWire-DT accessories
Basic function			Cable adapters
Function			Local SmartWire-DT branch
Description			SWD branch for putting together a local SWD network with SWD module (IP67)
Connection to SmartWire-DT			yes

Technical data

General

Standards			IEC/EN 61131-2 EN50178 IEC/EN 60529
Dimensions (W x H x D)		mm	85.6 x 56.9 x 20.1
Weight		kg	0.11
Mounting			DIN-rail, screw fixing (M5), mounting section (Clip M20)
Mounting position			As required
Note on heat dissipation			not relevant

Ambient conditions, mechanical

Protection type (IEC/EN 60529, EN50178, VBG 4)			IP67
Vibrations (IEC/EN 61131-2:2008)			
Constant amplitude 3,5 mm		Hz	
constant amplitude 0.15 mm max.		Hz	8.4
constant amplitude 0.15 mm minim.		Hz	5
Constant acceleration 1 g		Hz	
constant acceleration 1 g max.		Hz	150
constant acceleration 1 g min.		Hz	8.4
Mechanical shock resistance (IEC/EN 60068-2-27) semi-sinusoidal 15 g/11 ms		Impacts	9
Drop to IEC/EN 60068-2-31	Drop height	mm	50
Free fall, packaged (IEC/EN 60068-2-32)		m	0.3

Electromagnetic compatibility (EMC)

Overvoltage category			II
Pollution degree			3
Electrostatic discharge (IEC/EN 61131-2:2008)			
Air discharge (Level 3)		kV	8
Contact discharge (Level 2)		kV	4
Electromagnetic fields (IEC/EN 61131-2:2008)			
2 - 2.7 GHz		V/m	1
1.4 - 2 GHz		V/m	3
80 - 1000 MHz		V/m	10
Radio interference suppression			Class A
Burst (IEC/EN 61131-2:2008, Level 3)			
SmartWire-DT cables		kV	1
Radiated RFI (IEC/EN 61131-2:2008, Level 3)		V	10

Climatic environmental conditions

Climatic proofing			Dry heat to IEC 60068-2-2 Damp heat as per EN 60068-2-3
Air pressure (operation)		hPa	795 - 1080
Ambient temperature			
Operation	θ	°C	-25 - +55

Storage / Transport	0	°C	-40 - +70
Relative humidity			
Condensation			permissible

### Connection options

Connection 1			M12 plug, A-keyed
Connection 2			M12 socket (A-keyed), 5-pin

### Design verification as per IEC/EN 61439

Technical data for design verification			
Static heat dissipation, non-current-dependent	P <sub>Vs</sub>	W	0
Heat dissipation capacity	P <sub>diss</sub>	W	0
Operating ambient temperature min.		°C	-25
Operating ambient temperature max.		°C	70
Degree of Protection			IP67
IEC/EN 61439 design verification			
10.2 Strength of materials and parts			
10.2.2 Corrosion resistance			Meets the product standard's requirements.
10.2.3.1 Verification of thermal stability of enclosures			Meets the product standard's requirements.
10.2.3.2 Verification of resistance of insulating materials to normal heat			Meets the product standard's requirements.
10.2.3.3 Verification of resistance of insulating materials to abnormal heat and fire due to internal electric effects			Meets the product standard's requirements.
10.2.4 Resistance to ultra-violet (UV) radiation			Meets the product standard's requirements.
10.2.5 Lifting			Does not apply, since the entire switchgear needs to be evaluated.
10.2.6 Mechanical impact			Does not apply, since the entire switchgear needs to be evaluated.
10.2.7 Inscriptions			Meets the product standard's requirements.
10.3 Degree of protection of ASSEMBLIES			Meets the product standard's requirements.
10.4 Clearances and creepage distances			Meets the product standard's requirements.
10.5 Protection against electric shock			Does not apply, since the entire switchgear needs to be evaluated.
10.6 Incorporation of switching devices and components			Does not apply, since the entire switchgear needs to be evaluated.
10.7 Internal electrical circuits and connections			Is the panel builder's responsibility.
10.8 Connections for external conductors			Is the panel builder's responsibility.
10.9 Insulation properties			
10.9.2 Power-frequency electric strength			Is the panel builder's responsibility.
10.9.3 Impulse withstand voltage			Is the panel builder's responsibility.
10.9.4 Testing of enclosures made of insulating material			Is the panel builder's responsibility.
10.10 Temperature rise			The panel builder is responsible for the temperature rise calculation. Eaton will provide heat dissipation data for the devices.
10.11 Short-circuit rating			Is the panel builder's responsibility.
10.12 Electromagnetic compatibility			Is the panel builder's responsibility.
10.13 Mechanical function			The device meets the requirements, provided the information in the instruction leaflet (IL) is observed.

### Technical data ETIM 7.0

PLC's (EG000024) / Accessories for controls (EC002584)			
Electric engineering, automation, process control engineering / Control / Programmable logic control (SPS) / Programmable logic control (SPS, accessories) (ecl@ss10.0.1-27-24-22-92 [AFR333003])			
Type of electrical accessory			Plug
Type of mechanical accessory			Other

## Dimensions

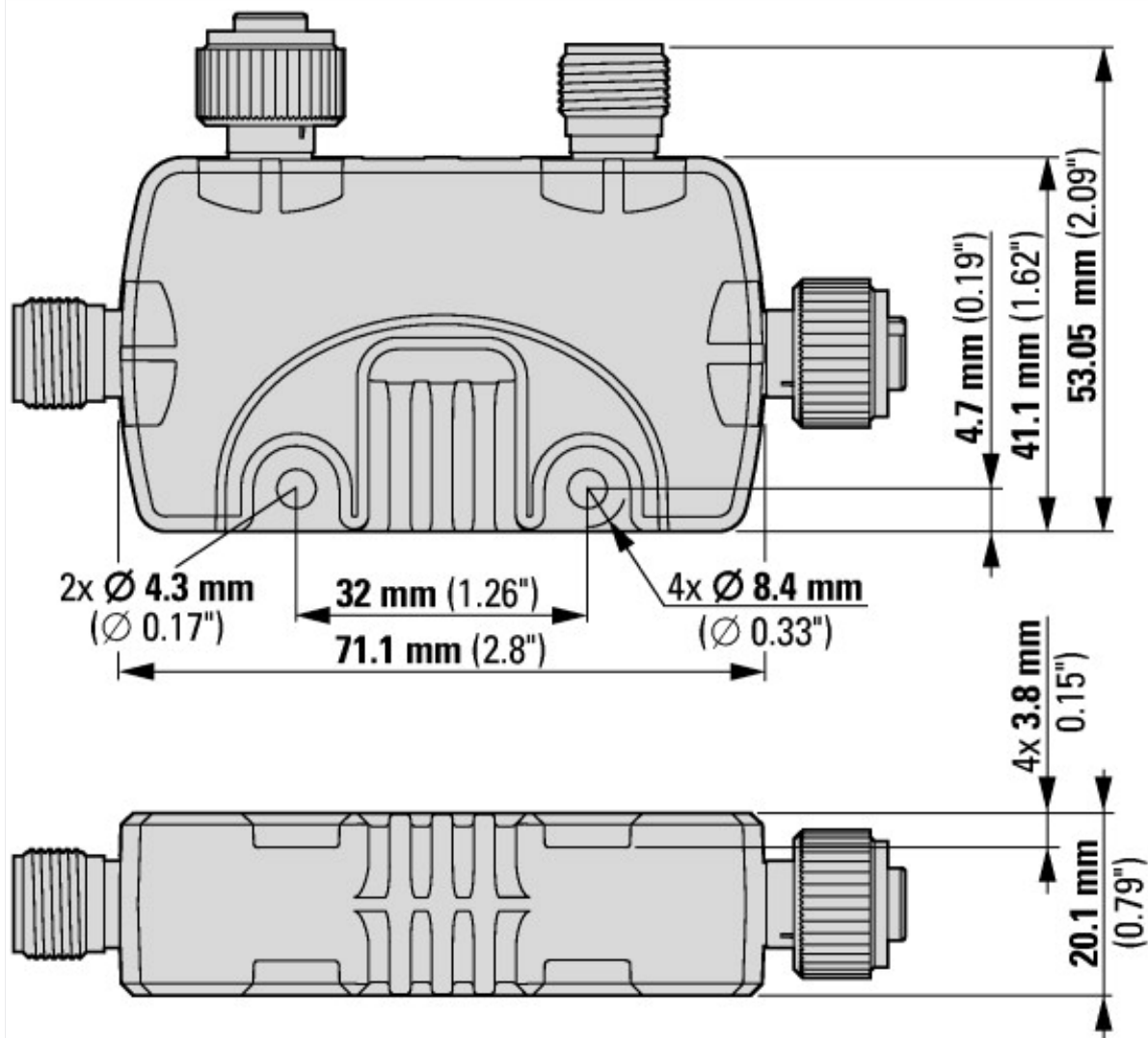

SWD junction, passive

## Additional product information (links)

SmartWire-DT product range catalog	<a href="http://ecat.moeller.net/flip-cat/?edition=SWKAT&amp;startpage=Titel">http://ecat.moeller.net/flip-cat/?edition=SWKAT&amp;startpage=Titel</a>
f1=1457&f2=1181&f3=1530;Download Wizard SWD-ASSIST	<a href="http://applications.eaton.eu/sdlc?LX=11&amp;f1=1457&amp;f2=1181&amp;f3=1530;Download Wizard SWD-ASSIST">http://applications.eaton.eu/sdlc?LX=11&amp;f1=1457&amp;f2=1181&amp;f3=1530;Download Wizard SWD-ASSIST</a>
Product overview (WEB)	<a href="http://www.eaton.eu/swd">http://www.eaton.eu/swd</a>