



Main switch, +steel enclosure, 3p, 100A, handle black, lockable

Part no. P3-100/ST/SVB-SW
 Catalog No. 201717

Technical data ETIM 4.0

Version as switch disconnecter compact		Yes
Version as main switch		Yes
Version as maintenance-/service switch		Yes
Version as safety switch		No
Version as emergency stop installation		No
Max. rated operation voltage Ue AC	V	690
Rated permanent current Iu	A	100
Rated operation power AC-3, 400 V	kW	37
Rated operation power at AC-23, 400V	kW	50
Conditioned rated short-circuit current Iq	kA	0
Number of poles		3
Number of auxiliary contacts as normally closed contact		0
Number of auxiliary contacts as normally open contact		0
Number of auxiliary contacts as change-over contact		0
Motor drive optional		No
Motor drive integrated		No
Voltage release optional		No
Device construction		Built-in device fixed built-in technique
Suitable for ground mounting		No
Suitable for front mounting		No
Suitable for front mounting center		No
Suitable for distribution board installation		No
Suitable for intermediate mounting		No
Type of control element		-
Interlockable		Yes
Connection type main current circuit		Screw connection
Degree of protection (IP), front side		IP65

Dimensions

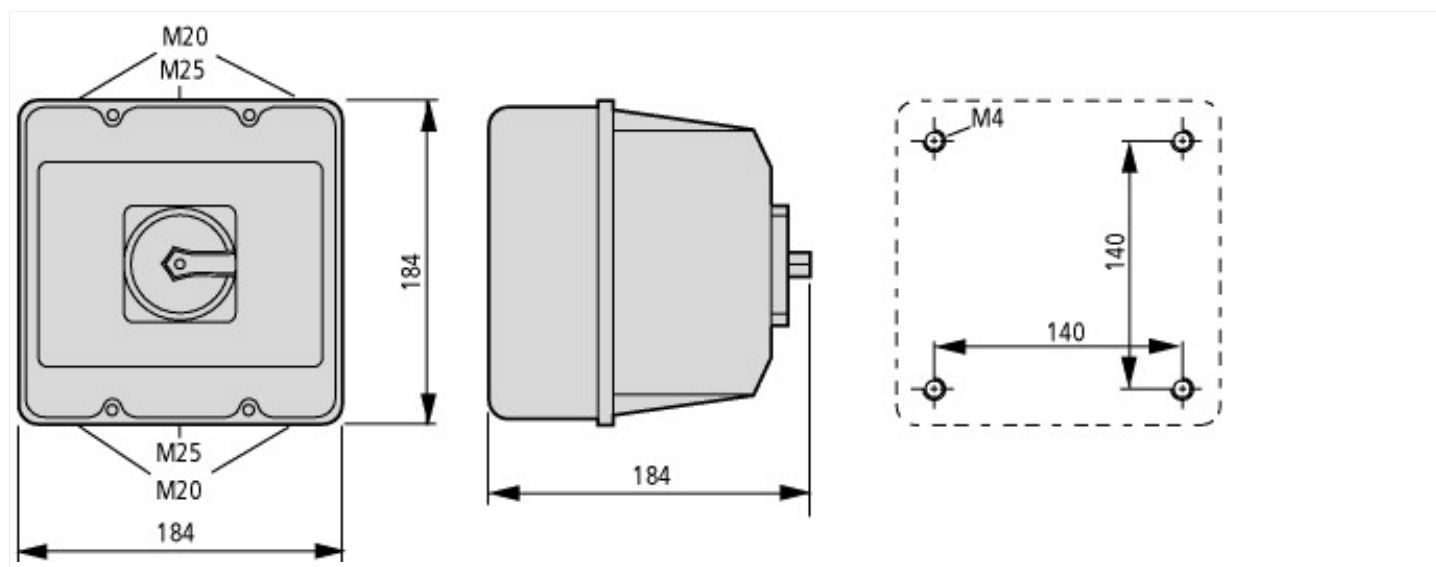

Assets (links)

Declaration of CE Conformity

00003104

Instruction Leaflets

IL03802007Z2018_05