



Proximity switch, inductive, 1N/O, Sn=8mm, 3L, 10-30VDC, PNP, M18, insulated material, line 2m

Part no. E55CAL18T111E
Catalog No. 135827
Alternate Catalog No. E55CAL18T111E

Delivery program

Basic function			Inductive Sensors
Product range			E55 Limit Switch Style Series
Connection			3-wire
Design (outer dimensions)		mm	M18 x 1
Rated operational voltage	U_e		10 - 30 V DC
Rated switching distance	S_n	mm	8
Type of mounting			Non-flush
Switching type			PNP
For connection of:			2 m connection cable
Contacts			
N/O = Normally open			1 N/O
Material			Insulated material
Degree of Protection			IP66

Technical data

General

Standards			IEC/EN 60947-5-2
Ambient temperature			-25 - +70
Mechanical shock resistance		g	30 Shock duration 11 ms
Degree of Protection			IP66

Characteristics

Rated switching distance			
Rated switching distance	S_n	mm	8
Repetition accuracy of S_n		%	10
Temperature drift of S_n		%	10
Switching hysteresis of S_n		%	20
Rated operational voltage	U_e		10 - 30 V DC
Supply frequency			50 - 60
Residual ripple of U_e		%	10
Maximum load current	I_e	mA	< 200
Operating current in the switched state at 24 V DC	I_b	mA	3
Voltage drop at I_e	U_d	V	8
Switching Frequency		Hz	500
Switching state display		LED	Red
Protective functions			Short-circuit protective device Protection against polarity reversal
Connection			3-wire
Contacts			
N/O = Normally open			1 N/O
Style			
Design (outer dimensions)		mm	M18 x 1
For connection of:			2 m connection cable
Material			Insulated material

Design verification as per IEC/EN 61439

Technical data for design verification		
Operating ambient temperature min.	°C	-25
Operating ambient temperature max.	°C	70

Technical data ETIM 7.0

Sensors (EG000026) / Inductive proximity switch (EC002714)		
Electric engineering, automation, process control engineering / Binary sensor technology, safety-related sensor technology / Proximity switch / Inductive proximity switch (ecl@ss10.0.1-27-27-01-01 [AGZ376015])		
Width sensor	mm	0
Height of sensor	mm	0
Length of sensor	mm	55
Diameter sensor	mm	18
Mechanical mounting condition for sensor		Not flat
Switching distance	mm	8
Suitable for safety functions		No
Type of switch function		Normally open contact
Type of switching output		PNP
Type of electric connection		Cable
Number of semiconductor outputs with signalling function		1
Number of contact energized outputs with signalling function		0
Number of protected semiconductor outputs		0
Number of protected contact energized outputs		0
Type of actuation		Metallic Target
Type of interface		None
Type of interface for safety communication		None
Construction type housing		Cylinder, screw-thread
Coating housing		Other
Cascadable		No
Category according to EN 954-1		B
SIL according to IEC 61508		None
Performance level acc. EN ISO 13849-1		None
Max. output current at protected output	mA	0
Supply voltage	V	10 - 30
Rated control supply voltage Us at AC 50HZ	V	0 - 0
Rated control supply voltage Us at AC 60HZ	V	0 - 0
Rated control supply voltage Us at DC	V	10 - 30
Voltage type		DC
Switching frequency	Hz	500
With monitoring function downstream switching devices		No
Material housing		Plastic
Compression-resistant		No
Explosion safety category for gas		None
Explosion safety category for dust		None
Interference resistance to magnetic fields		

Approvals

Product Standards		CE marking
Max. Voltage Rating		30 V DC
Degree of Protection		IEC: IP66; UL/CSA: NEMA 4, 4X, 13

Dimensions

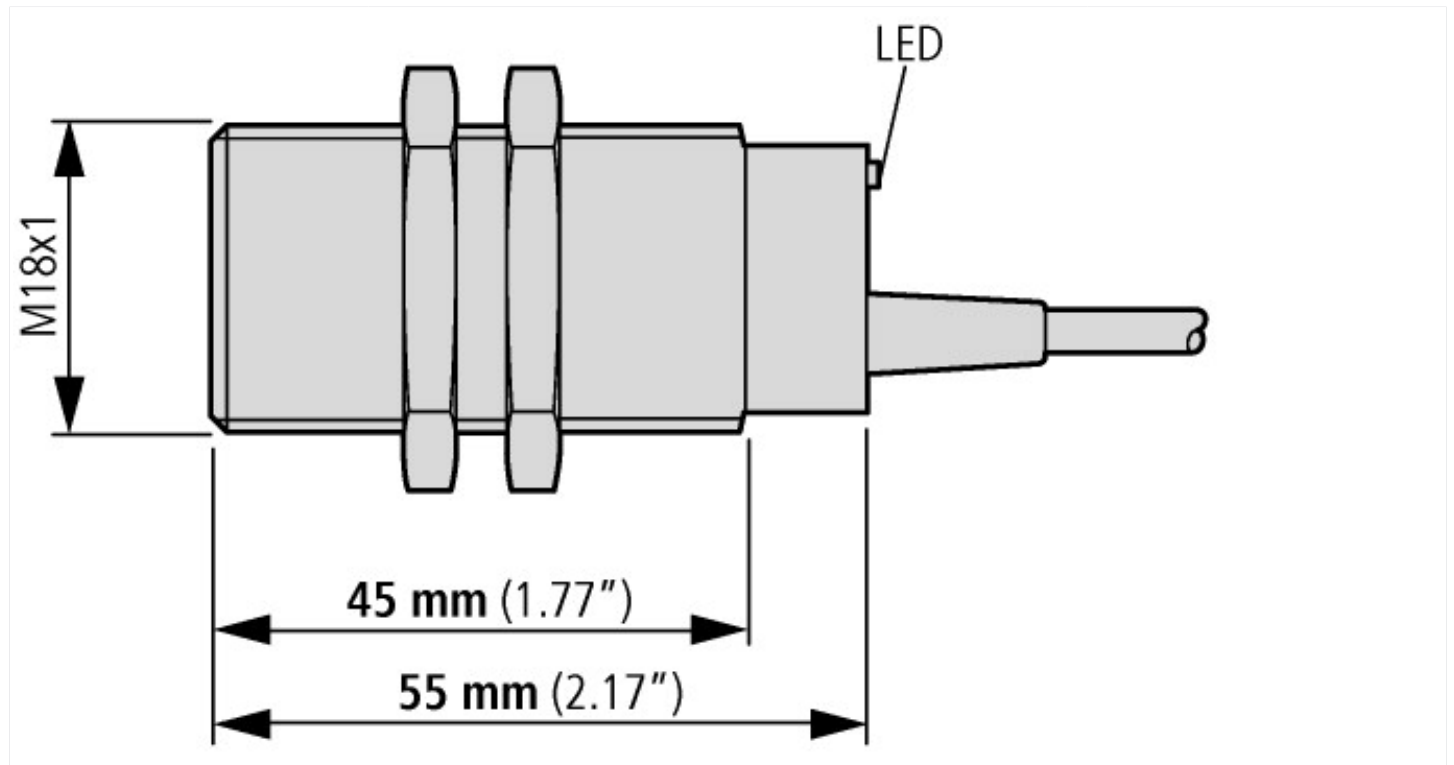

Assets (links)

Declaration of CE Conformity

00003158

Instruction Leaflets

IL05301005Z2018_05

Additional product information (links)

IL05301005Z E55 Series Barrel-Style Inductive Sensors

IL05301005Z E55 Series Barrel-Style Inductive Sensors ftp://ftp.moeller.net/DOCUMENTATION/AWA_INSTRUCTIONS/IL05301005Z2018_05.pdf