



Power supply module XI/ON, 120/230VAC

Part no. XN-PF-120/230VAC-D
Catalog No. 140072

EL-Nummer (Norway) 0004520655

Delivery program

Function			XI/ON power supply modules
Function			XN Slice module
Short Description			Field power supply module with 120/230 V AC nominal voltage
For use with			XN-P3T-SBB XN-P3S-SBB XN-P4T-SBBC XN-P4S-SBBC

Technical data

General

Standards			EN 61000-6-2 EN 61000-6-4 EN 61131-2
Potential isolation			Yes, through optocoupler
Ambient temperature		°C	0 - +55
Storage	θ	°C	-25 - +85
Relative humidity			5 - 95 % (indoor), Level RH-2, no condensation (for storage at 45°C)
Harmful gases		ppm	SO ₂ : 10 (rel. humidity < 75%, no condensation) H ₂ S: 1.0 (rel. humidity < 75 %,no condensation)
Vibration resistance, operating conditions			according to IEC/EN 60068-2-6
Mechanical shock resistance		g	according to IEC 60068-2-27
Continuous shock resistance (IEC/EN 60068-2-29)			According to IEC 60068-2-29
Drop and topple			According to IEC 60068-2-31, free fall according to IEC 60068-2-32
Degree of Protection			IP20
Electromagnetic compatibility (EMC)			
ESD	Air/contact discharge	kV	EN 61000-4-2
Electromagnetic fields	(0.08...1) / (1.4...2) / (2...2,7) GHz	V/m	EN 61100-4-2
Burst			EN 61100-4-4
Surge			EN 61100-4-5
Radiated RFI		V	EN 61100-4-6
Emitted interference (radiated, high frequency)	(30...230 MHz) / (230...1000 MHz)	dB	EN 55016-2-3
Voltage fluctuations/voltage dips			EN 61131-2
Type test			to EN 61131-2
Approvals			CE, cULus
Other technical data (sheet catalogue)			Technical Data

Supply modules

Coordination type "2"	U _{sys}	V DC	
Max. admissible range		V DC	4
Field voltage	U _L		120/230 V AC
Admissible range			102 - 132 V AC (120 V AC)

			195.5 - 253 V AC (230 V AC)
Rated current consumption from module bus	I_{MB}	mA	≤ 25
Rated insulation voltage	U_i	V AC	1500
Residual ripple		%	According to EN 61131-2; ripple < 5
Maximum operating current	I_{EI}	A	10
Number of diagnostic bytes			4
Base module without gateway power supply			
without C connection			2-/3-wire XN-P3x-SBB
with C connection			4-wire XN-P4x-SBBC
Power loss	P	W	1.3

Notes

Permissible range for nominal voltage and field voltage U_L :

to EN 61131-2

Design verification as per IEC/EN 61439

Technical data for design verification			
Rated operational current for specified heat dissipation	I_n	A	0
Heat dissipation per pole, current-dependent	P_{vid}	W	0
Equipment heat dissipation, current-dependent	P_{vid}	W	0
Static heat dissipation, non-current-dependent	P_{vs}	W	1.3
Heat dissipation capacity	P_{diss}	W	0
Operating ambient temperature min.		°C	0
Operating ambient temperature max.		°C	55
Degree of Protection			IP20
IEC/EN 61439 design verification			
10.2 Strength of materials and parts			
10.2.2 Corrosion resistance			
			Meets the product standard's requirements.
10.2.3.1 Verification of thermal stability of enclosures			
			Meets the product standard's requirements.
10.2.3.2 Verification of resistance of insulating materials to normal heat			
			Meets the product standard's requirements.
10.2.3.3 Verification of resistance of insulating materials to abnormal heat and fire due to internal electric effects			
			Meets the product standard's requirements.
10.2.4 Resistance to ultra-violet (UV) radiation			
			Meets the product standard's requirements.
10.2.5 Lifting			
			Does not apply, since the entire switchgear needs to be evaluated.
10.2.6 Mechanical impact			
			Does not apply, since the entire switchgear needs to be evaluated.
10.2.7 Inscriptions			
			Meets the product standard's requirements.
10.3 Degree of protection of ASSEMBLIES			
			Meets the product standard's requirements.
10.4 Clearances and creepage distances			
			Meets the product standard's requirements.
10.5 Protection against electric shock			
			Does not apply, since the entire switchgear needs to be evaluated.
10.6 Incorporation of switching devices and components			
			Does not apply, since the entire switchgear needs to be evaluated.
10.7 Internal electrical circuits and connections			
			Is the panel builder's responsibility.
10.8 Connections for external conductors			
			Is the panel builder's responsibility.
10.9 Insulation properties			
10.9.2 Power-frequency electric strength			
			Is the panel builder's responsibility.
10.9.3 Impulse withstand voltage			
			Is the panel builder's responsibility.
10.9.4 Testing of enclosures made of insulating material			
			Is the panel builder's responsibility.
10.10 Temperature rise			
			The panel builder is responsible for the temperature rise calculation. Eaton will provide heat dissipation data for the devices.
10.11 Short-circuit rating			
			Is the panel builder's responsibility.
10.12 Electromagnetic compatibility			
			Is the panel builder's responsibility.
10.13 Mechanical function			
			The device meets the requirements, provided the information in the instruction leaflet (IL) is observed.

Technical data ETIM 7.0

PLC's (EG000024) / Fieldbus, decentr. periphery - power supply/segment module (EC001600)

Supply voltage AC 50 Hz	V	0 - 0
Supply voltage AC 60 Hz	V	0 - 0
Supply voltage DC	V	18 - 30
Voltage type of supply voltage		DC
Number of HW-interfaces industrial Ethernet		0
Number of interfaces PROFINET		0
Number of HW-interfaces RS-232		0
Number of HW-interfaces RS-422		0
Number of HW-interfaces RS-485		0
Number of HW-interfaces serial TTY		0
Number of HW-interfaces parallel		0
Number of HW-interfaces Wireless		0
Number of HW-interfaces USB		0
Number of HW-interfaces other		1
With optical interface		No
Supporting protocol for TCP/IP		No
Supporting protocol for PROFIBUS		No
Supporting protocol for CAN		No
Supporting protocol for INTERBUS		No
Supporting protocol for ASI		No
Supporting protocol for KNX		No
Supporting protocol for MODBUS		No
Supporting protocol for Data-Highway		No
Supporting protocol for DeviceNet		No
Supporting protocol for SUCONET		No
Supporting protocol for LON		No
Supporting protocol for PROFINET IO		No
Supporting protocol for PROFINET CBA		No
Supporting protocol for SERCOS		No
Supporting protocol for Foundation Fieldbus		No
Supporting protocol for EtherNet/IP		No
Supporting protocol for AS-Interface Safety at Work		No
Supporting protocol for DeviceNet Safety		No
Supporting protocol for INTERBUS-Safety		No
Supporting protocol for PROFIsafe		No
Supporting protocol for SafetyBUS p		No
Supporting protocol for other bus systems		Yes
Radio standard Bluetooth		No
Radio standard WLAN 802.11		No
Radio standard GPRS		No
Radio standard GSM		No
Radio standard UMTS		No
System accessory		Yes
Degree of protection (IP)		IP20
Type of electric connection		Screw-/spring clamp connection
With potential separation		Yes
With power supply module		No
Suitable as segment module		Yes
Remote module		No
Fieldbus connection over separate bus coupler possible		Yes
Bus diagnosis possible		Yes
Rail mounting possible		Yes
Wall mounting/direct mounting		No
Front build in possible		No

Rack-assembly possible		No
Suitable for safety functions		No
Category according to EN 954-1		
SIL according to IEC 61508		None
Performance level acc. EN ISO 13849-1		None
Appendant operation agent (Ex ia)		No
Appendant operation agent (Ex ib)		No
Explosion safety category for gas		None
Explosion safety category for dust		None
Width	mm	12.6
Height	mm	74.1
Depth	mm	55.4

Approvals

Product Standards		UL 508; CSA-C22.2 No. 142; IEC/EN 6113-2; CE marking
UL File No.		E205091
UL Category Control No.		NRAQ, NRAQ7
CSA File No.		UL report applies to both US and Canada
CSA Class No.		2252-01, 2252-81
North America Certification		UL recognized, certified by UL for use in Canada
Specially designed for North America		No
Current Limiting Circuit-Breaker		No
Degree of Protection		IEC: IP20, UL/CSA Type: -

Dimensions

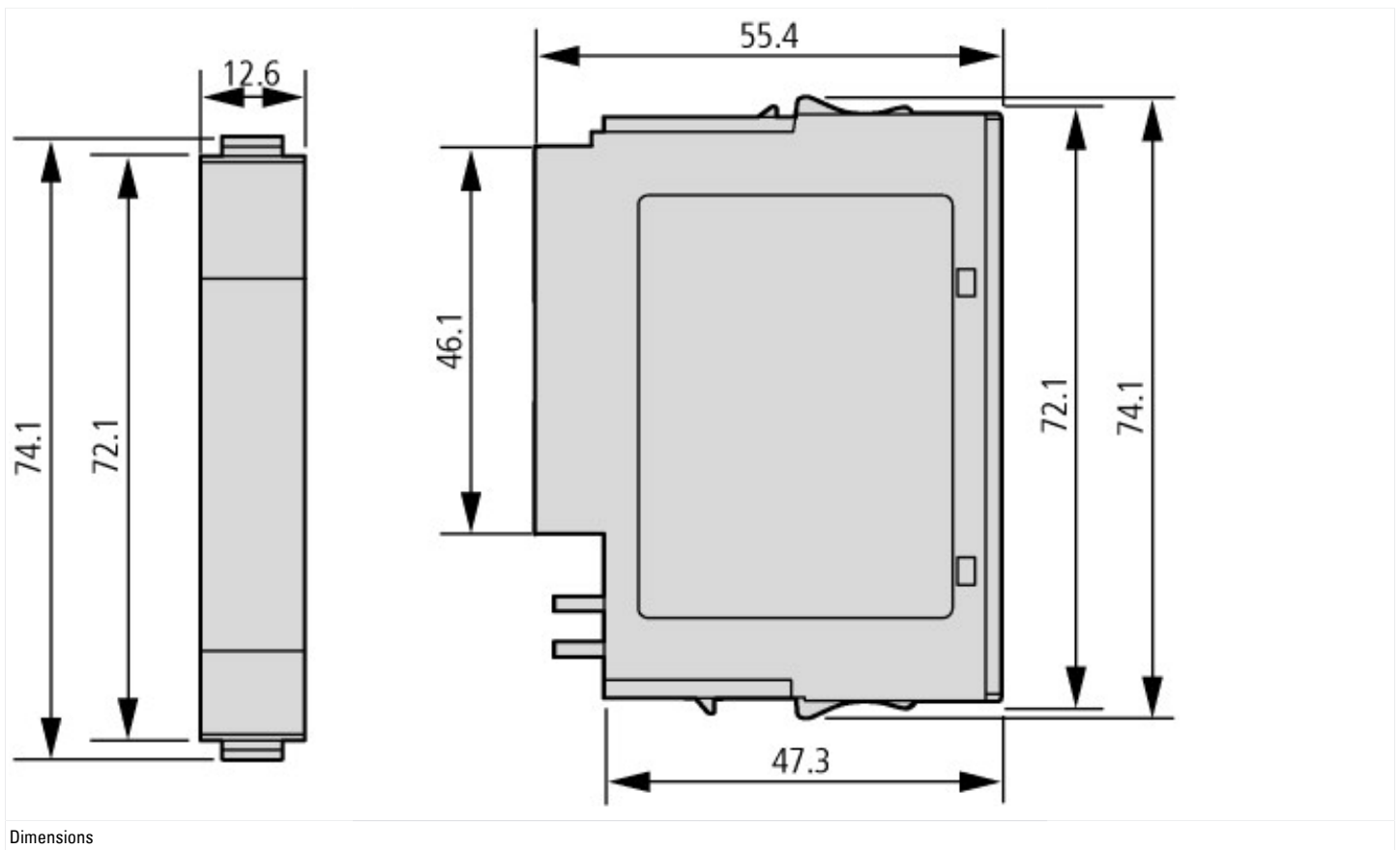

Assets (links)

Declaration of CE Conformity

00002416

Manuals

MN05002010Z_DE (German)

Additional product information (links)

Manual Digital XI/ON modules, power supply module MN05002010Z

Benutzerhandbuch XI/ON-Module, Stromversorgungsmodul MN05002010Z - Deutsch	ftp://ftp.moeller.net/DOCUMENTATION/AWB_MANUALS/MN05002010Z_DE.pdf
Manual Digital XI/ON modules, power supply module MN05002010Z - English	ftp://ftp.moeller.net/DOCUMENTATION/AWB_MANUALS/MN05002010Z_EN.pdf
Technical Data	http://ecat.moeller.net/flip-cat/?edition=HPLEN&startpage=14.111