



Central processing unit/power supply unit, 24 V DC, expandable, with easyNet, double memory like MFD-CP 8

Part no. **MFD-CP10-NT**  
 Catalog No. **133800**

EL-Nummer **4560808**  
 (Norway)

### Delivery program

Product range			Multi-function-display MFD-Titan
Basic function			Power supply unit/CPU modules
Subrange			CPU modules
Supply voltage			24 V DC
easyNet/easyLink			mit easyNet
Description			can be combined with display/operating unit MFD-80-.. and I/O module Expandable: Digital/analog inputs/outputs and AS-Interface, PROFIBUS-DP, CANopen®, DeviceNet bus systems Bussystem easyNet optional on board Program and screen memory Delivery with user program possible with MFD-COMBINATION product (Article no. 201801)
Description			Double program and screen memory, as MFD-CP8..., with easyNet
Connection type			screw terminal
Degree of Protection			IP20

### Technical data

#### General

Standards			EN 61000-6-1/-2/-3/-4, IEC 60068-2-6, IEC 60068-2-27
Dimensions (W x H x D)		mm	107.5 x 90 x 30
Weight		kg	0.145
Mounting			Fitted on the fixing shaft of the display or on top-hat rail according to IEC/EN 60715, 35 mm deep (without display)

#### Terminal capacities

Solid		mm <sup>2</sup>	0.24 (AWG 24 - 12)
Flexible with ferrule		mm <sup>2</sup>	0.22.5 (AWG 24 - 12)
Standard screwdriver		mm	3.5 x 0.6

#### Climatic environmental conditions

Operating ambient temperature		°C	-25 to 55, cold as per IEC 60068-2-1, heat as per IEC 60068-2-2
Condensation			Take appropriate measures to prevent condensation
Storage		°C	- 40 - 70
Relative humidity, non-condensing (IEC/EN 60068-2-30)		%	5 - 95
Air pressure (operation)		hPa	795 - 1080

#### Ambient conditions, mechanical

Protection type (IEC/EN 60529, EN50178, VBG 4)			IP20
Vibrations (IEC/EN 60068-2-6)		Hz	
Constant amplitude 0.15 mm		Hz	10 - 57
Constant acceleration 2 g		Hz	57 - 150
Mechanical shock resistance (IEC/EN 60068-2-27) semi-sinusoidal 15 g/11 ms		Impacts	18
Drop to IEC/EN 60068-2-31	Drop height	mm	50
Free fall, packaged (IEC/EN 60068-2-32)		m	1
Mounting position			Vertical or horizontal

#### Electromagnetic compatibility (EMC)

Electrostatic discharge (IEC/EN 61000-4-2, Level 3, ESD)		kV	
Air discharge		kV	8
Contact discharge		kV	6
Electromagnetic fields (RFI) to IEC EN 61000-4-3		V/m	10
Radio interference suppression			EN 55011 Class B, EN 55022 Class B
Burst Impulse (IEC/EN 61000-4-4, Level 3)			

Supply cable	kV	2
Signal lines	kV	2
Power pulses (surge) (IEC/EN 61000-4-5)	kV	2 (supply cables symmetrical, MFD-AC-CP8..)
power pulses (surge) (IEC/EN 61000-4-5, level 2)	kV	2 (supply cables symmetrical, MFD-AC-CP8..)
Immunity to line-conducted interference to (IEC/EN 61000-4-6)	V	10

### Insulation resistance

Clearance in air and creepage distances		EN 50178, UL 508, CSA C22.2, No. 142
Insulation resistance		EN 50178

### Back-up of real-time clock

Back-up of real-time clock			<p>① Backup time (hours) with fully charged double layer capacitor ② Service life (years)</p>
Accuracy of the real-time clock	s/day	Normally $\pm 5$ s/day ( $\pm 0.5$ h/year)	

### Repetition accuracy of timing relays

Accuracy of timing relays (of values)	%	$\pm 0.02$
Resolution		
Range "S"	ms	5
Range "M:S"	s	1
Range "H:M"	min	1

### Retentive memory

Write cycles of the retentive memory		$10^{10}$ (read/write cycles)
--------------------------------------	--	-------------------------------

### Power supply

Rated operational voltage	$U_e$	V	24 DC (-15/+20 %)
Admissible range		V DC	20.4 - 28.8
Residual ripple		%	$\leq 5$
Input current			
at 24 V DC		mA	Normally 200
Voltage dips		ms	10
Power loss			
Heat dissipation at 24 V DC		W	3.4

### Network easyNet

Stations	Number	max. 8
Data transfer rate/distance		1000 kBit/s, 6 m 500 Kbit/s, 25 m 250 Kbit/s, 40 m 125 kBit/s, 125 m 50 Kbit/s, 300 m 20 Kbit/s, 700 m 10 Kbit/s, 1000 m
Distance	m	5
Potential isolation		
From power supply		yes
From the inputs		yes
From the outputs		yes
to PC interface, memory card, easyNet, easyLink		yes
Bus termination (first and last station)		yes
Connection technique		RJ45, 8-pole

### Design verification as per IEC/EN 61439

Technical data for design verification			
Rated operational current for specified heat dissipation	$I_n$	A	0
Heat dissipation per pole, current-dependent	$P_{vid}$	W	0
Equipment heat dissipation, current-dependent	$P_{vid}$	W	0
Static heat dissipation, non-current-dependent	$P_{vs}$	W	3.4
Heat dissipation capacity	$P_{diss}$	W	0
Operating ambient temperature min.		°C	-25
Operating ambient temperature max.		°C	55

IEC/EN 61439 design verification		
10.2 Strength of materials and parts		
10.2.2 Corrosion resistance		Meets the product standard's requirements.
10.2.3.1 Verification of thermal stability of enclosures		Meets the product standard's requirements.
10.2.3.2 Verification of resistance of insulating materials to normal heat		Meets the product standard's requirements.
10.2.3.3 Verification of resistance of insulating materials to abnormal heat and fire due to internal electric effects		Meets the product standard's requirements.
10.2.4 Resistance to ultra-violet (UV) radiation		Meets the product standard's requirements.
10.2.5 Lifting		Does not apply, since the entire switchgear needs to be evaluated.
10.2.6 Mechanical impact		Does not apply, since the entire switchgear needs to be evaluated.
10.2.7 Inscriptions		Meets the product standard's requirements.
10.3 Degree of protection of ASSEMBLIES		Meets the product standard's requirements.
10.4 Clearances and creepage distances		Meets the product standard's requirements.
10.5 Protection against electric shock		Does not apply, since the entire switchgear needs to be evaluated.
10.6 Incorporation of switching devices and components		Does not apply, since the entire switchgear needs to be evaluated.
10.7 Internal electrical circuits and connections		Is the panel builder's responsibility.
10.8 Connections for external conductors		Is the panel builder's responsibility.
10.9 Insulation properties		
10.9.2 Power-frequency electric strength		Is the panel builder's responsibility.
10.9.3 Impulse withstand voltage		Is the panel builder's responsibility.
10.9.4 Testing of enclosures made of insulating material		Is the panel builder's responsibility.
10.10 Temperature rise		The panel builder is responsible for the temperature rise calculation. Eaton will provide heat dissipation data for the devices.
10.11 Short-circuit rating		Is the panel builder's responsibility.
10.12 Electromagnetic compatibility		Is the panel builder's responsibility.
10.13 Mechanical function		The device meets the requirements, provided the information in the instruction leaflet (IL) is observed.

## Technical data ETIM 7.0

PLC's (EG000024) / Graphic panel (EC001412)		
Electric engineering, automation, process control engineering / Display and control component / Panel (HMI) / Graphic panel (HMI) (ecl@ss10.0.1-27-33-02-01 [AFX016003])		
Supply voltage AC 50 Hz	V	0 - 0
Supply voltage AC 60 Hz	V	0 - 0
Supply voltage DC	V	20.4 - 28.8
Voltage type of supply voltage		DC
Number of HW-interfaces industrial Ethernet		0
Number of interfaces PROFINET		0
Number of HW-interfaces RS-232		0
Number of HW-interfaces RS-422		0
Number of HW-interfaces RS-485		0
Number of HW-interfaces serial TTY		0
Number of HW-interfaces USB		0
Number of HW-interfaces parallel		0
Number of HW-interfaces Wireless		0
Number of HW-interfaces other		4
With SW interfaces		Yes
Supporting protocol for TCP/IP		No
Supporting protocol for PROFIBUS		No
Supporting protocol for CAN		No
Supporting protocol for INTERBUS		No
Supporting protocol for ASI		No
Supporting protocol for KNX		No
Supporting protocol for MODBUS		No
Supporting protocol for Data-Highway		No
Supporting protocol for DeviceNet		No
Supporting protocol for SUCONET		No

Supporting protocol for LON			No
Supporting protocol for PROFINET IO			No
Supporting protocol for PROFINET CBA			No
Supporting protocol for SERCOS			No
Supporting protocol for Foundation Fieldbus			No
Supporting protocol for EtherNet/IP			No
Supporting protocol for AS-Interface Safety at Work			No
Supporting protocol for DeviceNet Safety			No
Supporting protocol for INTERBUS-Safety			No
Supporting protocol for PROFIsafe			No
Supporting protocol for SafetyBUS p			No
Supporting protocol for other bus systems			Yes
Radio standard Bluetooth			No
Radio standard WLAN 802.11			No
Radio standard GPRS			No
Radio standard GSM			No
Radio standard UMTS			No
IO link master			No
Type of display			Other
With colour display			No
Number of colours of the display			0
Number of grey-scales/blue-scales of display			0
Screen diagonal		inch	0
Number of pixels, horizontal			0
Number of pixels, vertical			0
Useful project memory/user memory		kByte	64
With numeric keyboard			No
With alpha numeric keyboard			No
Number of function buttons, programmable			9
Number of buttons with LED			0
Number of system buttons			0
Touch technology			None
With message indication			Yes
With message system (incl. buffer and confirmation)			No
Process value representation (output) possible			Yes
Process default value (input) possible			Yes
With recipes			No
Number of password levels			1
With printer output			No
Number of online languages			256
Additional software components, loadable			Yes
Degree of protection (IP), front side			IP20
Degree of protection (NEMA), front side			1
Operation temperature		°C	25 - 55
Rail mounting possible			Yes
Wall mounting/direct mounting			No
Suitable for safety functions			No
Width of the front		mm	0
Height of the front		mm	0
Built-in depth		mm	25

## Approvals

Product Standards			IEC/EN see Technical Data; UL 508; CSA C22.2 No. 142-M1987; CSA C22.2 No. 213-M1987; CE marking
UL File No.			E135462
UL Category Control No.			NRAQ

CSA File No.		012528
CSA Class No.		2252-01 + 2258-02
North America Certification		Request filed for UL and CSA
Degree of Protection		IEC: IP20, UL/CSA Type: -

## Dimensions

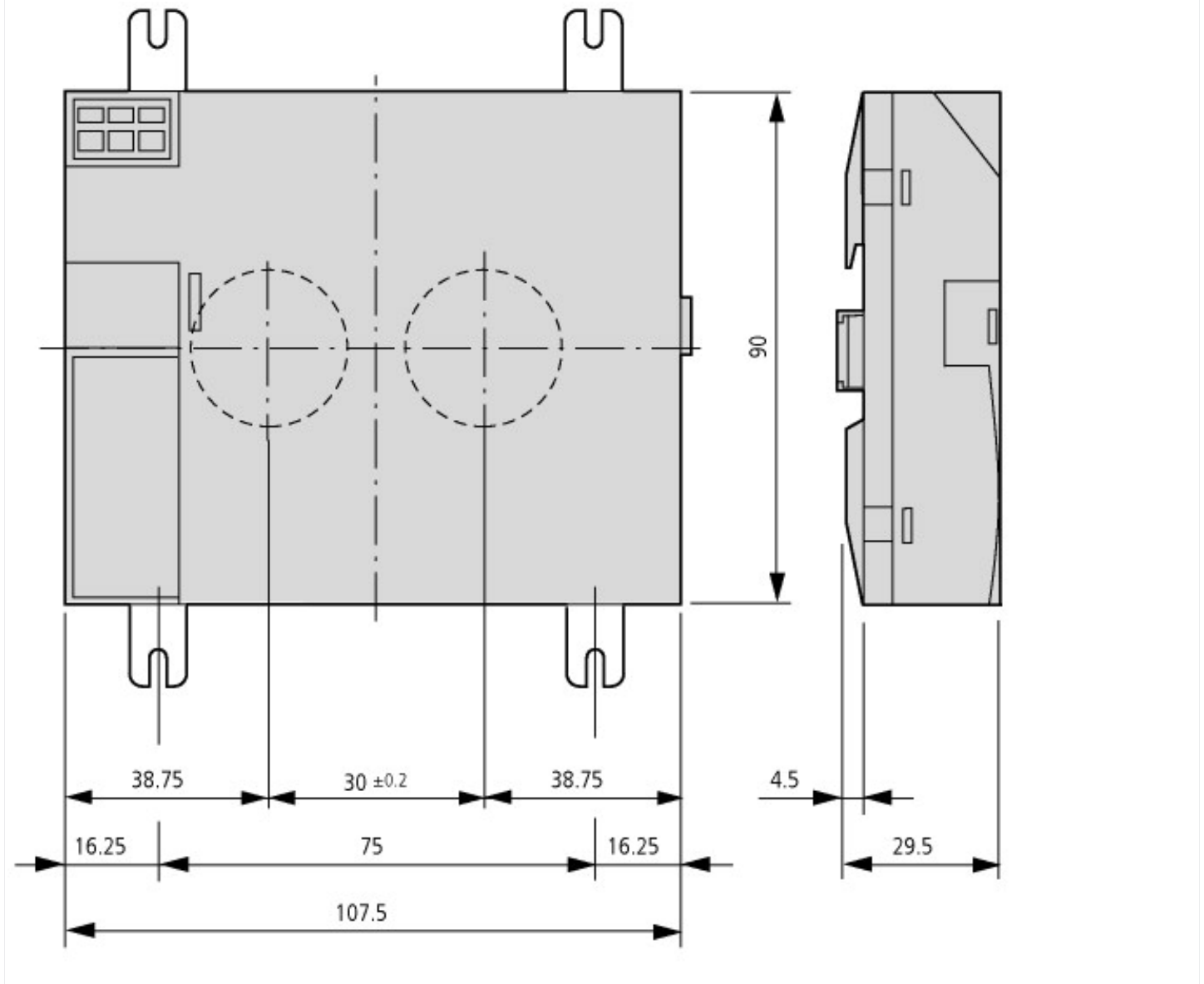

## Additional product information (links)

### Instruction leaflet "Multi-function display, easy control relays" IL05013014Z (AWA2528-2019)

Instruction leaflet "Multi-function display, easy control relays" IL05013014Z (AWA2528-2019) [https://es-assets.eaton.com/DOCUMENTATION/AWA\\_INSTRUCTIONS/IL05013014Z2018\\_02.pdf](https://es-assets.eaton.com/DOCUMENTATION/AWA_INSTRUCTIONS/IL05013014Z2018_02.pdf)

### Instruction leaflet "power supply unit, communication module" IL05013018Z (AWA2528-2175)

Instruction leaflet "power supply unit, communication module" IL05013018Z (AWA2528-2175) [https://es-assets.eaton.com/DOCUMENTATION/AWA\\_INSTRUCTIONS/IL05013018Z2018\\_02.pdf](https://es-assets.eaton.com/DOCUMENTATION/AWA_INSTRUCTIONS/IL05013018Z2018_02.pdf)

### Manual "MFD-Titan multi-function display" MN05002001Z (AWB2528-1480)

Handbuch „Multifunktions-Display MFD-Titan“ MN05002001Z (AWB2528-1480) - Deutsch [https://es-assets.eaton.com/DOCUMENTATION/AWB\\_MANUALS/MN05002001Z\\_DE.pdf](https://es-assets.eaton.com/DOCUMENTATION/AWB_MANUALS/MN05002001Z_DE.pdf)

Manual "MFD-Titan multi-function display" MN05002001Z (AWB2528-1480) - English [https://es-assets.eaton.com/DOCUMENTATION/AWB\\_MANUALS/MN05002001Z\\_EN.pdf](https://es-assets.eaton.com/DOCUMENTATION/AWB_MANUALS/MN05002001Z_EN.pdf)

f1=1454&f2=1179;Labeleditor <http://applications.eaton.eu/sdlc?LX=11&f1=1454&f2=1179;Labeleditor>

Product overview (WEB) <http://www.eaton.eu/mfd>