

OTS/bell alarm in IZM low voltage circuit breakers

⚠ WARNING

(1) **ONLY QUALIFIED ELECTRICAL PERSONNEL SHOULD BE PERMITTED TO WORK ON THE EQUIPMENT.**
 (2) **ALWAYS DE-ENERGIZE PRIMARY AND SECONDARY CIRCUITS IF A CIRCUIT BREAKER CANNOT BE REMOVED TO A SAFE WORK LOCATION.**
 (3) **DRAWOUT CIRCUIT BREAKERS SHOULD BE LEVERED (RACKED) OUT TO THE DISCONNECT POSITION.**
 (4) **ALL CIRCUIT BREAKERS SHOULD BE SWITCHED TO THE OFF POSITION AND MECHANISM SPRINGS DISCHARGED.**
FAILURE TO FOLLOW THESE STEPS FOR ALL PROCEDURES DESCRIBED IN THIS INSTRUCTION LEAFLET COULD RESULT IN DEATH, BODILY INJURY, OR PROPERTY DAMAGE.

Section 1: General information

An overcurrent trip switch (bell alarm) provides an electrical indication when a circuit breaker trips as a result of the trip unit reacting to an overcurrent condition. Opening as a result of a circuit breaker's manual open button, shunt trip, or undervoltage release does **not** cause the overcurrent trip switch to operate.

Section 2: Installation of OTS/bell alarm

To install the OTS/bell alarm, proceed with the following five steps:

Step 1: Remove the front cover by unscrewing the hex-head captive bolts (four for three-pole, six for four-pole) that join the cover to the breaker housing using a 10 mm 1/4-inch drive socket. Then hold the charge handle down to pull off the cover.

Step 2: Place the appropriate label on the front cover nameplate space located under "Accessories."

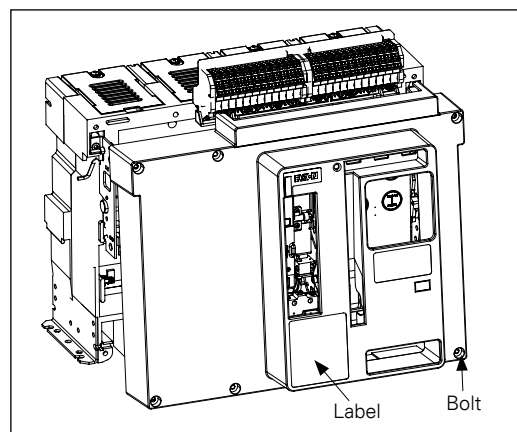

Figure 1. Steps 1 and 2

Step 3: With the red reset button in the forward position, mount the two switches using M2.5 x 20 mm self-tapping screws.

Step 4: Wire the switches blue plugs to secondary block, terminals 5 through 10, per markings on the wires.

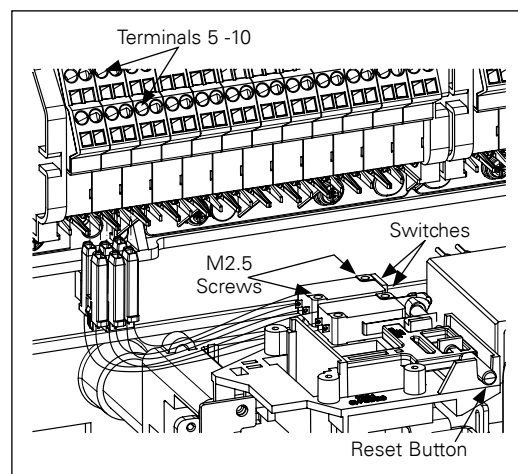

Figure 2. Steps 3 and 4

Step 5: Reinstall the front cover.

EATON

Powering Business Worldwide

Disclaimer of warranties and limitation of liability

The information, recommendations, descriptions, and safety notations in this document are based on Eaton Corporation's ("Eaton") experience and judgment, and may not cover all contingencies. If further information is required, an Eaton sales office should be consulted.

Sale of the product shown in this literature is subject to the terms and conditions outlined in appropriate Eaton selling policies or other contractual agreement between Eaton and the purchaser.

THERE ARE NO UNDERSTANDINGS, AGREEMENTS, WARRANTIES, EXPRESSED OR IMPLIED, INCLUDING WARRANTIES OF FITNESS FOR A PARTICULAR PURPOSE OR MERCHANTABILITY, OTHER THAN THOSE SPECIFICALLY SET OUT IN ANY EXISTING CONTRACT BETWEEN THE PARTIES. ANY SUCH CONTRACT STATES THE ENTIRE OBLIGATION OF EATON.

THE CONTENTS OF THIS DOCUMENT SHALL NOT BECOME PART OF OR MODIFY ANY CONTRACT BETWEEN THE PARTIES.

In no event will Eaton be responsible to the purchaser or user in contract, in tort (including negligence), strict liability, or otherwise for any special, indirect, incidental, or consequential damage or loss whatsoever, including but not limited to damage or loss of use of equipment, plant or power system, cost of capital, loss of power, additional expenses in the use of existing power facilities, or claims against the purchaser or user by its customers resulting from the use of the information, recommendations, and descriptions contained herein.

The information contained in this manual is subject to change without notice.

Eaton Industries GmbH
Hein-Moeller-Straße 7-11,
53115 Bonn,
Germany
Eaton.com

© 2021 Eaton Industries GmbH
All Rights Reserved
Printed in Germany
Publication No. IL0131173EN
Effective December 2021