



(en) Electric current! Danger to life!
Installation, commissioning and maintenance work must be carried out by qualified personnel only.

(de) Lebensgefahr durch elektrischen Strom!
Arbeiten bzw. Montage an diesem Produkt dürfen nur von Elektrofachkräften und elektrotechnisch unterwiesenen Personen ausgeführt werden.

(fr) Tension électrique dangereuse !
L'installation de l'appareil, ainsi que tous les travaux effectués sur celui-ci, doivent être réalisés par un électricien qualifié ou par un personnel spécialement formé.

(es) ¡Corriente eléctrica! ¡Peligro de muerte!
La instalación del dispositivo, así como todos los trabajos en él, deben ser realizados por un electricista calificado o por personal especialmente capacitado.

(it) Tensione elettrica: Pericolo di morte!
L'installazione e il lavoro sul dispositivo devono essere effettuati da un elettricista qualificato o da personale specializzato.

(zh) 触电危险!
設備的安裝，以及所有工作，必須由合格的電工或經過專門培訓的人員完成。

(ru) Электрический ток! Опасно для жизни!
Установка и эксплуатация устройства должны выполняться квалифицированным электриком или специально обученным персоналом.

(nl) Levensgevaar door elektrische stroom!
Installatie van het apparaat en alle werkzaamheden eraan, mogen uitsluitend door een gekwalificeerd elektricien of speciaal opgeleid vakpersoneel worden uitgevoerd.

(da) Livsfare på grund af elektrisk strøm!
Arbejde i forbindelse med installation, opstart og vedligehold må kun udføres af kvalificeret personale.

(el) Προσοχή, κίνδυνος ηλεκτροπληξίας!
Η εγκατάσταση, εκκίνηση και συντήρηση θα πρέπει να πραγματοποιείται μόνο από εξειδικευμένο προσωπικό.

(pt) Perigo de vida devido a corrente elétrica!
A instalação do dispositivo, bem como todos os trabalhos devem ser realizados por um electricista qualificado ou por pessoal especialmente formado.

(sv) Livsfara genom elektrisk ström!
Installation, idrifttagande och underhållsarbete får endast utföras av behörig personal.

(fi) Hengenvaarallinen jännite!
Laitteen asennus ja käyttö ainoastaan sähköasentajan tai siihen perehdytetyn henkilön toimesta.

(cs) Nebezpečí úrazu elektrickým proudem!
Instalace zařízení a veškeré práce na něm musí být provedeny kvalifikovaným elektrikářem nebo speciálně vyškoleným personálem.

(et) Eluhtlik! Elektrilöögiht!
Paigaldus-, kasutus- ja hooldustööd peab läbi viima ainult kvalifitseeritud personal.

(hu) Életveszély az elektromos áram révén!
Az eszköz felszerelését, valamint az ehhez kapcsolódó összes munkát szakképzett villanyszerelővel vagy szakképzett személynél kell elvégeznie.

(lv) Elektriskā strāva apdraud dzīvību!
Uzstādīšana, nodošana ekspluatācijā un apkopes darbi jāveic tikai kvalificētam personālam.

(lt) Pavojus gyvybei dėl elektros srovės!
Įrengimo, paleidimo ir techninės priežiūros darbus turi atlikti tik kvalifikuotas personalas.

(pl) Porażenie prądem elektrycznym stanowi zagrożenie dla życia!
Instalacja urządzenia, jak również prace nad nim, muszą być wykonywane przez wykwalifikowanego elektryka lub specjalnie wyszkolony personel.

(sl) Življenjska nevarnost zaradi električnega toka!
Dela montaže, zagona in vzdrževanja morajo izvajati samo usposobljeno osebe.

(sk) Nebezpečnosť ohrozenia života elektrickým prúdom!
Inštalácia prístroja, ako aj všetky práce na ňom musia byť vykonané kvalifikovaným elektrotechnikom alebo špeciálne vyškoleným personálom.

(bg) Опасност за живота от електрически ток!
Инсталирането на устройството, както и всяка работа по него, трябва да бъде извършвано от квалифициран електротехник или от специално обучен персонал.

(ro) Atenție! Pericol electric!
Montajul și lucrul cu acest aparat trebuie făcute numai de un electrician calificat sau de personal tehnic specializat.

(hr) Opasnost po život uslijed električne struje!
Radove ugradnje, puštanja u pogon i održavanja mora vršiti samo kvalificirano osoblje.

(tr) Elektrik akımı! Hayati tehlike!
Bu ürünün çalıştırılması veya kurulumu sadece elektroteknik eğitimleri almış olan ehliyetli elektrikçiler ve kişiler tarafından yapılmalıdır.

(sr) Električna struja! Opasnost po život!
Arbeiten bzw. Montage und dijesem Produkt darf od Elektrofaçhkräften und elektrotechnisçx unterwiesenen Personon ausgefuhrt werden.

(no) Elektrisk strøm! Livsfare!
Installasjon av enheten, samt arbeid på den, skal kun utføres av kvalifisert personell, eller av de som er spesielt opplært til dette arbeidet.

(uk) Електричний струм! Небезпечно для життя!
Встановлення пристрою, так само, як і робота з ним, повинні виконуватись кваліфікованим електриком або персоналом, що пройшов спеціальну підготовку.

(ar) تحذير! تيار كهربائي! خطر موت الشبيبة والتكليف و أعمال الصيانة يجب أن تقام فقط من طرف الموظفين المؤهلين

NZMN(S)(H)(L)3(-4)-AX(MX)(VX)(PX)(PMX)...
NZM(C)(N)(S)3(-4)-A(S)...
(P)N3-...

NZMN(H)(L)3-AX(MX)(VX)(PX)(PMX)...-NA
NS3-...-NA

NZM(N)(H)3-A(AF)...(-BT)-NA
NZM(N)3-S...(-BT)-CNA

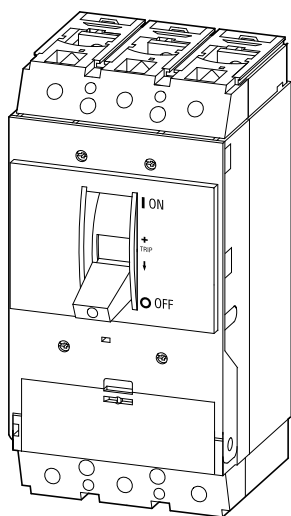

Minimum clearance/direction of blow-out

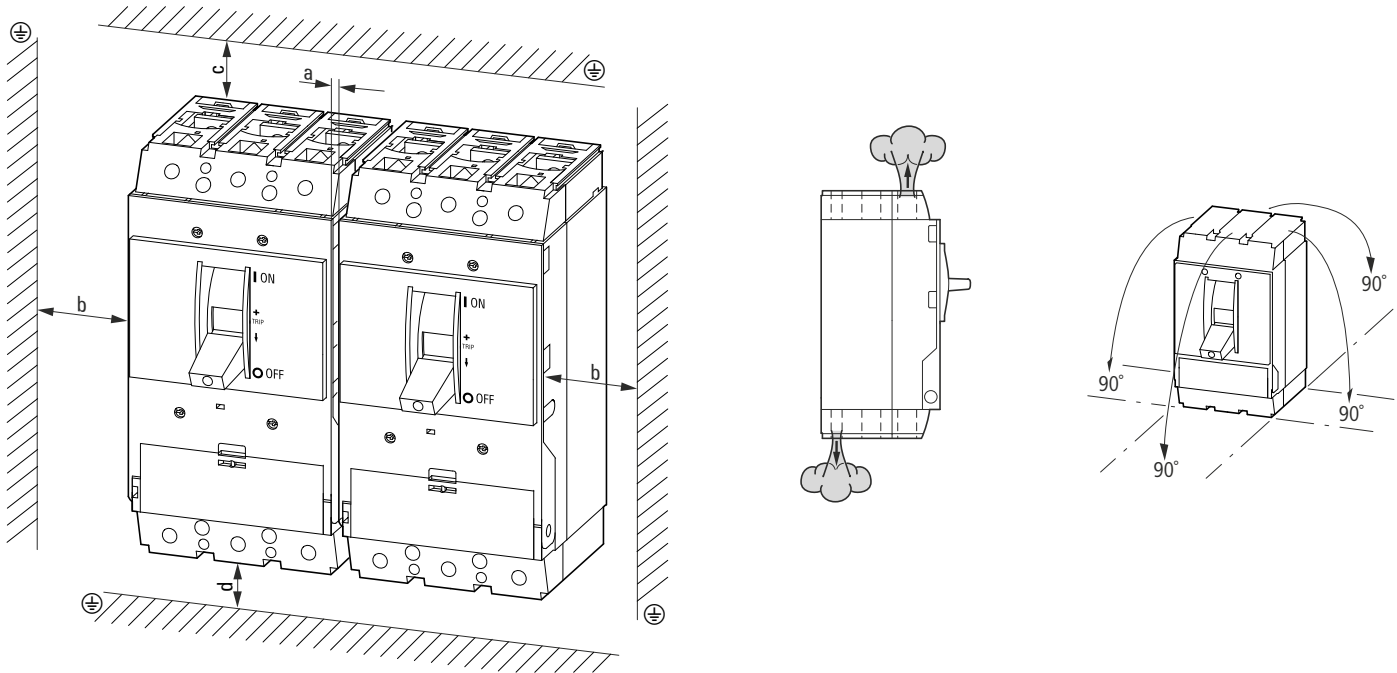

	a	b		c		d		
		≤ 690 V	1000 V	≤ 440 V	≤ 690 V	1000 V	≤ 690 V	1000 V
NZM3	5 mm (0.2")	5 mm (0.2")	5 mm (0.2")	30 mm (1.18")	60 mm (2.36")	60 mm (2.36")	60 mm (2.36")	60 mm (2.36")

Terminals

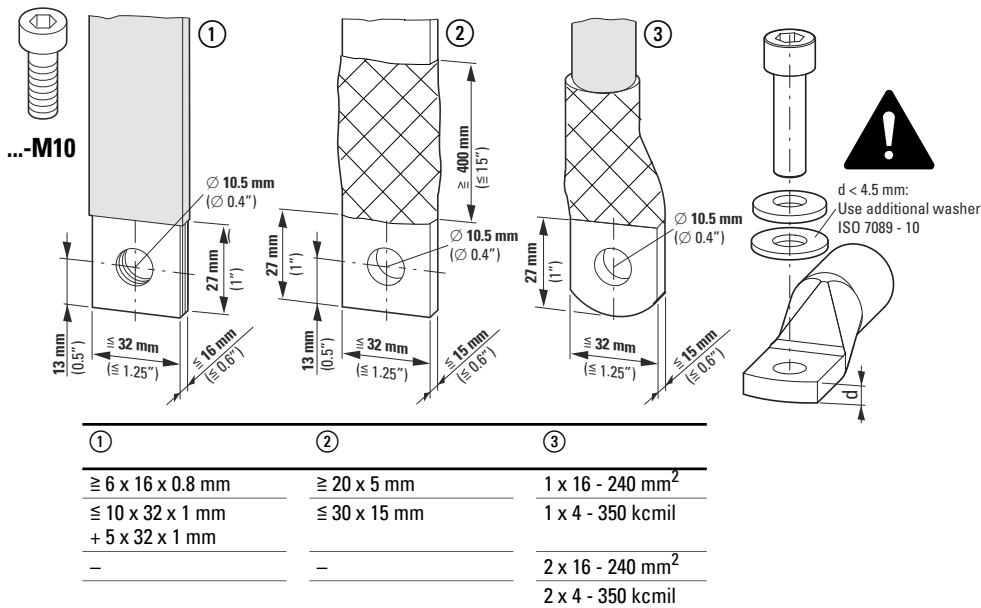

		A	
3pol	M10 x 35	185 mm ²	NZM3-XKS185
4pol		240 mm ²	NZM3-XKS240

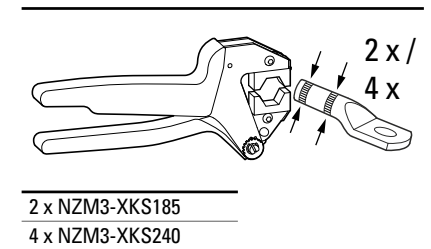

2 x NZM3-XKS185
4 x NZM3-XKS240

Wiring terminations circuit breaker type NZM...3...-NA (CNA) Wiring terminations molded case switch type NS3...-NA

Connector type	Wire size	Wire 75° C	Max. A-Rating	Tightening-Torque
1) Bolt on			600	31 Nm (275 lb-in)
NZM3-XKA2	1 x AWG 1/0 - 500 kcmil	Cu only	250	31 Nm (275 lb-in)
NZM3-XKC	1 x AWG 1/0 - 500 kcmil 2 x AWG 6 - 250 kcmil	Cu only	250	19 Nm (168 lb-in)
2) Integrated Auxiliary Terminal	1 x AWG 12 - 18	Cu only		1.2 Nm (11 lb-in)

- 1) Connector Pads Type NZM2-XKS for Compression Crimp lugs supplied standard on all NZM2 circuit breakers and switches.
- 2) Integrated Auxiliary Terminal on Barrel (Tunnel) Mechanical lug Connector Type NZM2-XKA only.

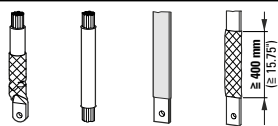
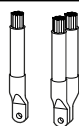
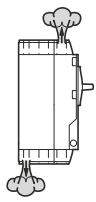

$\cong 415\text{ V}$ 		
$\cong 525\text{ V}$ 		
$\cong 690\text{ V}$ 		
$> 690\text{ V}$ 		

02/23 IL012100ZU

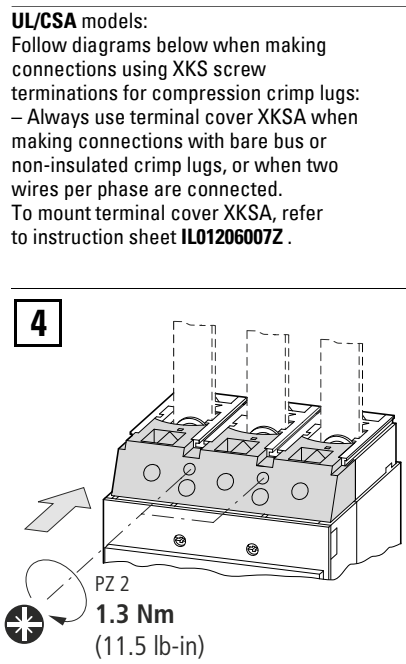
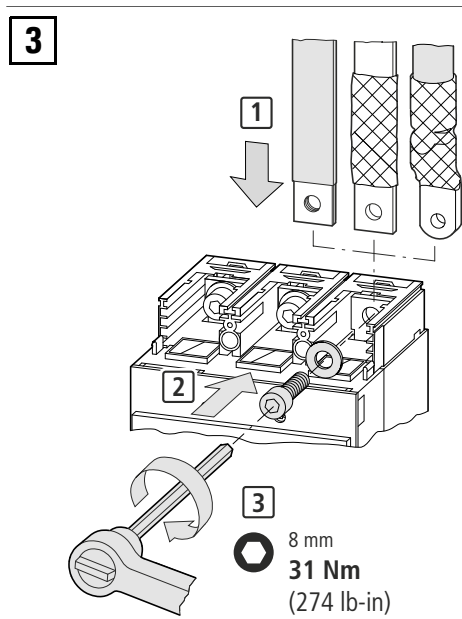
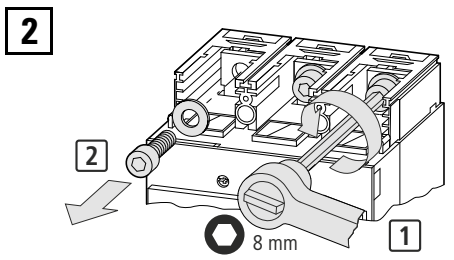
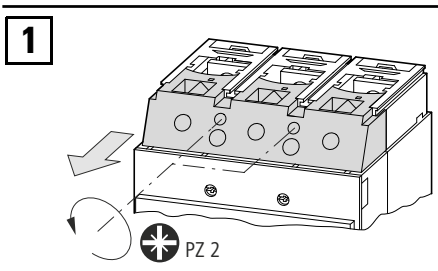

UL/CSA models:
 Follow diagrams below when making connections using XKS screw terminations for compression crimp lugs:
 – Always use terminal cover XKSA when making connections with bare bus or non-insulated crimp lugs, or when two wires per phase are connected.
 To mount terminal cover XKSA, refer to instruction sheet **IL01206007Z**.

Settings

NZM...3(-4)-A(S)...

NZM...3-A(AF)...-NA

NZM...3-S...-CNA

1

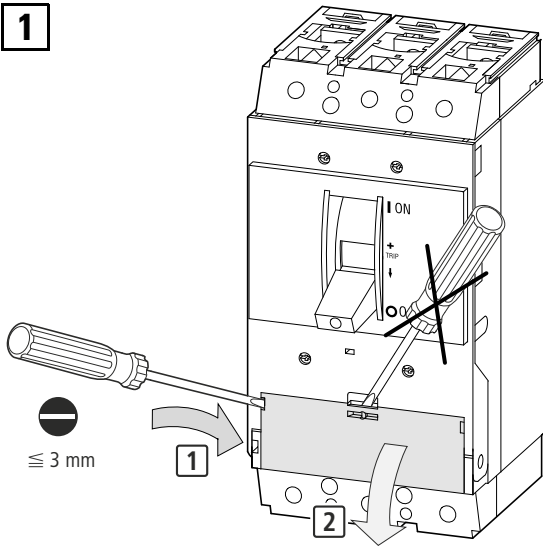

2

I_r [A]
Thermal

I_i [A]
Magnetic

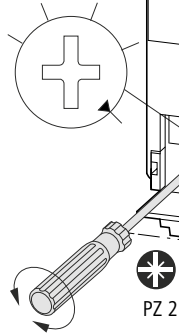

Note: On certain models with UL/CSA labeling the thermal trip setting is fixed and only the magnetic trip (instantaneous) setting is adjustable.

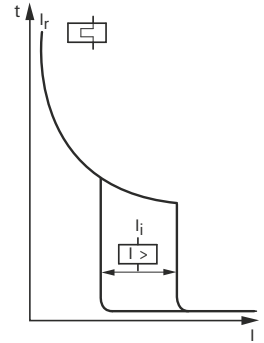

NZM...3(-4)-AX(MX)(VX)(PX)(PMX)...(-NA)

1

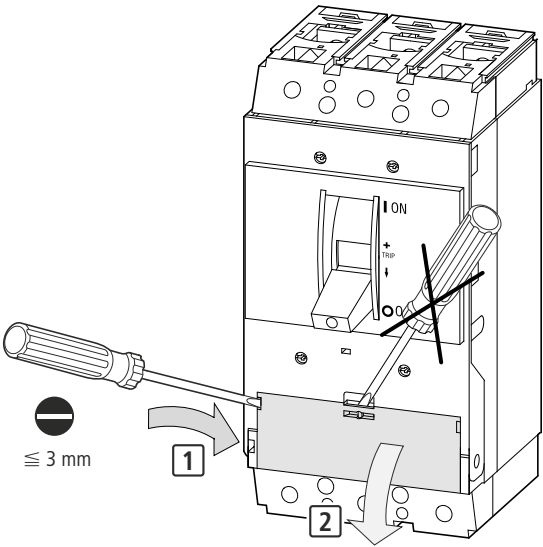

2

I_r [A], t_r [s], I_{sd} [A], t_{sd} [ms], I_i [A], I_g [A], t_g [ms]
Electronic Trip Circuit
Breaker Adjustable settings

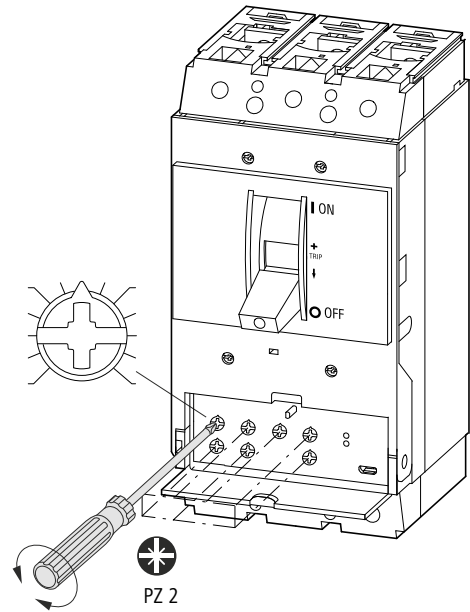

02/23 IL012100ZU

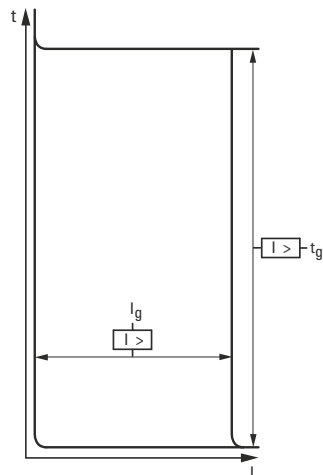
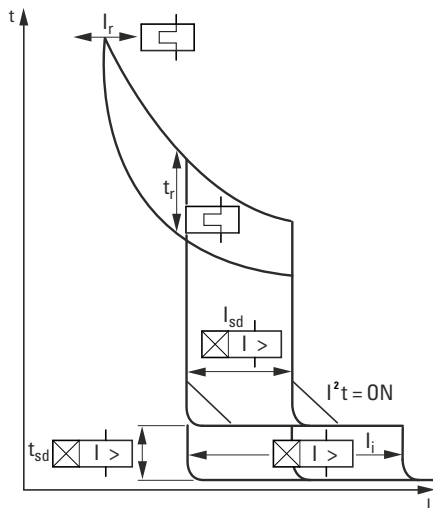

PXR10/20: NZM3...AX, MX, VX

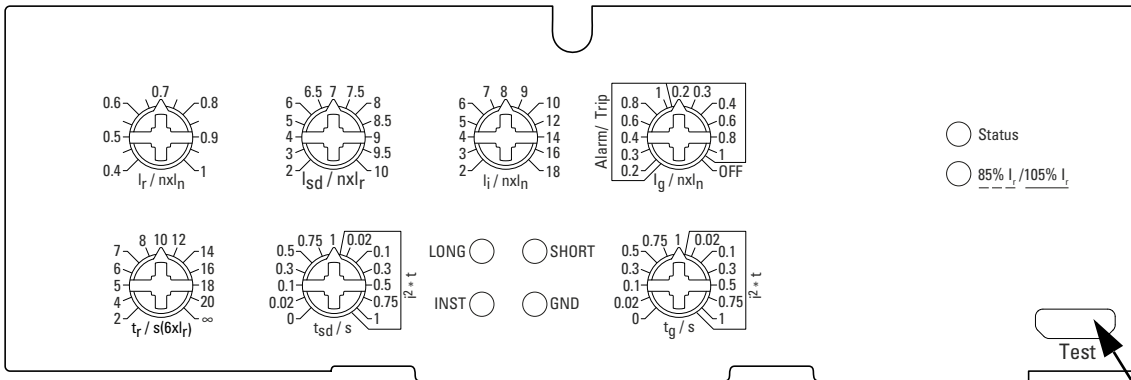

		I_r	t_r	I_{sd}	t_{sd}	I_i	I_g	t_g
PXR10	-AX(-NA)	x	-	-	-	x	-	-
PXR20	-MX(-NA)	x	x	-	-	x	-	-
	-VX(-NA)	x	x	x	x	x	-	-
	-VX-T(-NA)	x	x	x	x	x	x	x

Micro-USB
 ↓
 Power Xpert
 Protection Manger
www.eaton.com/PXPM

PXR25: NZM3...PX, PMX...



		I_r	t_r	I_{sd}	t_{sd}	I_i	I_g	t_g
PXR25	-PX(-NA)	x	x	x	x	x	-	-
	-PMX(-NA)	x	x	-	-	x	-	-
	-PX-TAZ(-NA)	x	x	x	x	x	x	x

02/23 IL012100ZU

	L		S		I	G	
	I_r	t_r/s	I_{sd}	t_{sd}/ms	I_i	I_g	t_g/ms
↔	0.4 - 1	2 - 20	2 - 10	0 - 1000	2 - 18	0.2 - 1	0 - 1000
→	1 A	0.1	1 A	10	1 A	1 A	10
	i^2t		it/i^2t			Alarm / Trip	it/i^2t
OFF	∞					OFF	

Energy metering

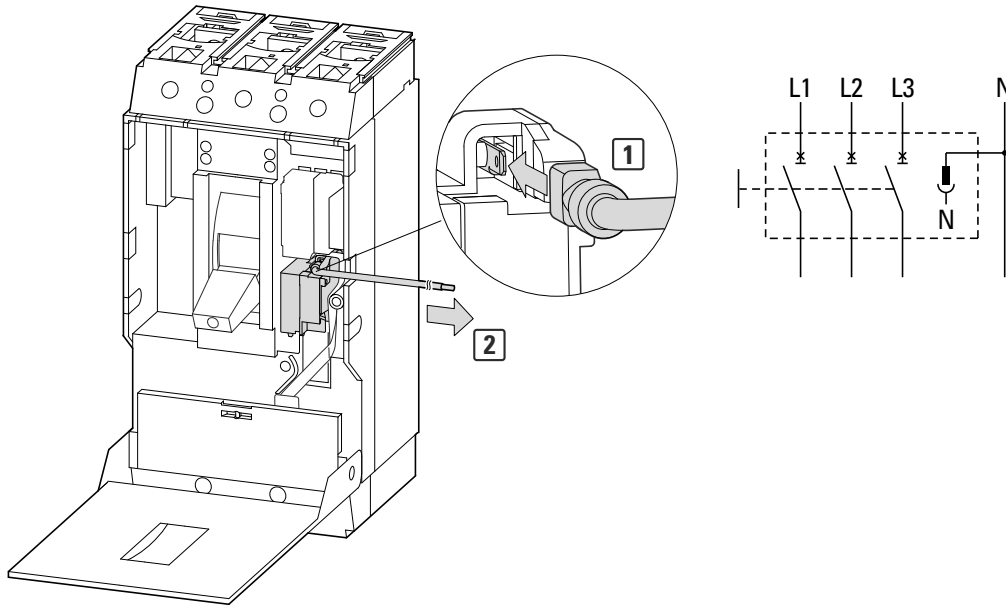

Accessories

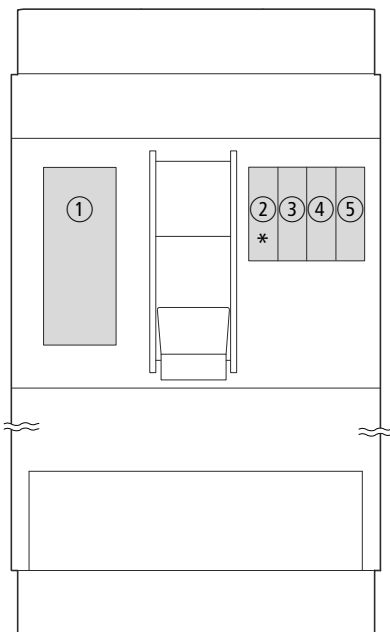

M22-(C)K...	-
M22-CK20(02,11)	-
NZM...-XHIV(-PI)	✓
NZM...-XA...(-PI)	✓
NZM...-XAHIV...(-PI)	✓
NZM...-XU...(-PI)	✓
NZM...-XUHIV...(-PI)	✓
NZM...-X2A...	✓
NZM...-XA2A...	✓
NZM...-XU2A...	✓
NZM...-XUHIV2A...	✓
NZM...-XPS...	-
NZM...-XBSM...	-
PXR-RCAM-MRTU-I	-
* PN3	-

①
XA
XU
XHIV
X2A

②	③	④	⑤
4.1	1.1	1.2	1.3
HIA	HIN	HIN	HIN
BSM	BSM	COM	

✓	✓	✓	✓
✓	✓	✓	✓
-	-	-	-
-	-	-	-
-	-	-	-
-	-	-	-
-	-	-	-
-	-	-	-
-	-	-	-
-	-	-	-
-	-	-	-
-	-	-	-
-	✓	-	-
-	✓	-	-
-	-	✓	-

M22-...

M22-K10 ...-K01
M22-CK10 ...-CK01

IEC $I_{th} = I_e$

	U_e (V)	I_e (A)
AC-15	115	4
	230	4
	400	2
	500	1
DC-13	24	3
	42	1.7
	60	1.2
	110	0.6
	220	0.3

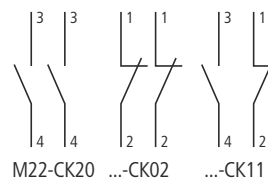

IEC $I_{th} = I_e$

	U_e (V)	I_e (A)
AC-15	115	4
	230	4
DC-13	24	3
	42	1
	60	0.8
	110	0.5
	220	0.2

Notes on mounting and wiring Auxiliary Switches for UL/CSA labeled models:

- M22-K(10)(01) have screw terminals. M22-CK(10)(01)(20)(02)(11) have clamp terminals.
- Switch modules are snapped into place at the locations shown in the diagrams that follow.
- Switches will function as either "standard" or "trip/alarm" contacts depending on their mounting location.
- Location "HIN" refers to standard operation. Location "HIA" refers to "trip/alarm" operation.
- Follow the numbering and wiring scheme provided above depending on the contact location and function. (N.O. or N.C.)
- Permissible contact configuration: 1 HIA and/or 2 HIN.



Note:

After mounting of the M22... switch is complete, check off the appropriate box on the auxiliary switch label provided on the side of the breaker or switch.

-NA
-CNA
(UL/CSA)



$I_{th} = I_e$

U_e (V)	I_e (A)
600 AC	5 A
250 DC	1 A

Pilot Duty Ratings:
B 600, Q 300
Above 300 V AC
Same polarity

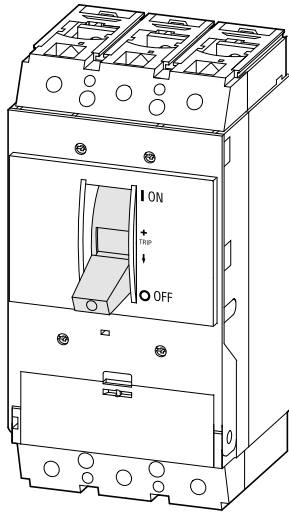
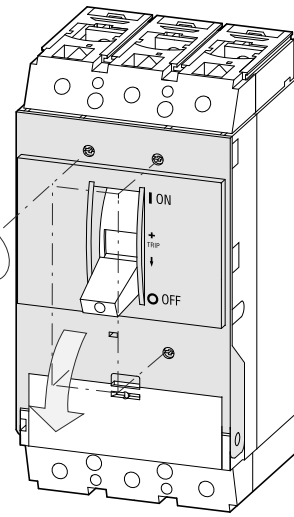
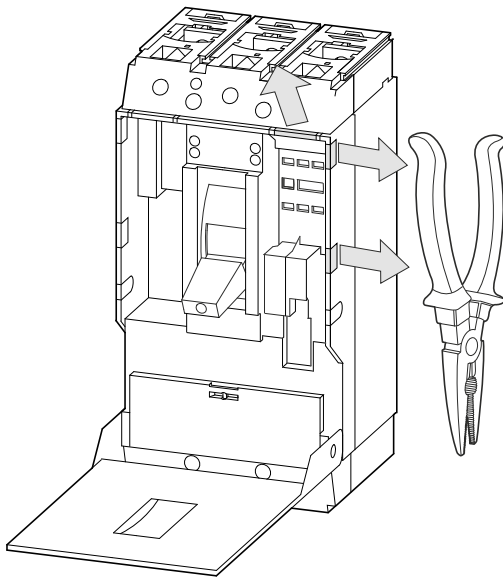
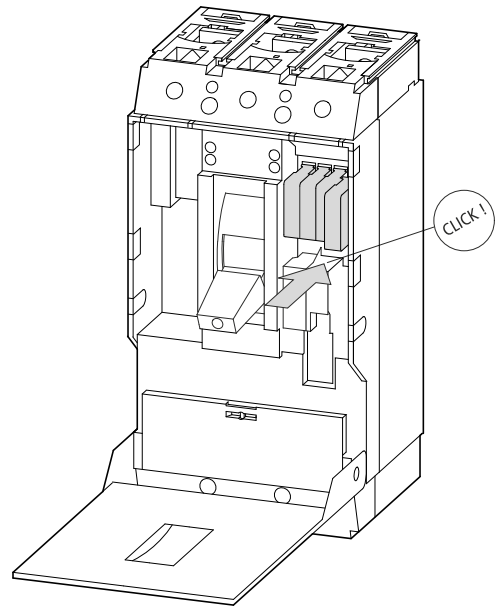
1**2****3****4**

02/23 IL012100ZU

5a

M22-K10, M22-K01 (Screw Terminals)

	a = 6 - 10 mm (a = 0.24 - 0.4")
	2 x 0.75 - 2.5 mm ² 2 x AWG 18 - AWG 14
UL/CSA = Cu only	

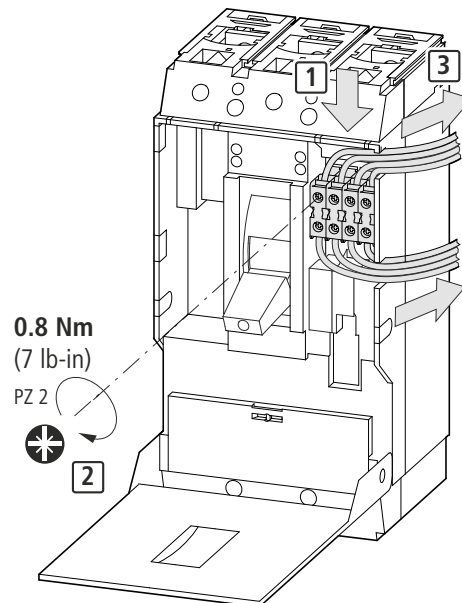

5b**M22-CK10, M22-CK01**

(Clamp Terminals)

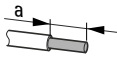
a  **a = 8 mm**
(a = 0.3")

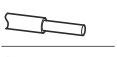
 2 x 0.75 - 2.5 mm²
2 x AWG 18 - AWG 14

 2 x 0.5 - 0.75 mm²
2 x AWG 20 - AWG 18

UL/CSA = Cu only

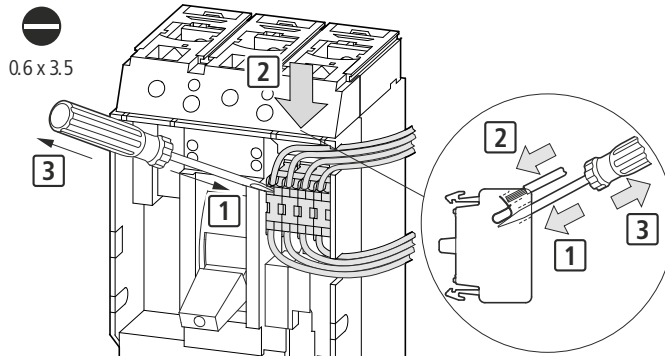
**5c****M22-CK11, M22-CK20, M22-CK02**

(Clamp Terminals)

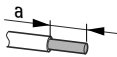
a  **a = 8 mm**
(a = 0.3")

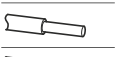
 1 x 0.5 - 1.5 mm²
1 x AWG20 - AWG16

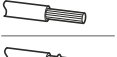
 2 x 0.5 - 0.75 mm²
2 x AWG20 - AWG18

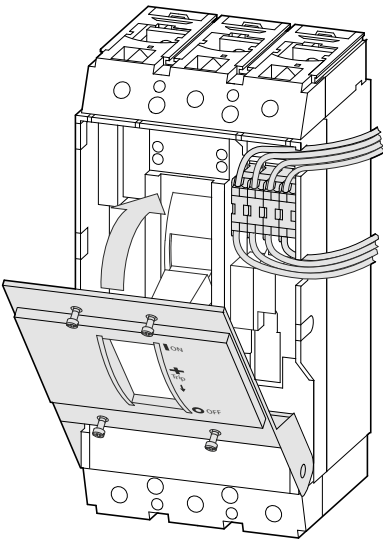
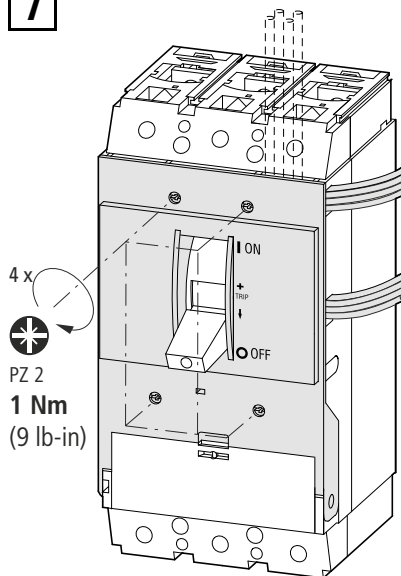
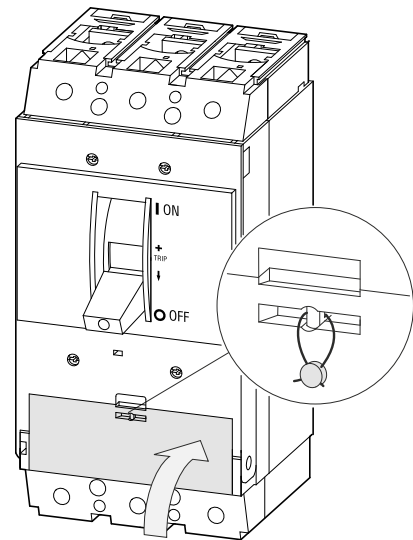
6**7****8**

02/23 IL012100ZU

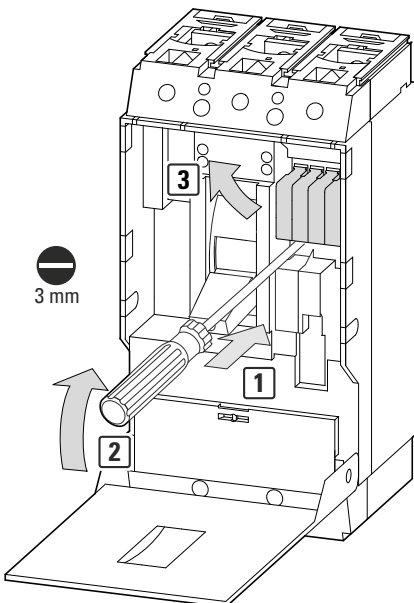
Dismounting

Test

1

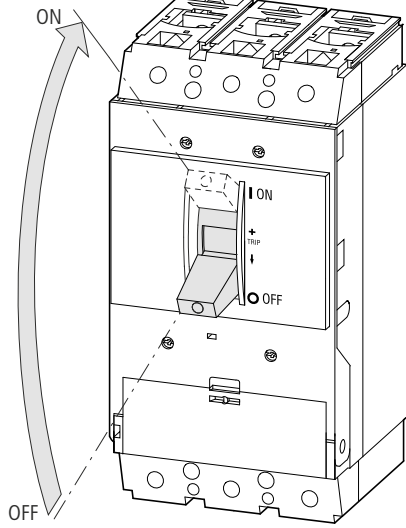

2

PN3

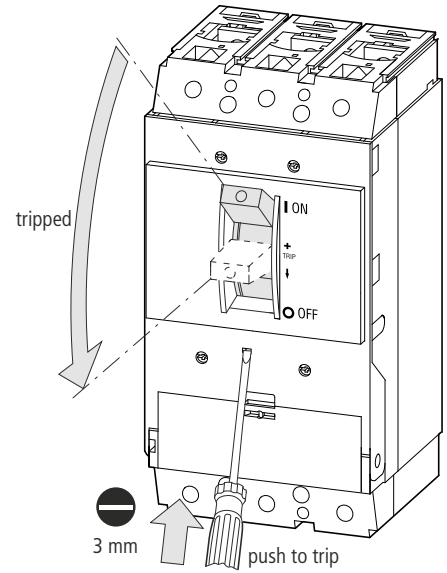

3

PN3

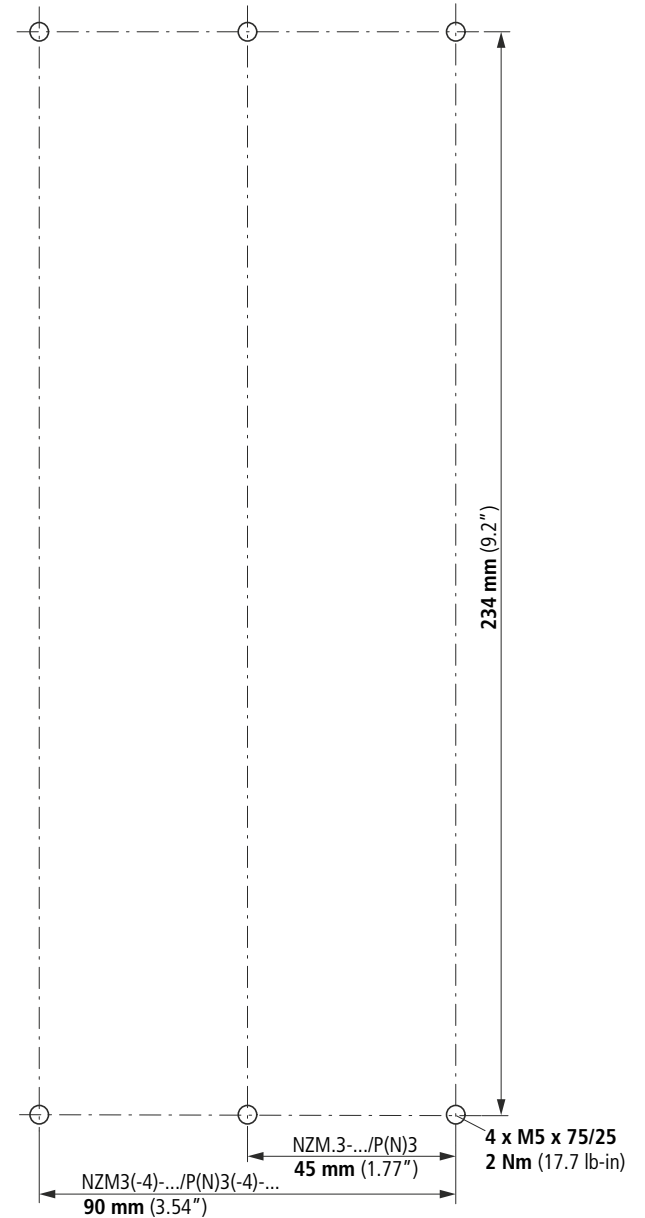
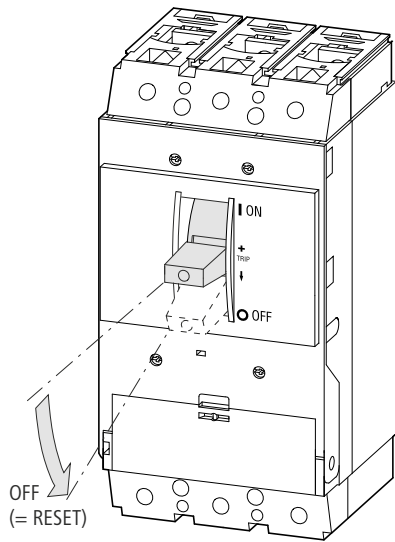

02/23 IL012100ZU

