



**(en) Electric current! Danger to life!**

Only skilled or instructed persons may carry out the following operations.

**(de)**

**Lebensgefahr durch elektrischen Strom!**

Nur Elektrofachkräfte und elektrotechnisch unterwiesene Personen dürfen die im Folgenden beschriebenen Arbeiten ausführen.

**(fr)**

**Tension électrique dangereuse !**

Seules les personnes qualifiées et averties doivent exécuter les travaux ci-après.

**(es)**

**¡Corriente eléctrica! ¡Peligro de muerte!**

El trabajo a continuación descrito debe ser realizado por personas cualificadas y advertidas.

**(it)**

**Tensione elettrica: Pericolo di morte!**

Solo persone abilitate e qualificate possono eseguire le operazioni di seguito riportate.

**(zh)**

**触电危险!**

只允许专业人员和受过专业训练的人员进行下列工作。

**(ru)**

**Электрический ток! Опасно для жизни!**

Только специалисты или проинструктированные лица могут выполнять следующие операции.

**(nl)**

**Levensgevaar door elektrische stroom!**

Uitsluitend deskundigen in elektriciteit en elektrotechnisch geïnstrueerde personen is het toegestaan, de navolgend beschreven werkzaamheden uit te voeren.

**(da)**

**Livsfare på grund af elektrisk strøm!**

Kun uddannede el-installatører og personer der er instruerede i elektrotekniske arbejdsopgaver, må udføre de nedenfor anførte arbejder.

**(el)**

**Προσοχή, κίνδυνος ηλεκτροπληξίας!**

Οι εργασίες που αναφέρονται στη συνέχεια θα πρέπει να εκτελούνται μόνο από ηλεκτρολόγους και ηλεκτροτεχνίτες.

**(pt)**

**Perigo de vida devido a corrente elétrica!**

Apenas electricistas e pessoas com formação eletrotécnica podem executar os trabalhos que a seguir se descrevem.

**(sv)**

**Livsfara genom elektrisk ström!**

Endast utbildade elektriker och personer som undervisats i elektroteknik får utföra de arbeten som beskrivs nedan.

**(fi)**

**Hengenvaarallinen jännite!**

Vain pätevät sähköasentajat ja opastusta saaneet henkilöt saavat suorittaa seuraavat työt.

**(cs)**

**Nebezpečí úrazu elektrickým proudem!**

Níže uvedené práce smějí provádět pouze osoby s elektrotechnickým vzděláním.

**(et)**

**Eluohhtlik! Elektrilöögiht!**

Järgnevalt kirjeldatud töid tohib teostada ainult elektriala spetsialist või elektrotehnilise instrueerimise läbinud personal.

**(hu)**

**Életveszély az elektromos áram révén!**

Csak elektromos szakemberek és elektrotechnikában képzett személyek végezhetik el a következőkben leírt munkákat.

**(lv)**

**Elektriskā strāva apdraud dzīvību!**

Tālāk aprakstītos darbus drīkst veikt tikai elektrospeciālisti un darbam ar elektrotehnikām iekārtām instruetās personas!

**(lt)**

**Pavojus gyvybei dėl elektros srovės!**

Tik elektrikai ir elektrotechnikos specialistai gali atlikti žemiau aprašytus darbus.

**(pl)**

**Porażenie prądem elektrycznym stanowi zagrożenie dla życia!**

Opisane poniżej prace mogą przeprowadzać tylko wykwalifikowani elektrycy oraz osoby odpowiedzialnie poinstruowane w zakresie elektrotechniki.

**(sl)**

**Življenjska nevarnost zaradi električnega toka!**

Spodaj opisana dela smejo izvajati samo elektrostrokovnjaki in elektrotehnično poučene osebe.

**(sk)**

**Nebezpečenstvo ohrozenia života elektrickým prúdom!**

Práce, ktoré sú nižšie opísané, smú vykonávať iba elektroodborníci a osoby s elektrotechnickým vzdelaním.

**(bg)**

**Опасност за живота от електрически ток!**

Операциите, описани в следващите раздели, могат да се извършват само от специалисти-електротехници и инструктиран електротехнически персонал.

**(ro)**

**Atenție! Pericol electric!**

Toate lucrările descrie trebuie efectuate numai de personal de specialitate calificat și de persoane cu cunoștințe profunde în electrotehnică.

**(hr)**

**Opasnost po život uslijed električne struje!**

Radove opisane u nastavku smiju obavljati samo stručni električari i osobe koje su prošle elektrotehničku obuku.

**(tr)**

**Elektrik akımı! Hayati tehlike!**

Aşağıdaki işlemleri yalnızca kalifiye veya eğitimli kişiler gerçekleştirebilir.

**(uk)**

**Електричний струм! Небезпечно для життя!**

Виконувати означені далі операції дозволяється тільки кваліфікованим особам, що пройшли інструктаж.

**(ar)**

**تحذير! تيار كهربائي! خطر موت! لا تتم أعمال الصيانة و التركيب إلا من قبل العاملين المدربين!**

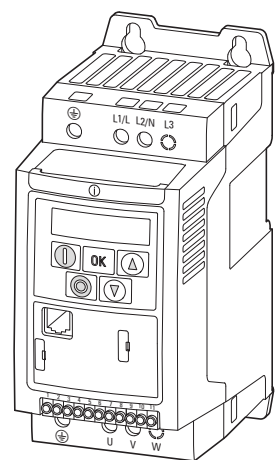

FS1, FS2, FS3  
IP20, NEMA 0



[Eaton.com/documentation](http://Eaton.com/documentation)

DC1-...-A20N DC1-...-A20CE1  
MN04020003Z... MN040022...  
MN04020004Z... MN040059...



[Eaton.com/EcoDesign-VFD](http://Eaton.com/EcoDesign-VFD)  
MZ040046EN



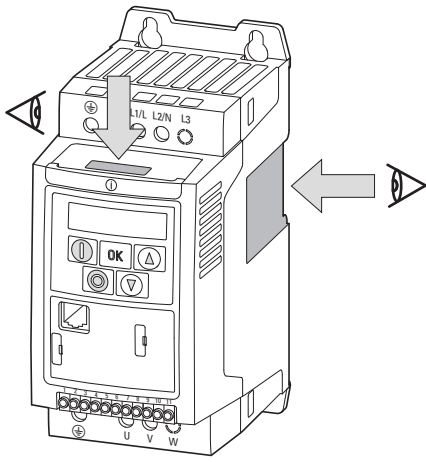

**DC1-x y zzz F N- A20 N**

- N = Standard
- CE1 = Coated Board, Enhanced, Version 1
- 20 = IP20, NEMA 0
- B = Brake chopper (DC+, BR)
- N = No Brake chopper
- F = EMC Filter (RFI)
- N = No EMC Filter
- $I_e$
- 2D2 = 2.2 A
- 024 = 24 A
- $U_{LN}$  (Mains), 50/60 Hz
- 1 = 110 V (110 - 115 V  $\pm 10\%$ )
- 2 = 230 V (200 - 240 V  $\pm 10\%$ )
- 4 = 400 V (380 - 480 V  $\pm 10\%$ )
- D = Doubler: 110 V (Mains)  $\rightarrow$  230 V (Motor)
- Mains  $\rightarrow$  Motor
- 1 = 1 AC  $\rightarrow$  3 AC
- 3 = 3 AC  $\rightarrow$  3 AC

**Mains (TN, TT)**

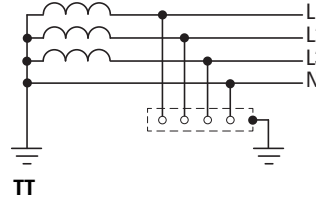
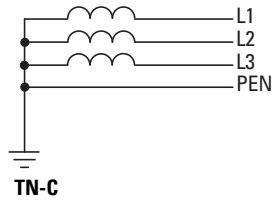
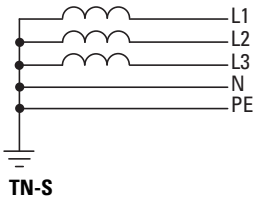

**DC1-12...**

Mains,  $U_{LN} = 1 \sim 200 - 240 \text{ V} \pm 10\%$

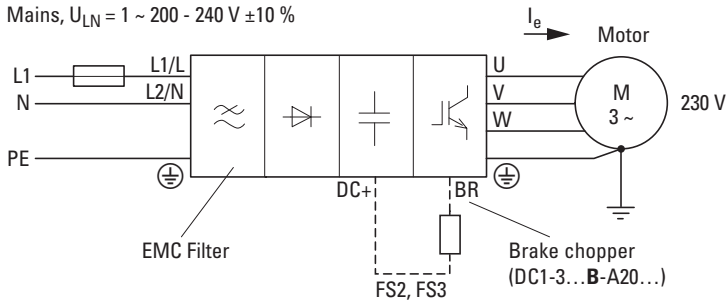

**DC1-32...**

Mains,  $U_{LN} = 3 \sim 200 - 240 \text{ V} \pm 10\%$

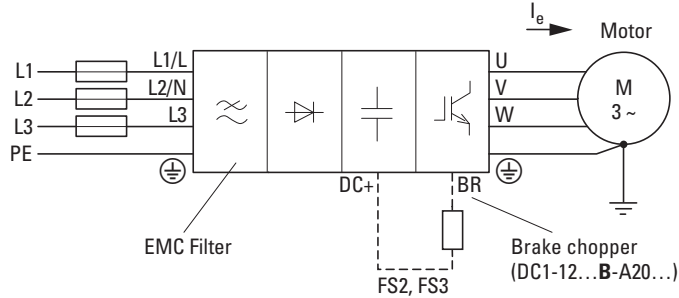

**DC1-34...**

Mains,  $U_{LN} = 3 \sim 380 - 480 \text{ V} \pm 10\%$

230 V ( $U_{LN} = 3 \sim 230 \text{ V}$ )  
 400 V ( $U_{LN} = 3 \sim 400 \text{ V}$ )  
 440 - 480 V ( $U_{LN} = 3 \sim 480 \text{ V}$ )

**DC1-1DzzzN...**

Mains,  $U_{LN} = 1 \sim 110 \text{ V}$

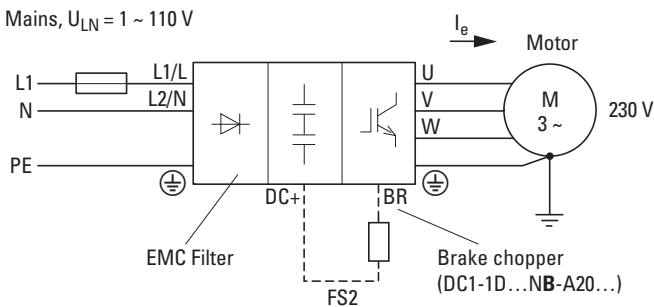

04/21 IL0402009Z

## Dimensions and weights

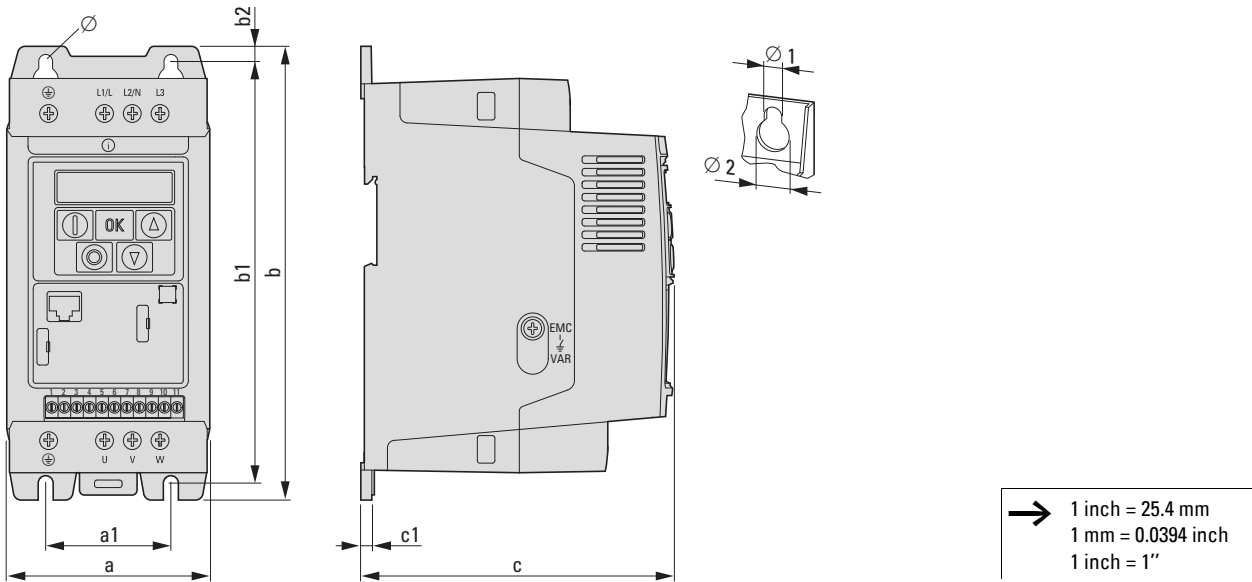

[mm (in)]

FS		a	a1	b	b1	b2	c	c1	Ø 1	Ø 2	 kg (lbs)
FS1	DC1-12...	81 (3.19)	50 (1.97)	184 (7.24)	170 (6.69)	7 (0.28)	124 (4.88)	4 (0.16)	6 (0.24)	12 (0.47)	1.1 (2.43)
	DC1-32...										
	DC1-34...										
	DC1-1D...										
FS2	DC1-12...	107 (4.21)	75 (2.95)	231 (9.09)	215 (8.46)	8 (0.31)	152 (5.98)	5 (0.2)	6 (0.24)	12 (0.47)	2.6 (5.73)
	DC1-32...										
	DC1-34...										
	DC1-1D...										
FS3	DC1-12...	129 (5.08)	100 (3.94)	273 (10.75)	255 (10.04)	8.5 (0.33)	175 (6.89)	5 (0.2)	6 (0.24)	12 (0.47)	4 (8.82)
	DC1-32...										
	DC1-34...										

04/21 IL0402009Z

## RJ45 (CANopen, Modbus RTU)

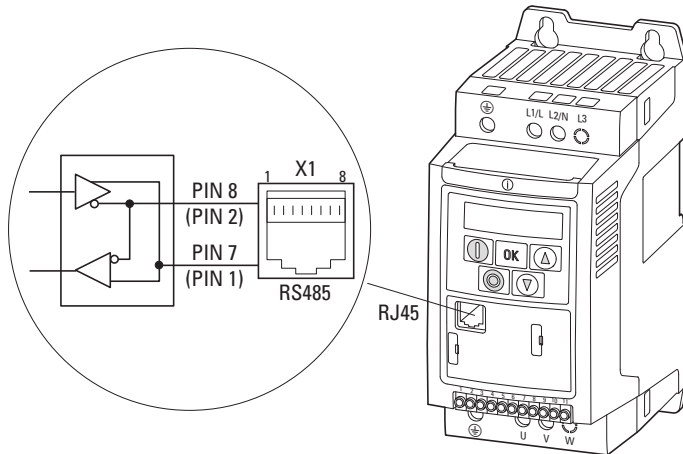

PIN 1	CANopen -
PIN 2	CANopen +
PIN 3	0 V
PIN 4	OP-Bus -
PIN 5	OP-Bus +
PIN 6	+24 V
PIN 7	Modbus RTU (A), RS485 -
PIN 8	Modbus RTU (B), RS485 +

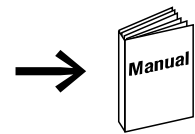

## Mounting on metal plate

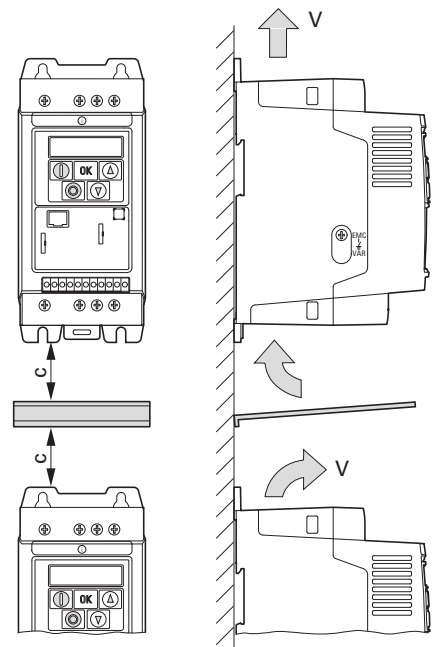
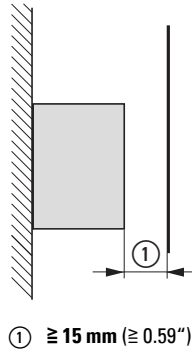
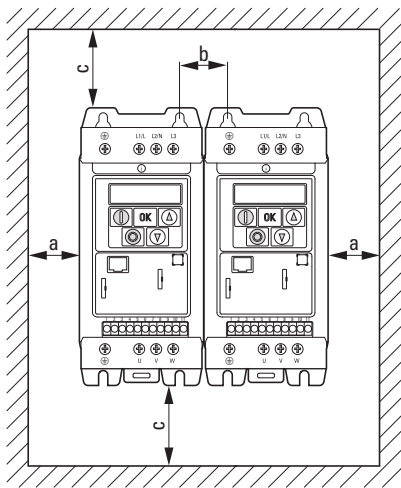
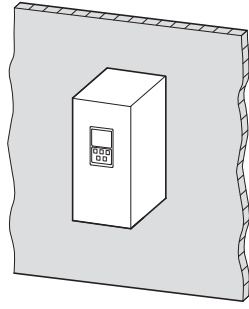
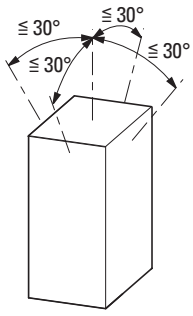

	a mm (in)	b mm (in)	c mm (in)	V m <sup>3</sup> /h (cfm)
FS1	50 (1.97)	46 (1.81)	75 (2.95)	18.69 (11)
FS2	50 (1.97)	46 (1.81)	75 (2.95)	18.69 (11)
FS3	50 (1.97)	52 (2.05)	100 (3.94)	101.94 (60)

## FS1, FS2

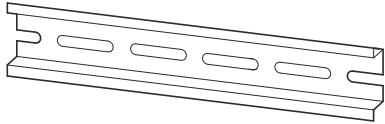

### IEC/EN 60715

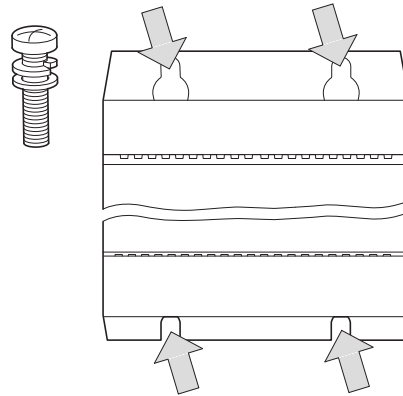
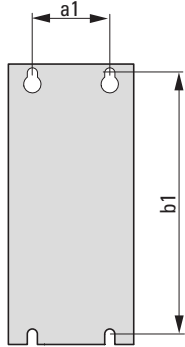
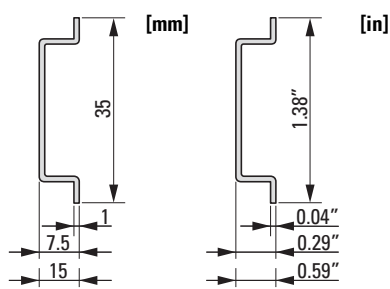

FS1, FS2:  $\oplus = 4 \times \text{M4}$   
1 Nm (8.85 lb-in)

FS3:  $\oplus = 4 \times \text{M5}$   
1.3 Nm (11.51 lb-in)

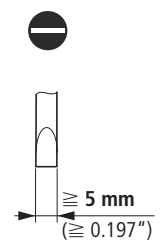
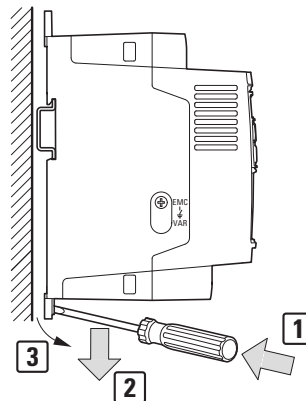
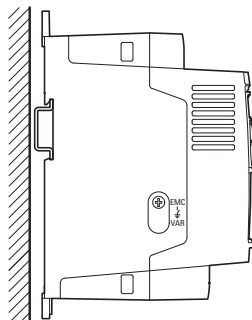
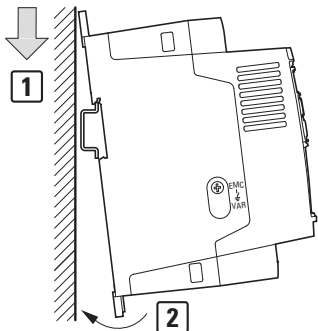

04/21 IL0402009Z

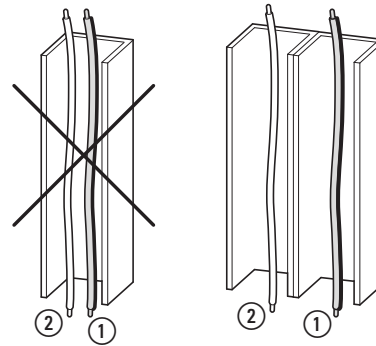
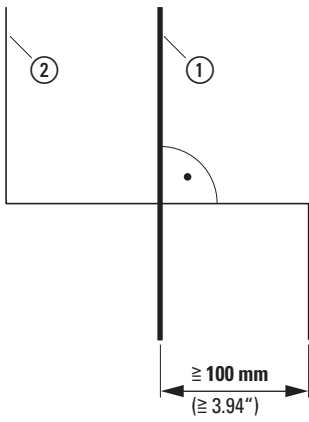
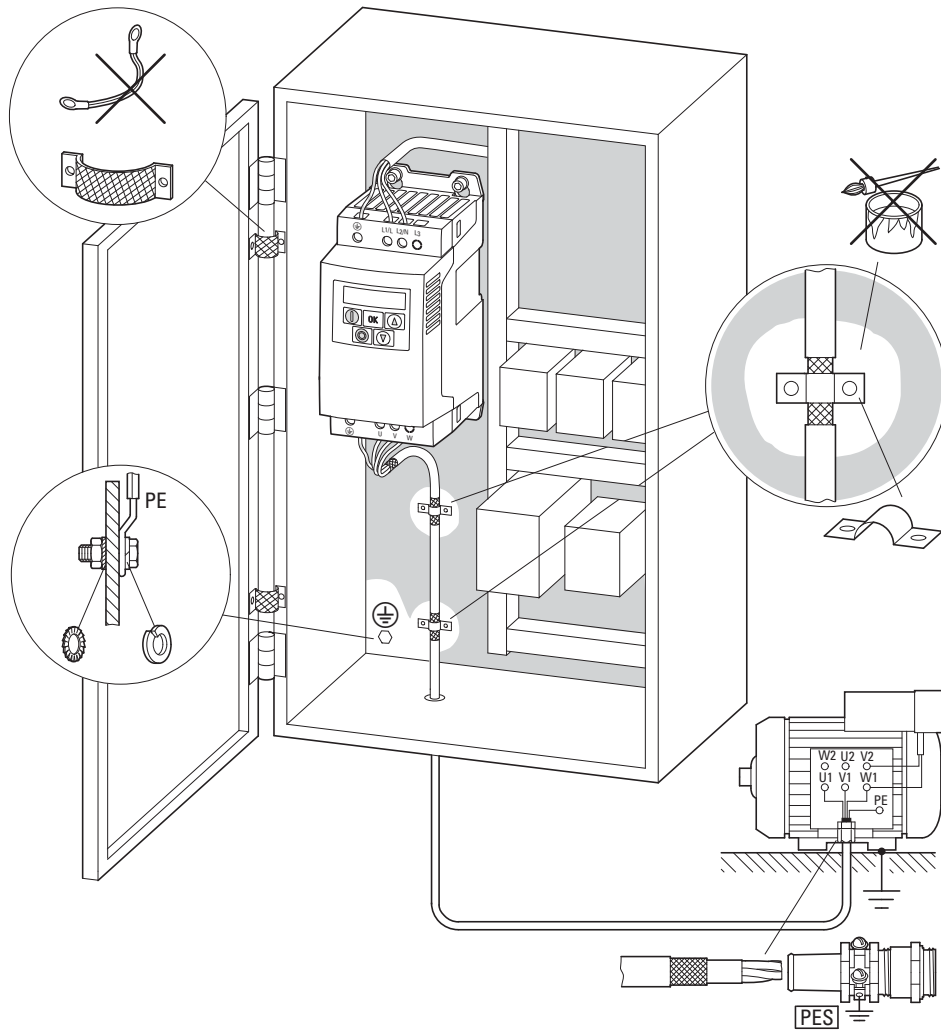

- ① Power: L1, L2, L3, N, PE, U, V, W, DC+, DC-, RB
- ② Control: 1, 2, ... n, Modbus, CANopen

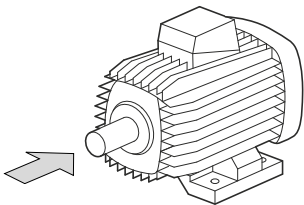

DC1	Motor (IEC)	(UL)
U	U1	T1
V	V1	T2
W	W1	T3

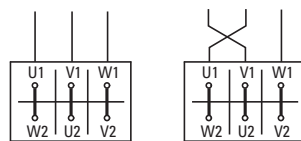

FWD

REV

230/400 V	3.2/1.9 A
0,75 KW	cosφ 0.79
1410 mi n <sup>-1</sup>	50 Hz

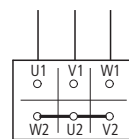
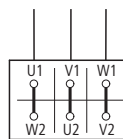

$U_{LN} = 230\text{ V}$   
 → DC1-12...  
 → DC1-32...  
 $U_{LN} = 115\text{ V}$   
 → DC1-1D...

$U_{LN} = 400\text{ V}$   
 → DC1-34...

(en) **NOTICE**

Connect only in voltage-free state!

(el) **ΕΠΙΓΡΥΠΝΗΣΗ**

Συνδέστε μόνο όταν δεν επικρατεί τάση!

(pl) **UWAGA**

Podłączać zawsze po uprzednim odłączeniu od zasilania elektrycznego!

(de) **ACHTUNG**

Nur im spannungsfreien Zustand anschließen!

(pt) **ADVERTÊNCIA**

Ligar apenas com a tensão desligada!

(sl) **POZOR**

Napravo priključite le, ko ni pod napetostjo!

(fr) **ATTENTION**

Raccordez l'appareil uniquement hors tension !

(sv) **OBSERVERA**

Får endast anslutas i spänningsfritt tillstånd!

(sk) **UPOZORNENIE**

Napájat' len v stave bez napätia!

(es) **CUIDADO**

¡Conectar únicamente en estado sin tensión!

(fi) **ILMOITUS**

Kytke vain jännitteettömässä tilassa!

(bg) **ПРЕДУПРЕЖДЕНИЕ**

Свързвайте само, когато уреда не е под напрежение!

(it) **AVVISO**

Collegare solo in assenza di tensione!

(cs) **UPOZORNĚNÍ**

Připojujte jen při zcela odpojeném napájení!

(ro) **ATENȚIE**

Conectați doar când aparatul nu se află sub tensiune!

(zh) **注意**

必須在断电状态下进行连接!

(et) **TÄHELEPANU**

Ühendada ainult pingevabas olekus!

(hr) **POZOR**

Priključite samo u beznaponskom stanju!

(ru) **ВНИМАНИЕ**

Подключать только в обесточенном состоянии!

(hu) **FIGYELEM**

Csak feszültségmentes állapotban csatlakoztassa!

(tr) **BİLDİRİM**

Sadece gerilim sıfırken bağlayın!

(nl) **OPGELET**

Alleen in spanningsloze toestand aansluiten!

(lv) **UZMANĪBU**

Pieslēgt tikai tad, kad nenotiek sprieguma padeve!

(uk) **ПОВІДОМЛЕННЯ**

Підключати лише за відсутності напруги!

(da) **VIGTIGT**

Må kun tilsluttes i spændingsfri tilstand!

(lt) **DĖMESIO**

Prijungti tik tada, kai išjungta įtampa!

(ar) **ملاحظة**

التوصيل فقط في حال عدم الفولتية!

**Mains 1 ~**

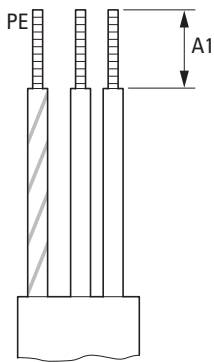

**Mains 3 ~**

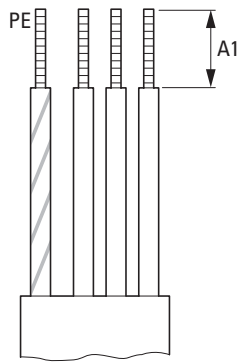

**Motor**

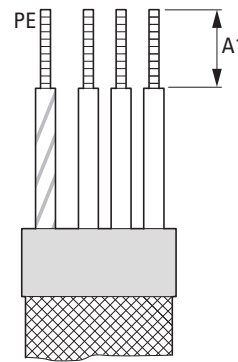

**Brake Resistor**

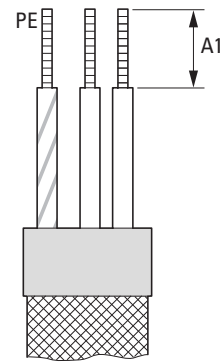

**FS1**

A1 = 8 mm (0.31")

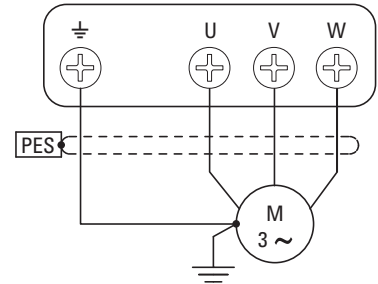
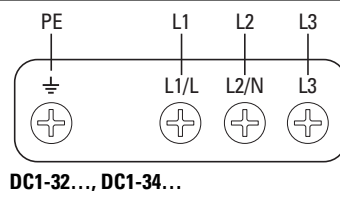
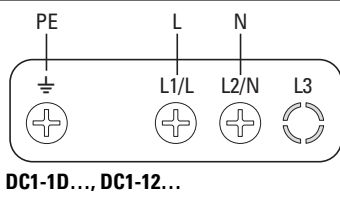

**FS2**

**FS3**

A1 = 10 mm (0.39")

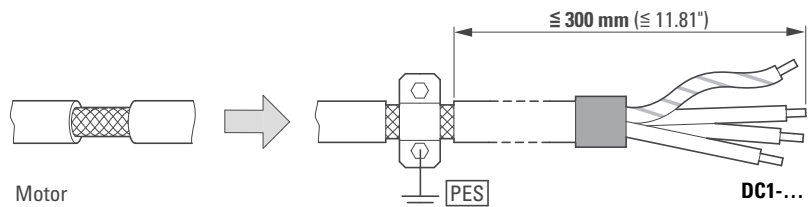
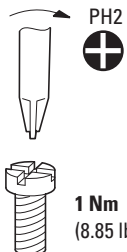
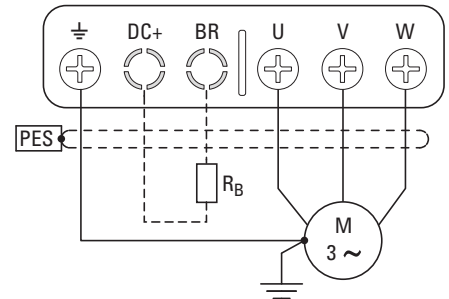
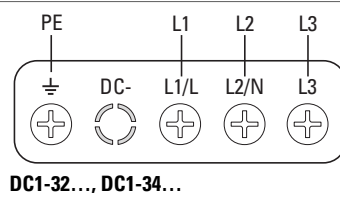
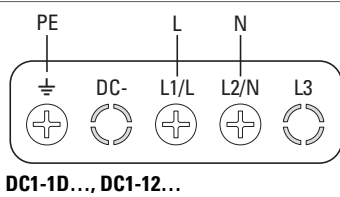

04/21 IL0402009Z

**DC1-1DxxxN...**

**DC1-12...**

**DC1-32...  
DC1-34...**

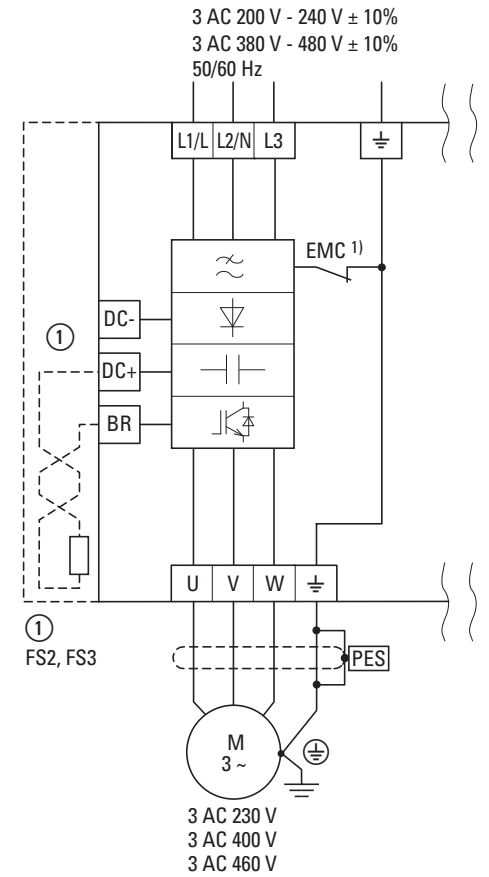
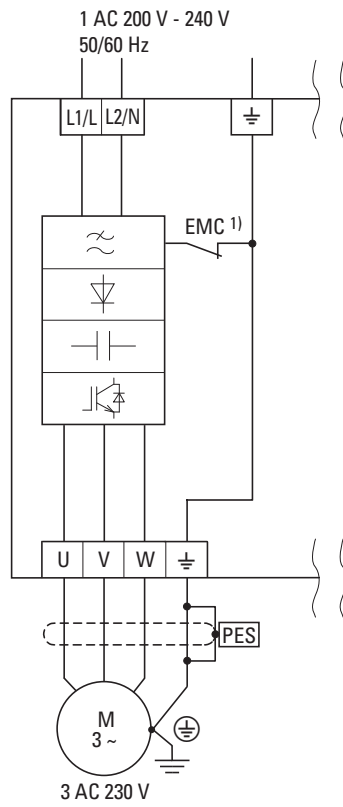
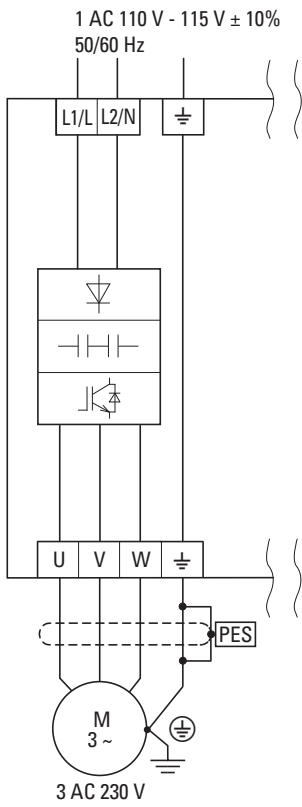

04/21 IL04020009Z

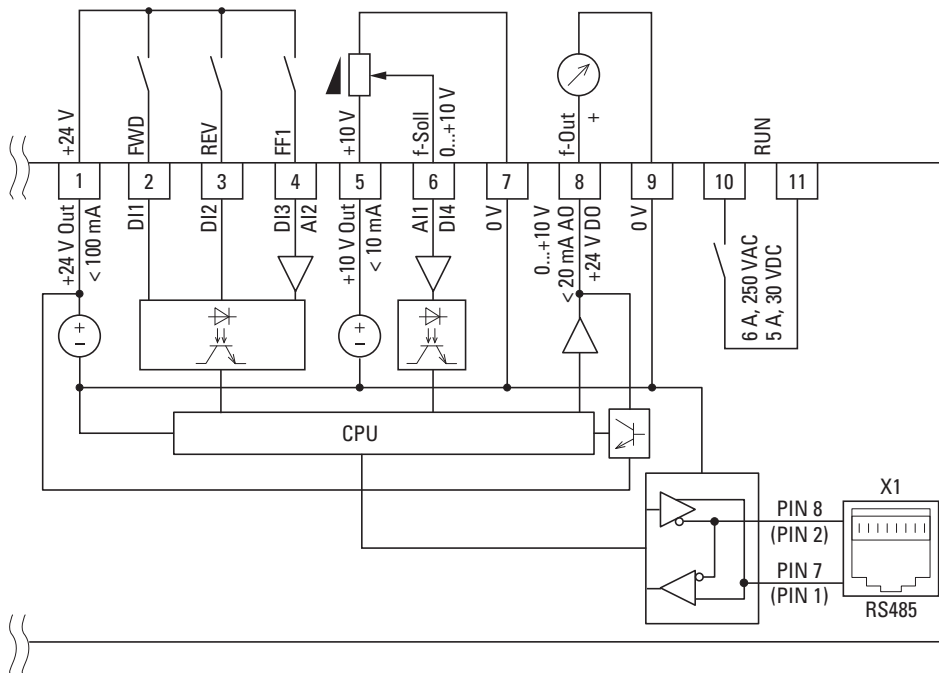
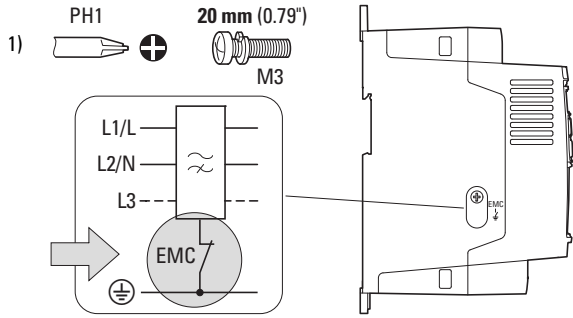

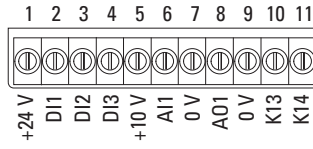
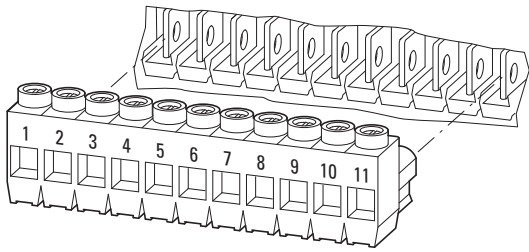

mm <sup>2</sup>	mm <sup>2</sup>	AWG	mm	in	M3 Nm	lb-in	mm
0.25 - 0.5	0.14 - 1.5	26 - 16	5	0.2	0.5	4.43	0.4 x 2.5

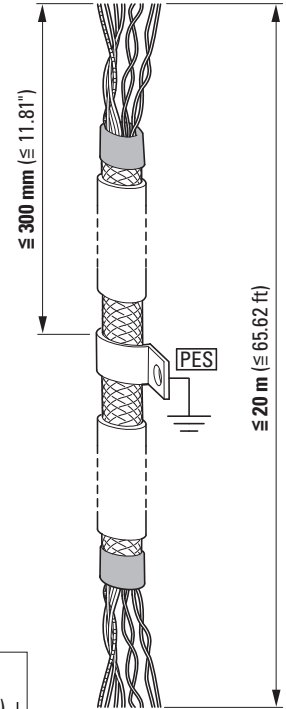
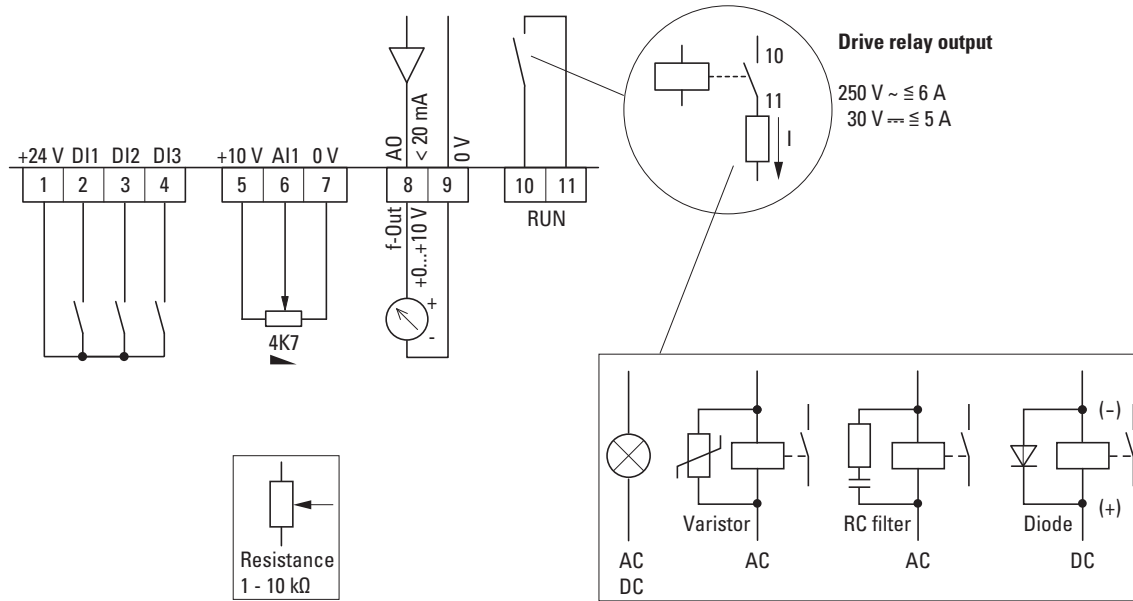

04/21 IL04020009Z

### Thermistor

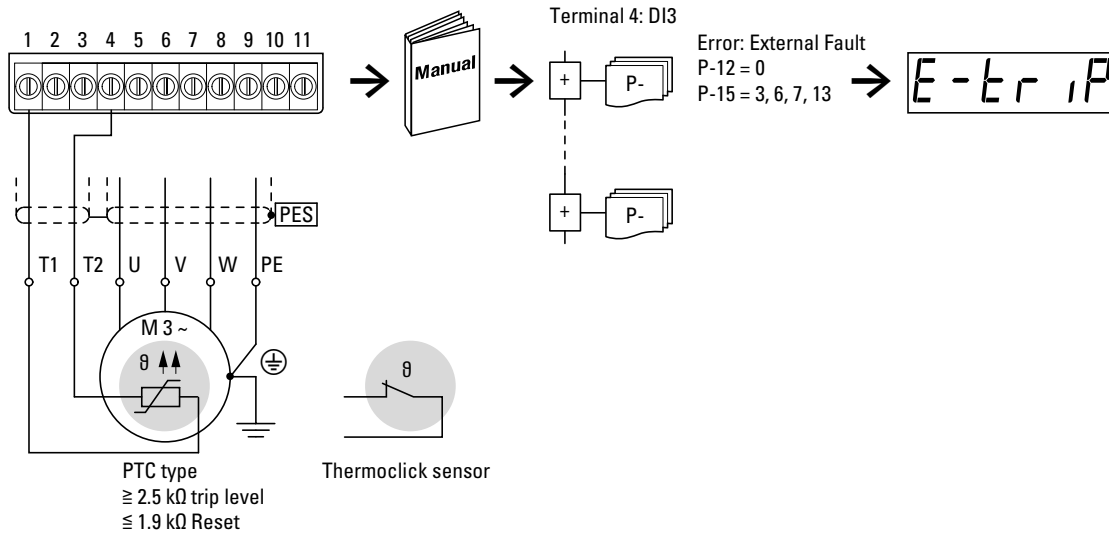



**Mains**

1 ~ 200 V - 240 V ±10 %, 50/60 Hz

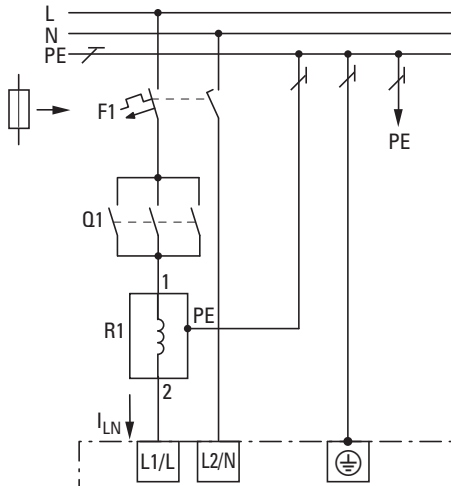

**Mains**

3 ~ 200 V - 240 V ±10 %, 50/60 Hz  
3 ~ 380 V - 480 V ±10 %, 50/60 Hz

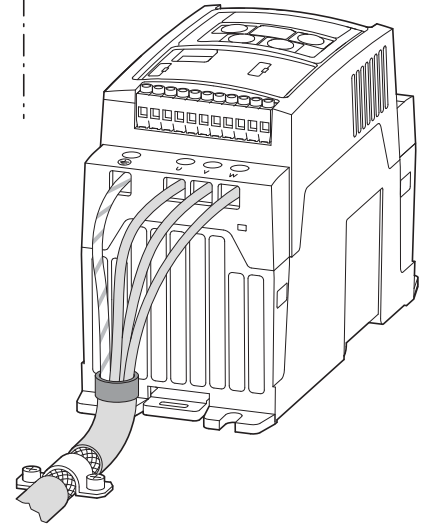
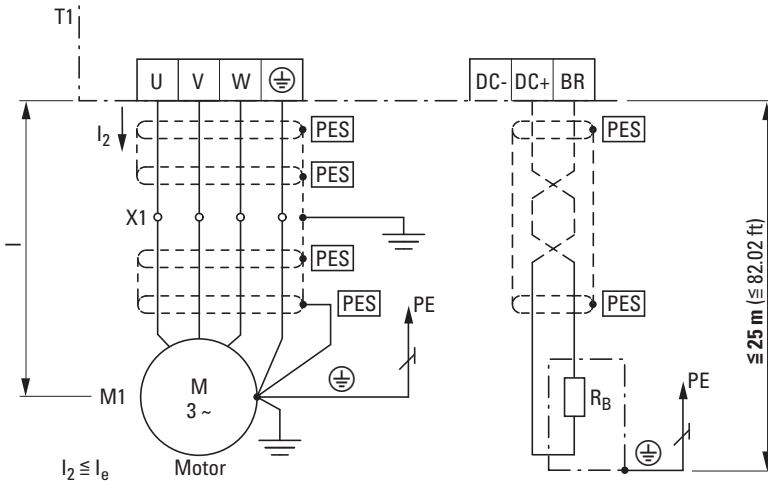
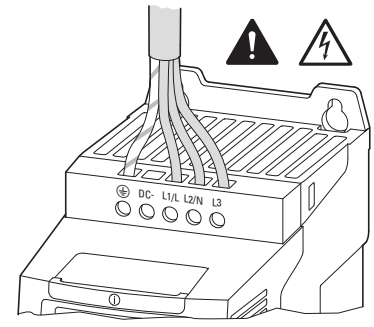
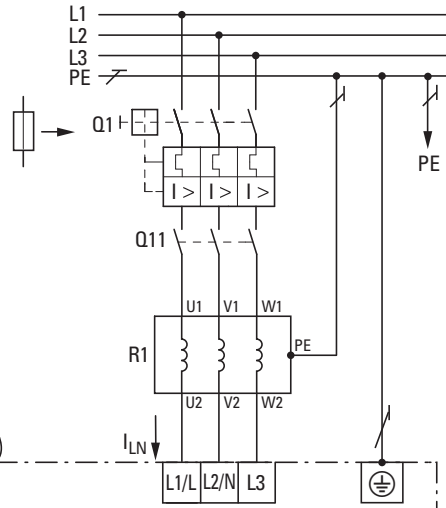

04/21 IL04020009Z

Typ	Frame Size	I <sub>LN</sub>	F1/Q1 MCB (type B)	Mains		I <sub>2</sub>	Motor		P	R <sub>B</sub>	R <sub>B</sub>		
				mm <sup>2</sup>	AWG		mm <sup>2</sup>	AWG			Ω	mm <sup>2</sup>	AWG
DC1-12011...	FS2	19.2	25	4	10	10.5	1.5	16	2.2	3	50	1.5	16
DC1-12015...	FS3	29.2	40	6	8	15.3	2.5	14	4	5	25	1.5	16
DC1-122D3...	FS1	3.7	10 (6)	1.5	16	2.3	1.5	16	0.37	0.5	-	-	-
DC1-124D3...	FS1, FS2	7.5	10	1.5	16	4.3	1.5	16	0.75	1	100	1.5	16
DC1-127D0...	FS1, FS2	12.9	16 (17.5)	2.5	14	7	1.5	16	1.5	2	100	1.5	16
DC1-1D2D3...	FS1	7.8	10	2.5	14	2.3	2.5	14	0.37	0.5	-	-	-
DC1-1D4D3...	FS1	15.8	25	4	10	4.3	4	12	0.75	1	-	-	-
DC1-1D5D8...	FS2	21.9	32 (30)	6	8	5.8	6	10	1.1	1.5	100	1.5	16
DC1-32018...	FS3	20.9	32 (30)	6	8	18	2.5	14	4	5	25	1.5	16
DC1-32024...	FS3	26.4	40 (35)	6	8	24	6	10	5.5	7.5	20	1.5	16
DC1-322D3...	FS1	3.4	6	1.5	16	2.3	1.5	16	0.37	0.5	-	-	-
DC1-324D3...	FS1, FS2	5.6	10	1.5	16	4.3	1.5	16	0.75	1	100	1.5	16
DC1-327D0...	FS1, FS2	9.5	16 (15)	1.5	16	7	1.5	16	1.5	2	100	1.5	16
DC1-327D0...	FS2	12.1	16 (17.5)	2.5	14	10.5	1.5	16	2.2	3	50	1.5	16
DC1-34014...	FS3	17.2	25	4	10	14	2.5	14	5.5	7.5	100	2.5	14
DC1-34018...	FS3	21.2	32 (35)	6	8	18	2.5	14	7.5	10	80	2.5	14
DC1-34024...	FS3	27.5	40 (35)	6	8	24	6	10	11	15	50	2.5	14
DC1-342D2...	FS1, FS2	3.5	6	1.5	16	2.2	1.5	16	0.75	1	250	1.5	16
DC1-344D1...	FS1, FS2	5.6	10	1.5	16	4.1	1.5	16	1.5	2	250	1.5	16
DC1-345D8...	FS2	7.5	16 (10)	1.5	16	5.8	1.5	16	2.2	3	200	1.5	16
DC1-349D5...	FS2	11.5	16 (15)	2.5	14	9.5	1.5	16	4	5	120	1.5	16

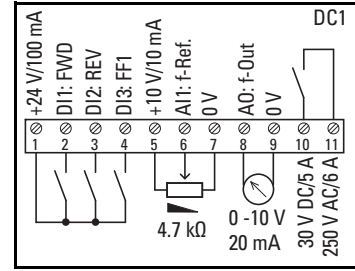
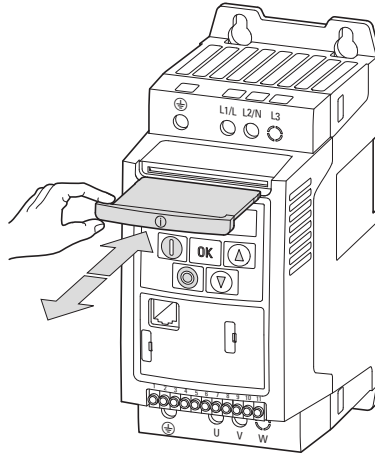
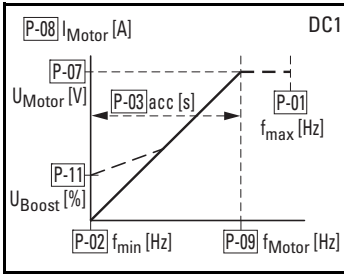

Motor protection

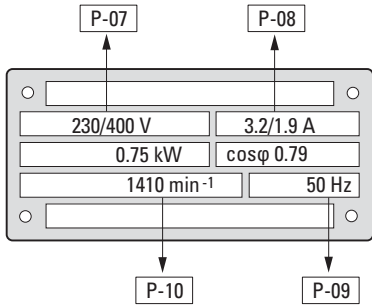

Example: DC1-342D3...

34 → 3~400 V (P-07)  
2D3 → 2.3 A (P-08)

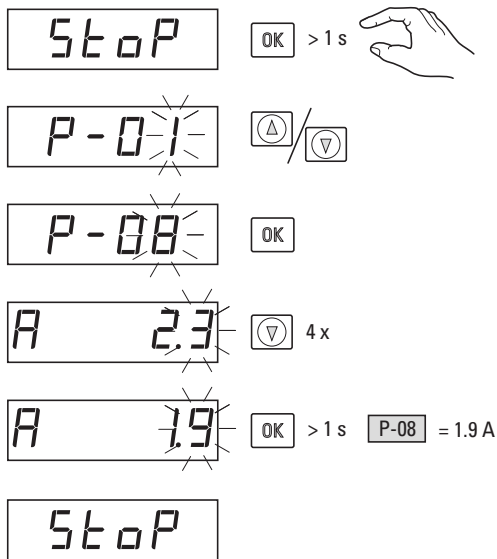

Keypad Control

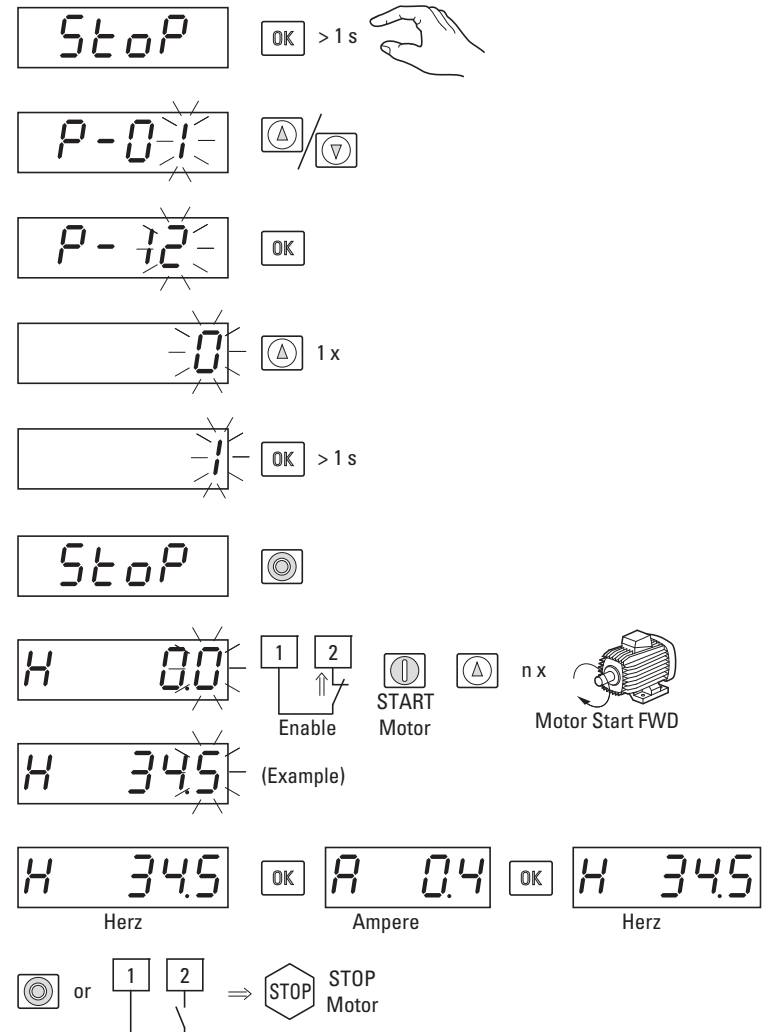
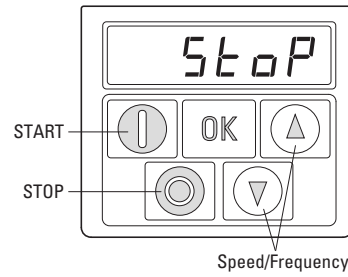

04/21 IL04020009Z



### en CAUTION

In the territory of the EU Directive the frequency-controlled devices and their accessories must be taken into operation only when the machine has been determined to fulfill the protection requirements of Machinery Directive 2006/42/EC.

Ensure EMC-compliant installation. Lay control and communication cables spatially separated from the motor cable. Ensure a large contact area connection between [PES](#) cable screen and PE.

### de VORSICHT

Im Geltungsbereich der EG-Richtlinien dürfen die frequenzgesteuerten Geräte und deren Zubehör nur dann in Betrieb genommen werden, wenn festgestellt wird, dass die Maschine die Schutzanforderungen der Maschinenrichtlinie 2006/42/EG erfüllt.

EMV-gerechter Aufbau. Steuer- und Netzleitungen räumlich getrennt von der Motorleitung verlegen. [PES](#) Leitungsschirm großflächig mit PE verbinden.

### fr AVERTISSEMENT

En application des directives européennes, les convertisseurs de fréquence et leurs accessoires ne doivent être mis en service que s'il a été vérifié que la machine répond aux exigences de la directive machines 2006/42/CE.

Montage conforme aux règles de la CEM. Eloigner les câbles de commande et de réseau des câbles puissance. Relier le blindage [PES](#) au PE en assurant de grandes surfaces de contact.

### es ATENCIÓN

En el campo de aplicación de la normativa CE, los dispositivos controlados por frecuencia y sus correspondientes accesorios sólo deberán ponerse en marcha cuando se asegure que la máquina cumple con las exigencias de seguridad de la normativa de máquinas 2006/42/CE. El montaje debe cumplir CEM. Los cables de mando y de conexión a red se deben instalar independientemente del cable de conexión al motor. El cable apantallado [PES](#) se debe conectar a masa utilizando una amplia superficie de contacto.

### it ATTENZIONE

Nel campo di validità delle direttive CE, gli apparecchi a controllo di frequenza e i loro accessori possono essere messi in esercizio soltanto se si verifica che la macchina soddisfa i requisiti di sicurezza della direttiva macchine 2006/42/CE

Montaggio secondo CEM. Disporre i cavi comandi e di alimentazione separati dal cavo del motore. Collegare lo schermo del cavo [PES](#) con PE con un'ampia superficie.

### zh 小心

根据欧盟设备一致性规范，安装频率控制设备及其配件时，应确保设备满足机器规范 2006/42/EG 中关于设备保护的要求。

[PES](#) 按照电磁兼容规范正确安装。应将控制电缆和电源电缆与电机电缆分开。大面积采用 PE 包裹电缆。

### ru ОСТОРОЖНО

В сфере действия директив ЕС устройства с частотным управлением и их оснащение должны вводиться в эксплуатацию только в том случае, если установлено, что данное оборудование соответствует требованиям по защите Директивы о машинном оборудовании 2006/42/ЕС.

Сборка соответственно электромагнитной совместимости. Линии управления и электросети прокладывать в пространственном отношении отдельно от линии двигателя. [PES](#) силовой экран соединять с PE по большой площади.

### nl VOORZICHTIG

Binnen het geldigheidsgebied van de EC-richtlijnen mogen de frequentieregelde apparaten en de toebehoren daarvan alleen in bedrijf worden genomen, wanneer wordt vastgesteld, dat de machine aan de veiligheidsvoorschriften van de machinerichtlijn 2006/42/EG voldoet.

EMC-conforme constructie. Besturings- en netkabels ruimtelijk gescheiden van de motorkabel leggen. [PES](#) Kabelafscherming over groot oppervlak met PE verbinden.

### da FORSIGTIG

I det område, hvor EF-direktiverne er gældende, må det frekvensstyrte udstyr og dets tilbehør kun tages i anvendelse, hvis det konstateres, at maskinen opfylder beskyttelseskravene i maskindirektivet 2006/42/EF.

EMC-korrekt installation. Træk styre- og netledninger rumligt adskilt fra motorledningen. [PES](#) Sørg for en stor kontaktflede mellem PES ledningsafskærmning og PE.

### el ΠΡΟΣΟΧΗ

Στο πεδίο εφαρμογής των οδηγιών της ΕΚ, οι ελεγχόμενες μέσω συχνότητας συσκευές και τα παρελκόμενά τους επιτρέπεται να τίθενται σε λειτουργία μόνο εφόσον διαπιστωθεί ότι το μηχανήμα πληροί τις απαιτήσεις προστασίας της οδηγίας της ΕΚ για τα μηχανήματα 2006/42/ΕΚ. Κατασκευή σύμφωνα με τις απαιτήσεις ΗΜΣ. Εγκλιση στους αγωγούς ελέγχου και δικτύου ανεξάρτητα από τον αγωγό του κινητήρα. [PES](#) Συνδέστε τη θωράκιση των αγωγών σε μεγάλη επιφάνεια με τη γείωση.

### pt CUIDADO

No âmbito das directivas da CE, os aparelhos comandados por frequência e os respectivos acessórios só podem ser postos em operação se for comprovado que a máquina atende às exigências de protecção da directiva de máquinas 2006/42/CE.

Estrutura com compatibilidade electromagnética. Dispor os fios de comando e de rede separados do fio do motor. Ligar uma área grande da blindagem do cabo [PES](#) com o PE.

### sv FÖRSIKTIG

I giltighetsområdet för EG-direktiven får de frekvensstyrda apparaterna och deras tillbehör endast tagas i drift när man fastställt att maskinen uppfyller skyddskraven i maskindirektiv 2006/42/EG.

EMC-anpassad uppbyggnad. Styr- och nätledningar dras avskilda från motorledningarna. [PES](#) Förbind ledningsskärm över ett brett område med PE.

### fi HUOMIO

EU-direktiivien voimassaoloalueella taajuusohjatut laitteet ja niiden varusteet saa ottaa käyttöön vain silloin, kun todetaan, että kone täyttää konedirektiivin 2006/42/EY suojausvaatimukset.

EMC-mukainen rakenne. Ohjauksen- ja verkkojohtodot on asennettava tilalouetteisesti erotettuina. Johdonsuojat on liitettävä laajasti maadoitukseen [PES](#).

### cs POZOR

V rozsahu platnosti směrnice ES smí být frekvenčně řízené přístroje a jejich příslušenství uvedeny do provozu jedině tehdy, pokud je zjištěno, že stroj splňuje požadavky ochrany stanovené směrnici 2006/42/ES o strojních zařízeních.

Nástavba odpovídající směrnici EMC. Řídící a síťová vedení pokládejte prostorově oddělená od vedení motoru. [PES](#) Stínění vedení spojte vcelkoplošně s PE.

### et ETTEVAATUST

EU-direktiivi kehtivuspiirkonnas võib sagedusjuhitavaid seadmeid ja nende lisaseadmeid kasutusele võtta ainult siis, kui on kindlaks tehtud, et masin vastab masinadirektiivi 2006/42/EÜ kaitsenõuetele.

Elektromagnetilise ühilduvusele vastav ehitus. Juhtimis- ja võrgukaablid paigaldada mootori toitekaablist ruumiliselt eraldatuna. [PES](#) Kaabli kaitsekraan ühendada ulatuslikult talitlusmaandusega.

### hu VIGYÁZAT

Az EK irányelvek hatályosságai területén a frekvenciavezérelt készülékeket és azok tartozékait csak akkor szabad üzembe helyezni, ha megállapítást nyert, hogy a gép megfelel a gépek biztonságáról szóló, 2006/42/EK számú irányelv biztonságási követelményeinek.

Elektromágnesesen összeférhető kivitelű biztosítson. A motorvezetékektől térben elkülönítve vezesse vezérlő és hálózati vezetékeket. [PES](#) Nagy felületen csatlakoztassa a védőföldeléshez a vezetéknyélkolást.

### lv IEVĒRŅĀT PIESARDZĪBU

Valstīs, kurās ir spēkā EK direktīvas, ierīču ar frekvenču vadību un to piederumu ekspluatāciju drīkst sākt tikai tad, ja ir konstatēta iekārtas atbilstība Mašīnu direktīvai 2006/42/EK ietvertajām aizsardzības prasībām.

EMS atbilstoša uzbūve. Vadības un tīkla kabelus izvietot atsevišķi no motora kabeļa. [PES](#) Vada ekrānu plašā virsmā savienot ar PE.

### lt ATSARGIAI

EB direktyvų taikymo srityje dažniniu būdu valdomos įrenginius ir jų priedus leidžiama pradėti naudoti tik tada, kai nustatoma, kad įrenginys atitinka Mašinų direktyvos 2006/42/EB keliamus apsaugos reikalavimus.

Montažas turi atitikti EMS reikalavimus. Valdymo ir duomenų tinklo kabelius išdėstyti atokiai nuo variklio kabelio. [PES](#) Kabelio ekraną dideliu paviršiumi sujungti su žeminiu.

### pl OSTROŻNIE

Na obszarze obowiązywania dyrektyw WE urzędzenia sterowane częstotliwościami wolno wprowadzać do eksploatacji tylko wtedy, gdy zostanie stwierdzone, że maszyna spełnia wymagania ochronne dyrektywy maszynowej 2006/42/WE.

Konstrukcja zgodna z dyrektywą w sprawie kompatybilności elektromagnetycznej (EMC). Przewody sterowania i zasilania elektrycznego należy układać oddzielnie od przewodu silnika. [PES](#) Ekranowanie połączyć z przewodem uziemiającym na większej powierzchni.

### sl PREVIDNO

Na območju veljavnosti direktiv ES je zagon frekvenčno krmiljenih naprav in njihovega pribora dovoljen le tedaj, ko je bilo ugotovljeno, da stroj ustreza varnostnim zahtevam Direktive o strojih 2006/42/ES.

Montaža v skladu z EMZ. Krmilne in omrežne vodnike napeljte ločeno od vodnikov motorja. [PES](#) Oklep vodnika na veliki površini povežite z zaščitnim vodnikom.

### sk VÝSTRAHA

V krajinách, ktoré spadajú pod pôsobnosť smerníc ES smú byť rádiové ovládané zariadenia a ich príslušenstvo uvedené do prevádzky len ak je zabezpečené, že stroj spĺňa ochranné ustanovenia smernice č. 2006/42/ESS o strojových zariadeniach.

Montáž v súlade s požiadavkami elektromagnetickej kompatibility. Ovládacie a sieťové vedenia uložte v priestore oddelene od vedenia motora. [PES](#) Zabezpečte veľkú kontaktnú plochu medzi káblovým tienením a PE.

### bg ВНИМАНИЕ

В сферата на действие на изискванията на ЕС устройствата с честотно управление и техните допълнителни устройства могат да бъдат приведени в употреба, само ако се установи, че оборудването съответства на изискванията за безопасност на машинно оборудване спрямо 2006/42/EO.

Монтаж с електромагнитна съвместимост. Полагане на контролните и мрежови проводници пространствено отделно от проводника на двигателя. [PES](#) Осигурете по-голяма контактна площ между силовия екран и PE.

### ro PRECAUTJE

În cadrul sferei de aplicare a directivei UE dispozitivele controlate prin frecvență și accesoriile acestora au voie să fie puse în funcțiune doar dacă se stabilește că aparatul îndeplinește cerințele Directivei 2006/42/CE privind mașinile.

Montajul trebuie să fie compatibil EMC. Poziționati cablurile de control și de rețea la distanță de cablul motorului. [PES](#) Asigurați o suprafață de contact mare între izolația cablului și PE.

### hr OPREZ

U području valjanosti Direktiva EZ frekvencijski upravljani uređaji i njihov pribor smiju se puštati u rad samo ako se utvrdi da stroj ispunjava zahtjeve za zaštitom iz Direktive o strojevima 2006/42/EZ.

Konstrukcija u skladu s EMC-om. Upravljački i mrežni vodovi prostorno položeni odvojeno od voda motora. [PES](#) zaslon kabela povezan PE-om na velikoj površini.

### tr DİKKAT

AB Direktifi dahilinde, frekans kontrollü cihazlar ve aksesuarları, yalnızca makinelerin 2006/42/EC Makina Emniyet Direktifi koruma şartlarını karşıladığı belirlendiğinde kullanılmalıdır.

EMC uyumlu kurulum sağlayın. Kontrol ve iletişim kablolarını uzamsal olarak motor kablosundan ayrı koyun. [PES](#) kablo ekranı ile PE arasında geniş bir temas alanı bağlantısı olmasını sağlayın.

### uk ОБЕРЕЖНО!

На території, на яку поширюється дія Директив ЄС, пристрої з частотним регулюванням та їхні приналежності можуть вводитися в експлуатацію лише в разі визнання їх такими, що відповідають вимогам до захисту, викладеним у Директиві про машинне обладнання 2006/42/EC.

Переконайтеся в тому, що встановлена система відповідає вимогам до EMC. Кабелі керування та зв'язку мають бути просторово відокремлені від кабелю електродвигуна. Зabezпечте достатню контактну поверхню між екраном кабелю [PES](#) та PE.

### ar احذر

في المنطقة التي تخضع لتوجيه الاتحاد الأوروبي، يجب ألا يتم تشغيل الأجهزة وملحقاتها التي يتم التحكم فيها بواسطة التردد إلا بعد التأكد من أنها تستوفي متطلبات حماية توجيه الماكينات 2006/42/EC.

ع كابلانص. ا لتوافق الكهرومغناطيسياحرص على أن يكون التركيب مطابقاً عن كابل المحرك. تأكد من وجودالتحكم والاتصال بشكل منفصل مكاني وPE ومنظفة تلامس كبيرة بين شاشة كبل

# Additional Information for UL<sup>®</sup> Approved Installations

→ Refer to Manual MN04020003Z-EN and MN040023EN.

DC1 is designed to meet the UL requirements. In order to ensure full compliance, the following must be fully observed.

## Input Power Supply Requirements

<b>Supply Voltage</b>	DC1-12...	200 - 240 RMS Volts for 230 Volt rated units, ±10 % variation allowed. 240 Volt RMS Maximum		
	DC1-34...	380 - 480 Volts for 400 Volt rated units, ±10 % variation allowed, Maximum 500 Volts RMS		
<b>Imbalance</b>	Maximum 3 % voltage variation between phase – phase voltages allowed All DC1 units have phase imbalance monitoring. A phase imbalance of > 3 % will result in the drive tripping. For input supplies which have supply imbalance greater than 3 % Eaton Drives recommends the installation of input line reactors.			
<b>Frequency</b>	50 - 60 Hz ±5 % Variation			
<b>Short Circuit Capacity</b>	<b>Voltage Rating</b>	<b>Min. kW (HP)</b>	<b>Max. kW (HP)</b>	<b>Maximum supply short-circuit current</b>
	230 V	7.5 (10)	11 (15)	100 kA rms (AC)
	400/460 V	15 (20)	22 (30)	100 kA rms (AC)
All the drives in the above table are suitable for use on a circuit capable of delivering not more than the above specified maximum short-circuit Amperes symmetrical with the specified maximum supply voltage.				

## Incoming power supply connection

- For 1 phase supply, power should be connected to L1/2 and L2/N.
- For 3 phase supplies, power should be connected to L1, L2, and L3. Phase sequence is not important.
- For compliance with CE and C Tick EMC requirements, a symmetrical shielded cable is recommended.
- A fixed installation is required according to IEC61800-5-1 with a suitable disconnecting device installed between the DC1 and the AC Power Source. The disconnecting device must conform to the local safety code/regulations (e. g. within Europe, EN60204-1, Safety of machinery).
- The cables should be dimensioned according to any local codes or regulations. Guideline dimensions are given on Seite 9.
- Suitable fuses to provide wiring protection of the input power cable should be installed in the incoming supply line, according to the data on Seite 9. The fuses must comply with any local codes or regulations in place. In general, type gG (IEC 60269) or UL Class CC or Class J fuses are suitable; however in some cases type aR fuses may be required. The operating time of the fuses must be below 0.5 seconds. The max. voltage rating for fuses is 600 V.
- Where allowed by local regulations, suitably dimensioned type B MCB circuit breakers of equivalent rating may be utilised in place of fuses, providing that the clearing capacity is sufficient for the installation. The max. voltage rating for breakers is 480 V.
- When the power supply is removed from the drive, a minimum of 30 seconds should be allowed before re-applying the power. A minimum of 5 minutes should be allowed before removing the terminal covers or connection.
- The maximum permissible short circuit current at the DC1 Power terminals as defined in IEC60439-1 is 100 kA.
- An optional Input Choke is recommended to be installed in the supply line for drives where any of the following conditions occur:
  - The incoming supply impedance is low or the fault level/short circuit current is high.
  - The supply is prone to dips or brown outs.
  - An imbalance exists on the supply (3 phase drives).
- In all other installations, an input choke is recommended to ensure protection of the drive against power supply faults.

## All DC1 units are intended for indoor installation within controlled environments which meet the condition limits.

<b>Ambient temperature range</b>	<b>Operational</b>	-10 °C to 50 °C (14 °F to 122 °F), to 60 °C (140 °F) with derating
	<b>Storage and Transportation</b>	-40 °C to 60 °C (-40 °F to 140 °F)
<b>Max. altitude for rated operation</b>	1000 m (Refer to Manual for Derating for Altitude Information). Installation above 2000 m is not UL approved.	
<b>Relative Humidity</b>	< 95 % (non condensing). Drive must be Frost and moisture free at all times.	

Branch circuit protection must be installed according to the relevant national codes. Fuse ratings and types are shown on Seite 9.

Suitable Power and motor cables should be selected according to the data. Power cable connections and tightening torques are shown on Seite 9. Only a single conductor type is allowed in each field wiring terminal when connected in group installation arrangement.

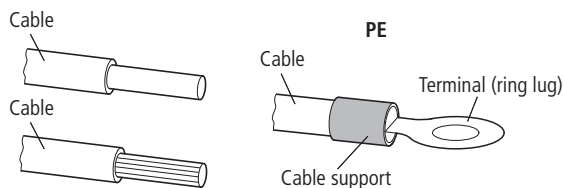

## Motor Overload Protection

DC1 provides motor overload protection in accordance with the National Electrical Code (US).

- Where a motor thermistor is not fitted, or not utilised, Thermal Overload Memory Retention must be enabled by setting P-51 = 0. Set the parameters P1-08 „Current Limit“ on motor current.
- Where a motor thermistor is fitted and connected to the drive, connection must be carried out according to the information, refer to Manual.

- 
- Ratings shown above apply to 50 °C (122 °F) Ambient temperature. For derating information, refer to Manual.
  - The maximum motor cable length stated applies to using a shielded motor cable. When using an unshielded cable, the maximum cable length limit may be increased by 50 %. When using the Eaton Drives recommended output choke, the maximum cable length may be increased by 100 %
  - The PWM output switching from any inverter when used with a long motor cable length can cause an increase in the voltage at the motor terminals, depending on the motor cable length and inductance. The rise time and peak voltage can affect the service life of the motor. Eaton Drives recommend using an output choke for motor cable lengths of 50 m or more to ensure good motor service life
  - For UL compliant installation, use Copper wire with a minimum insulation temperature rating of 75 °C (167 °F), UL Class CC or Class J fuses.

04/21 IL04020009Z

