



**Variable frequency drive, 500 V AC, 3-phase, 10 A, 5.5 kW, IP54/NEMA12,  
Brake chopper, DC link choke**



**Part no. DG1-35010FB-C54C**  
**Catalog No. 9703-2102-00P**  
**Alternate Catalog No. DG1-35010FB-C54C**

**Delivery program**

Product range			Variable frequency drives
Part group reference (e.g. DIL)			DG1
Rated operational voltage	$U_e$		600 V AC, 3-phase
Output voltage with $V_e$	$U_2$		600 V AC, 3-phase
Mains voltage (50/60Hz)	$U_{LN}$	V	500 (-10%) - 600 (+10%)
<b>Rated operational current</b>			
At 150% overload	$I_e$	A	10
At 110% overload	$I_e$	A	13.5
Note			Rated operational current for a switching frequency of 1 - 6 kHz and an ambient temperature of +50 °C for a 150% overload and +40 °C for a 110% overload
<b>Assigned motor rating</b>			
Note			for normal internally and externally ventilated 4 pole, three-phase asynchronous motors with 1500 rpm <sup>-1</sup> at 50 Hz or 1800 min <sup>-1</sup> at 60 Hz
Note			Overload cycle for 60 s every 600 s
Note			at 525 V, 50 Hz
150 % Overload	P	kW	5.5
110 % Overload	P	kW	7.5
150 % Overload	$I_M$	A	9
110 % Overload	$I_M$	A	12.1
Note			at 600 V, 50 Hz
150 % Overload	P	kW	5.5
110 % Overload	P	kW	7.5
150 % Overload	$I_M$	A	8
110 % Overload	$I_M$	A	10.6
Note			at 600 V, 60 Hz
150 % Overload	P	HP	7.5
110 % Overload	P	HP	10
150 % Overload	$I_M$	A	9
110 % Overload	$I_M$	A	11
Degree of Protection			IP54/NEMA12
Interface/field bus (built-in)			Modbus RTU Modbus TCP BACnet MS/TP Ethernet IP
Fieldbus connection (optional)			PROFIBUS CANopen® DeviceNet SmartWire-DT
Fitted with			Radio interference suppression filter Additional PCB protection Multi-line graphic display Brake chopper DC link choke
Parameterization			Keypad Fieldbus Power Xpert inControl
Frame size			FS2
Connection to SmartWire-DT			yes in conjunction with DXG-NET-SWD SmartWire DT module

## Technical data

### General

Standards			Specification for general requirements: IEC/EN 61800-2 EMC requirements: IEC/EN 61800-3 Safety requirements: IEC/EN 61800-5
Certifications			UL, cUL, c-Tick, UkrSEPRO, EAC
Production quality			RoHS, ISO 9001
Climatic proofing	$\rho_w$	%	< 95%, average relative humidity (RH), non-condensing, non-corrosive
Air quality			3C2, 3S2
Ambient temperature			
Operating ambient temperature min.		°C	-10
Operating ambient temperature max.		°C	+50
operation (110 % overload)	$\theta$	°C	-10 - +40
			Operation with 110 % overload (1 min./10 min.): -10 to +40 (max. +55 with 1% derating per Kelvin above limit) Operation with 150% overload (1 min./10 min.): -10 to +50 (max. +60 with 1% derating per Kelvin above limit) -20 with cold-weather mode
Storage	$\theta$	°C	-40 - +70
Overvoltage category			III
Pollution degree			2
Radio interference level			
Radio interference class (EMC)			C1 (with external filter, for conducted emissions only), C2, C3, depending on the motor cable length, the connected load, and ambient conditions. External radio interference suppression filters (optional) may be necessary.
Environment (EMC)			1st and 2nd environments as per EN 61800-3
maximum motor cable length	l	m	C3 ≤ 10 m
Mechanical shock resistance		g	EN 61800-5-1, EN 60068-2-27 UPS drop test (for weights inside the UPS frame) Storage and transportation: maximum 15 g, 11 ms (inside the packaging)
Vibration			EN 61800-5-1, EN 60068-2-6: 5 - 150 Hz Amplitude: 1 mm (peak) at 5 - 15.8 Hz Maximum acceleration amplitude: 1 g at 15.8 – 150 Hz
Mounting position			Vertical
Altitude		m	0 - 1000 m above sea level Above 1000 m: 1% derating for every 100 m max. 2000 m
Degree of Protection			IP54/NEMA12
Protection against direct contact			BGV A3 (VBG4, finger- and back-of-hand proof)

### Main circuit

Supply			
Rated operational voltage	$U_e$		600 V AC, 3-phase
Mains voltage (50/60Hz)	$U_{LN}$	V	500 (-10%) - 600 (+10%)
Input current (150% overload)	$I_{LN}$	A	9.3
Input current (110% overload)	$I_{LN}$	T	12.5
System configuration			TN-S, TN-C, TN-C-S, TT, IT
Supply frequency	$f_{LN}$	Hz	50/60
Frequency range	$f_{LN}$	Hz	45–66 (± 0%)
Mains switch-on frequency			Maximum of one time every 60 seconds
Mains current distortion	THD	%	36.7
Rated conditional short-circuit current	$I_q$	kA	< 100
Power section			
Function			Variable frequency drive with internal DC link, DC link choke and IGBT inverter
Overload current (150% overload)	$I_L$	A	15
Overload current (110% overload)	$I_L$	A	14.85
max. starting current (High Overload)	$I_H$	%	200
Note about max. starting current			for 2 seconds every 20 seconds
Output voltage with $V_e$	$U_2$		600 V AC, 3-phase
Output Frequency	$f_2$	Hz	0 - 50/60 (max. 400)
Switching frequency	$f_{PWM}$	kHz	1.5 adjustable 1 - 6

Operation Mode			U/f control Speed control with slip compensation sensorless vector control (SLV) Torque regulation
Frequency resolution (setpoint value)	$\Delta f$	Hz	0.01
Rated operational current			
At 150% overload	$I_e$	A	10
At 110% overload	$I_e$	A	13.5
Note			Rated operational current for a switching frequency of 1 - 6 kHz and an ambient temperature of +50 °C for a 150% overload and +40 °C for a 110% overload
Motor current limit	$I$	A	0.1 - 2 x $I_H$ (CT)
Power loss			
Heat dissipation at rated operational current $I_e = 150\%$	$P_V$	W	153
Heat dissipation at rated operational current $I_e = 110\%$	$P_V$	W	221
Efficiency	$\eta$	%	98.2
Maximum leakage current to ground (PE) without motor	$I_{PE}$	mA	9.8
Fan			temperature controlled Tool-less swapping
Internal fan delivery rate		$m^3/h$	94
Fitted with			Radio interference suppression filter Additional PCB protection Multi-line graphic display Brake chopper DC link choke
Safety function			STO (Safe Torque Off, SIL1, PLc Cat 1)
Frame size			FS2
Motor feeder			
Note			for normal internally and externally ventilated 4 pole, three-phase asynchronous motors with 1500 rpm <sup>-1</sup> at 50 Hz or 1800 min <sup>-1</sup> at 60 Hz
Note			Overload cycle for 60 s every 600 s
Note			at 525 V, 50 Hz
150 % Overload	P	kW	5.5
110 % Overload	P	kW	7.5
Note			at 600 V, 50 Hz
150 % Overload	P	kW	5.5
110 % Overload	P	kW	7.5
Note			at 600 V, 60 Hz
150 % Overload	P	HP	7.5
110 % Overload	P	HP	10
maximum permissible cable length	$l$	m	screened: 150
Apparent power			
Apparent power at rated operation 600 V	S	kVA	14
Braking function			
Standard braking torque			max. 30 % $M_N$
DC braking torque			adjustable to 150 %
Braking torque with external braking resistance			Max. 100% of rated operational current $I_e$ with external braking resistor
minimum external braking resistance	$R_{min}$	$\Omega$	30
Switch-on threshold for the braking transistor	$U_{DC}$	V	Supply voltage UAUX 1050 V DC
DC braking	%	$I/I_e$	$\leq 150$ , adjustable
<b>Control section</b>			
External control voltage	$U_c$	V	24 V DC (max. 250 mA options incl.)
Reference voltage	$U_s$	V	10 V DC (max. 10 mA)
Analog inputs			2, parameterizable, 0 - 10 V DC, 2 - 10 V DC, -10 - +10 V DC, 0/4 - 20 mA
Analog outputs			2, parameterizable, 0 - 10 V, 0/4 - 20 mA
Digital inputs			8, parameterizable, max. 30 V DC
Digital outputs			1, parameterizable, 24 V DC
Relay outputs			3, parameterizable, 2 changeover contacts and 1 N/O, 6 A (240 VAC) / 6 A (24 VDC)
Interface/field bus (built-in)			Modbus RTU Modbus TCP

			BACnet MS/TP Ethernet IP
Expansion slots			2
<b>Assigned switching and protective elements</b>			
<b>Power Wiring</b>			
Safety device (fuse or miniature circuit-breaker)			
IEC (Type B, gG), 150 %			PKZM0-10
IEC (Type B, gG), 110 %			PKZM0-16
UL (Class CC or J)		A	20
Mains contactor			
150 % overload (CT/I <sub>H</sub> , at 50 °C)			DILM7
110 % overload (VT/I <sub>L</sub> , at 40 °C)			DILM7
Main choke			
150 % overload (CT/I <sub>H</sub> , at 50 °C)			Integrated DC link choke, uk = 5%
110 % overload (VT/I <sub>L</sub> , at 40 °C)			Integrated DC link choke, uk = 5%
Note regarding radio interference suppression filter			Optional external radio interference suppression filter for longer motor cable lengths and for use in different EMC environments
<b>DC link connection</b>			
Braking resistance			
10 % duty factor (DF)			DX-BR040-3K1
20 % duty factor (DF)			DX-BR040-5K1
40 % duty factor (DF)			DX-BR047-9K2
Notes concerning braking resistances:			PnRm: = Connect every "n" resistors in parallel, then connect the resulting combinations "m" times in series. A total of "n" x "m" resistors will be needed.
<b>Motor feeder</b>			
motor choke			
150 % overload (CT/I <sub>H</sub> , at 50 °C)			DX-LM3-011
110 % overload (VT/I <sub>L</sub> , at 40 °C)			DX-LM3-016
Sine filter			
150 % overload (CT/I <sub>H</sub> , at 50 °C)			DX-SIN3-010
110 % overload (VT/I <sub>L</sub> , at 40 °C)			DX-SIN3-016
All-pole sine filter			
150 % overload (CT/I <sub>H</sub> , at 50 °C)			DX-SIN3-013-A
110 % overload (VT/I <sub>L</sub> , at 40 °C)			DX-SIN3-024-A

## Design verification as per IEC/EN 61439

<b>Technical data for design verification</b>			
Rated operational current for specified heat dissipation	I <sub>n</sub>	A	10
Heat dissipation per pole, current-dependent	P <sub>vid</sub>	W	0
Equipment heat dissipation, current-dependent	P <sub>vid</sub>	W	221
Static heat dissipation, non-current-dependent	P <sub>vs</sub>	W	23.19
Heat dissipation capacity	P <sub>diss</sub>	W	0
Operating ambient temperature min.		°C	-10
Operating ambient temperature max.		°C	50
			Operation (with 150 % overload), allow for derating
<b>IEC/EN 61439 design verification</b>			
10.2 Strength of materials and parts			
10.2.2 Corrosion resistance			
Meets the product standard's requirements.			
10.2.3.1 Verification of thermal stability of enclosures			
Meets the product standard's requirements.			
10.2.3.2 Verification of resistance of insulating materials to normal heat			
Meets the product standard's requirements.			
10.2.3.3 Verification of resistance of insulating materials to abnormal heat and fire due to internal electric effects			
Meets the product standard's requirements.			
10.2.4 Resistance to ultra-violet (UV) radiation			
Meets the product standard's requirements.			
10.2.5 Lifting			
Does not apply, since the entire switchgear needs to be evaluated.			
10.2.6 Mechanical impact			
Does not apply, since the entire switchgear needs to be evaluated.			
10.2.7 Inscriptions			
Meets the product standard's requirements.			

10.3 Degree of protection of ASSEMBLIES		Does not apply, since the entire switchgear needs to be evaluated.
10.4 Clearances and creepage distances		Meets the product standard's requirements.
10.5 Protection against electric shock		Does not apply, since the entire switchgear needs to be evaluated.
10.6 Incorporation of switching devices and components		Does not apply, since the entire switchgear needs to be evaluated.
10.7 Internal electrical circuits and connections		Is the panel builder's responsibility.
10.8 Connections for external conductors		Is the panel builder's responsibility.
10.9 Insulation properties		
10.9.2 Power-frequency electric strength		Is the panel builder's responsibility.
10.9.3 Impulse withstand voltage		Is the panel builder's responsibility.
10.9.4 Testing of enclosures made of insulating material		Is the panel builder's responsibility.
10.10 Temperature rise		The panel builder is responsible for the temperature rise calculation. Eaton will provide heat dissipation data for the devices.
10.11 Short-circuit rating		Is the panel builder's responsibility. The specifications for the switchgear must be observed.
10.12 Electromagnetic compatibility		Is the panel builder's responsibility. The specifications for the switchgear must be observed.
10.13 Mechanical function		The device meets the requirements, provided the information in the instruction leaflet (IL) is observed.

## Technical data ETIM 6.0

Low-voltage industrial components (EG000017) / Frequency converter =< 1 kV (EC001857)			
Electric engineering, automation, process control engineering / Electrical drive / Static frequency converter / Static frequency converter = < 1 kv (ec@ss8.1-27-02-31-01 [AKE177011])			
Mains voltage	V		525 - 600
Mains frequency			50/60 Hz
Number of phases input			3
Number of phases output			3
Max. output frequency	Hz		400
Max. output voltage	V		575
Rated output current I2N	A		10
Max. output at quadratic load at rated output voltage	kW		7.5
Max. output at linear load at rated output voltage	kW		11
With control unit			Yes
Application in industrial area permitted			Yes
Application in domestic- and commercial area permitted			Yes
Supporting protocol for TCP/IP			Yes
Supporting protocol for PROFIBUS			Yes
Supporting protocol for CAN			Yes
Supporting protocol for INTERBUS			No
Supporting protocol for ASI			No
Supporting protocol for KNX			No
Supporting protocol for MODBUS			Yes
Supporting protocol for Data-Highway			No
Supporting protocol for DeviceNet			Yes
Supporting protocol for SUCONET			No
Supporting protocol for LON			No
Supporting protocol for PROFINET IO			Yes
Supporting protocol for PROFINET CBA			No
Supporting protocol for SERCOS			No
Supporting protocol for Foundation Fieldbus			No
Supporting protocol for EtherNet/IP			No
Supporting protocol for AS-Interface Safety at Work			No
Supporting protocol for DeviceNet Safety			No
Supporting protocol for INTERBUS-Safety			No
Supporting protocol for PROFIsafe			No
Supporting protocol for SafetyBUS p			No
Supporting protocol for other bus systems			Yes
Number of HW-interfaces industrial Ethernet			1

Number of HW-interfaces PROFINET			1
Number of HW-interfaces RS-232			0
Number of HW-interfaces RS-422			0
Number of HW-interfaces RS-485			1
Number of HW-interfaces serial TTY			0
Number of HW-interfaces USB			0
Number of HW-interfaces parallel			0
Number of HW-interfaces other			1
With optical interface			No
With PC connection			Yes
Integrated breaking resistance			Yes
4-quadrant operation possible			Yes
Type of converter			U converter
Degree of protection (IP)			IP54
Height		mm	419
Width		mm	169
Depth		mm	244
Relative symmetric net frequency tolerance		%	10
Relative symmetric net current tolerance		%	10

## Approvals

Product Standards			UL508C, CSA-C22.2 No. 274-13; IEC/EN61800-3; IEC/EN61800-5; CE marking
UL File No.			E134360
UL Category Control No.			NMMS, NMMS7
CSA File No.			UL report applies to both US and Canada
North America Certification			UL listed, certified by UL for use in Canada
Suitable for			Branch circuits
Max. Voltage Rating			3-600 V AC IEC: TN-S UL/CSA: 'Y' (Solidly Grounded Wey)
Degree of Protection			IP54/NEMA12

## Dimensions

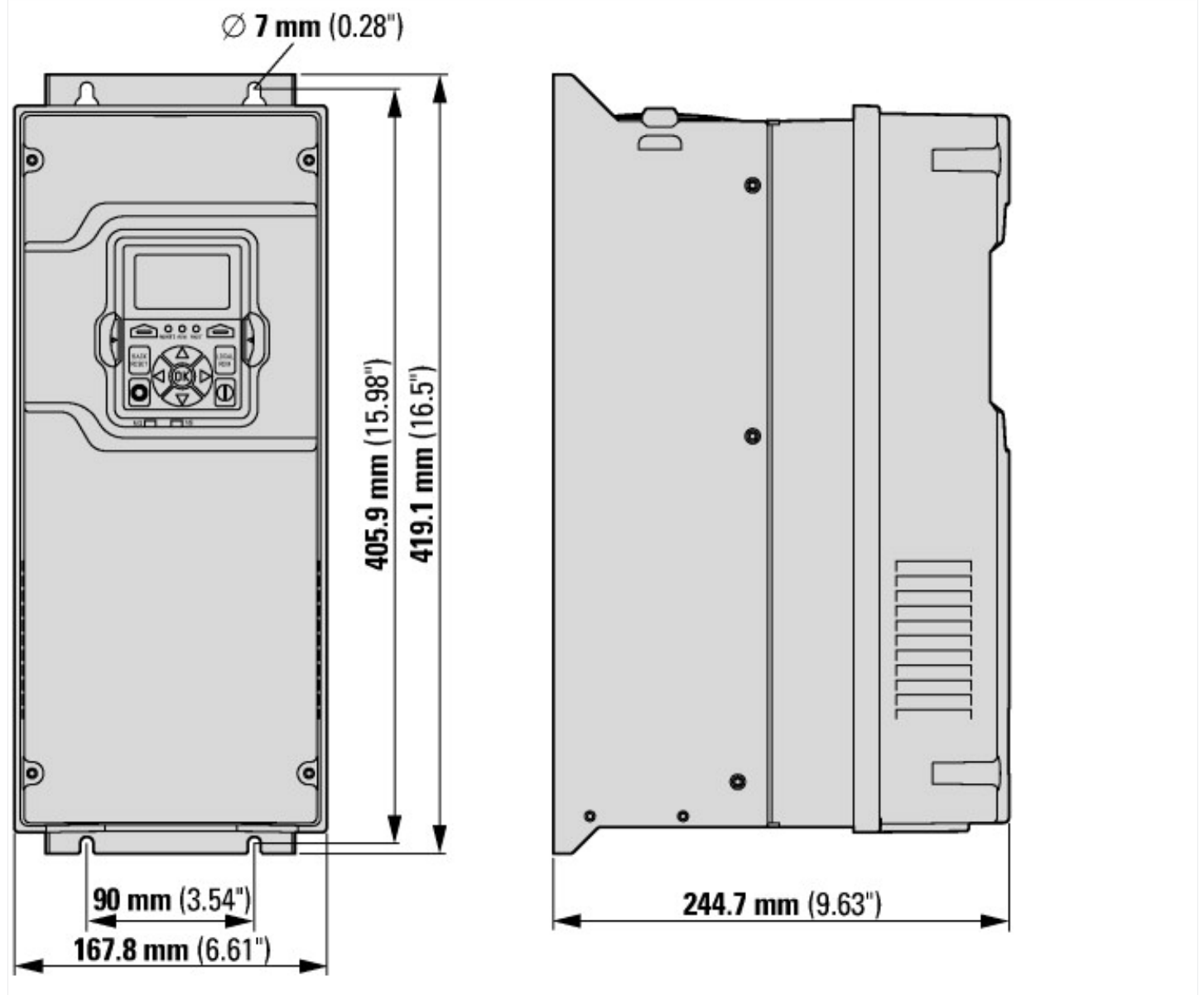

## Additional product information (links)

Documentation	<a href="http://www.eaton.eu/Europe/Electrical/ProductsServices/AutomationControl/SwitchingProtectingDrivingMotors/PowerXLfrequencydrives/DG1GeneralPurposeDrives/index.htm?wtredirect=www.eaton.eu/dg1#tabs-7">http://www.eaton.eu/Europe/Electrical/ProductsServices/AutomationControl/SwitchingProtectingDrivingMotors/PowerXLfrequencydrives/DG1GeneralPurposeDrives/index.htm?wtredirect=www.eaton.eu/dg1#tabs-7</a>
Manuals	<a href="http://www.eaton.eu/Europe/Electrical/ProductsServices/AutomationControl/SwitchingProtectingDrivingMotors/PowerXLfrequencydrives/DG1GeneralPurposeDrives/index.htm?wtredirect=www.eaton.eu/dg1#tabs-8">http://www.eaton.eu/Europe/Electrical/ProductsServices/AutomationControl/SwitchingProtectingDrivingMotors/PowerXLfrequencydrives/DG1GeneralPurposeDrives/index.htm?wtredirect=www.eaton.eu/dg1#tabs-8</a>