



Speed controllers, 8.5 A, 4 kW, Sensor input 4, 400/480 V AC, AS-Interface®, S-7.4 for 31 modules, HAN Q4/2, with braking resistance, STO (Safe Torque Off), with fan



Part no. RASP5-8404A31-4120111S1  
 Catalog No. 198851

## Delivery program

Product range			Speed controller
Rated operational voltage	$U_e$		400 V AC, 3-phase 480 V AC, 3-phase
Output voltage with $V_e$	$U_2$		0 - $U_{LN}$
Mains voltage (50/60Hz)	$U_{LN}$	V	380 (-15%) - 480 (+10%)
At 150% overload	$I_e$	A	8.5
<b>assigned motor rating P</b>			
Note			at 400 V, 50 Hz
150 % Overload	P	kW	4
Note			at 480 V, 60 Hz
150 % Overload	P	HP	5
Note			for normal internally and externally ventilated 4 pole, three-phase asynchronous motors with $1500 \text{ rpm}^{-1}$ at 50 Hz or $1800 \text{ min}^{-1}$ at 60 Hz
Description			integrated PTC thermistor monitoring and Thermoclick with safe isolation Two sensor inputs through M12 sockets (max. 150 mA) for quick stop and interlocked manual operation optional: 4 sensor inputs with M12-Y adapter for switchover to creep speed Connection of supply voltage via adapter cable on round or flexible busbar junction Diagnostics and reset on device and via AS-Interface with AUTO - OFF/RESET - HAND key switches 3 fixed speeds and 1 potentiometer speed can be switched over from U/f to (vector) speed control with selector switch REV - OFF - FWD optional: Faster stop if external 24 V fails
Sensor input		Number	4
Control voltage external brake (50/60 Hz)		V	400/480 V AC
Interface/field bus (built-in)			AS-Interface®
AS-Interface profile cable			S-7.4 for 31 modules
Plug arrangement			HAN Q4/2
Braking resistance			with braking resistance
Safety function			STO (Safe Torque Off)
Fan			with fan
Parameterization			Keypad Fieldbus drivesConnect drivesConnect mobile (App)
<b>Instructions</b> for actuation of motors with mechanical brake integrated brake chopper with braking resistance for dynamic braking			

## Technical data

<b>General</b>			
Standards			IEC/EN 61800-5-1 UL 61800-5-1 Guideline 2011/65/EU (RoHS) CE approval UL approval
Climatic proofing	$\rho_w$	%	< 95%, non-condensing IEC/EN 50178
<b>Ambient temperature</b>			
Operating ambient temperature min.		°C	-10
Operating ambient temperature max.		°C	+40
			-10 – +50 with derating (see manual)
Storage	$\theta$	°C	-40 - +70

Overvoltage category			III
Rated impulse withstand voltage	$U_{imp}$	kV	2
Radio interference level			
Radio interference class (EMC)			C1 (for conducted emissions only), C2, C3, depending on the motor cable length, the connected load, and ambient conditions.
Environment (EMC)			1st and 2nd environments as per EN 61800-3
maximum motor cable length	l	m	C1 ≤ 1 m C2 ≤ 5 m C3 ≤ 25 m
Mechanical shock resistance		g	1000 shocks per shaft, semi-sinusoidal 15 g/11 ms IEC/EN 60068-2-27
Vibration			Oscillation frequency: 10 - 150 Hz Amplitude 0.15 mm: 6 Hz Amplitude transition frequency on acceleration: 57 Hz IEC/EN 60068-2-6
Mounting position			Vertical
Altitude		m	0 - 1000 m above sea level above 1000 m with 1 % performance reduction per 100 m max. 2000 m
Degree of Protection			IP65 NEMA12

### Main circuit

Supply			
Rated operational voltage	$U_e$		400 V AC, 3-phase 480 V AC, 3-phase
Mains voltage (50/60Hz)	$U_{LN}$	V	380 (-15%) - 480 (+10%)
Input current (150% overload)	$I_{LN}$	A	7.8
System configuration			AC voltage Center-point earthed star network (TN-S network) Phase-earthed AC supply systems are not permitted.
Supply frequency	$f_{LN}$	Hz	50/60
Frequency range	$f_{LN}$	Hz	45–66 (± 0%)
Mains switch-on frequency			Maximum of one time every 60 seconds
Mains current distortion	THD	%	< 120
Rated conditional short-circuit current	$I_q$	kA	< 10
Short-circuit protection for output circuits, external			Type 1 coordination via the power bus' feeder unit
Power section			
Function			Variable frequency drive with internal DC link and IGBT inverter
On-delay	$t_{0N}$	ms	< 10
Off-delay	$t_{0FF}$	ms	< 10
Overload current (150% overload)	$I_L$	A	12.7
Note regarding overload current			For 60 s every 600 s at 40 °C
max. starting current (High Overload)	$I_H$	%	200
Note about max. starting current			at 40 °C
Output voltage with $V_e$	$U_2$		0 - $U_{LN}$
Output Frequency	$f_2$	Hz	0 - 50/60 (max. 500)
Switching frequency	$f_{PWM}$	kHz	8 adjustable 4 - 32
Operation Mode			U/f control sensorless vector control (SLV) PM and LSPM motors Synchronous reluctance motors BLDC motors
Frequency resolution (setpoint value)	$\Delta f$	Hz	0.1
Rated operational current			
At 150% overload	$I_e$	A	8.5
Note			Rated operational current at a switching frequency of 8 kHz and an ambient air temperature of +40 °C
Motor current limit	l	A	0,8 - 8,5 adjustable
Power loss			
Heat dissipation at rated operational current $I_e = 150\%$	$P_V$	W	95

Efficiency	$\eta$	%	98
Maximum leakage current to ground (PE) without motor	$I_{PE}$	mA	3.5
Fan			internal and on heat sink, temperature-controlled
Fitted with			without manual override switch with fan with braking resistance
Safety function			STO (Safe Torque Off)
Motor feeder			
Note			for normal internally and externally ventilated 4 pole, three-phase asynchronous motors with $1500 \text{ rpm}^{-1}$ at 50 Hz or $1800 \text{ min}^{-1}$ at 60 Hz
Note			at 400 V, 50 Hz
150 % Overload	P	kW	4
Note			at 480 V, 60 Hz
150 % Overload	P	HP	5
Actuator for external motor brake			
Braking voltage	U	V	400/480 V AC -15% / +10%
Braking current	I	A	$\leq 0.6 \text{ A}$ (max. 6 A for 120 ms)
Braking function			
Braking torque	%	$I/I_e$	$\leq 30$
Switch-on threshold for the braking transistor	$U_{DC}$	V	765 V DC
DC braking	%	$I/I_e$	$\leq 100$ , adjustable

### Control section

External control voltage	$U_c$	V	24 V DC - 15 % / + 20 % via AS-Interface <sup>®</sup> plug
Interface/field bus (built-in)			AS-Interface <sup>®</sup>
AS-Interface <sup>®</sup>			max. total power consumption from AS-Interface <sup>®</sup> power supply unit (30 V): 190 mA Specification: S-7.4 Number of slave addresses: 31

### Design verification as per IEC/EN 61439

Technical data for design verification			
Operating ambient temperature min.		°C	-10
Operating ambient temperature max.		°C	40

## Dimensions

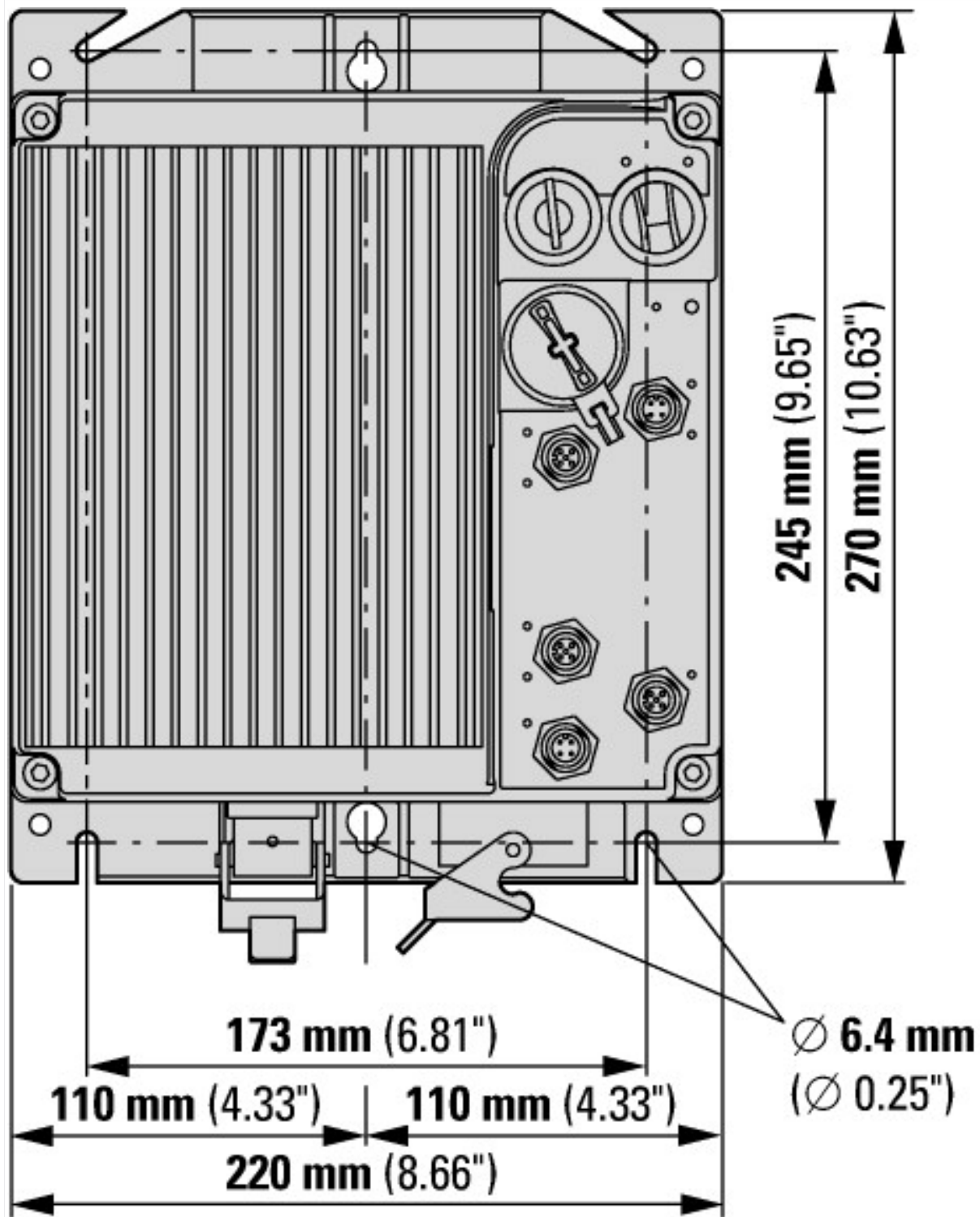

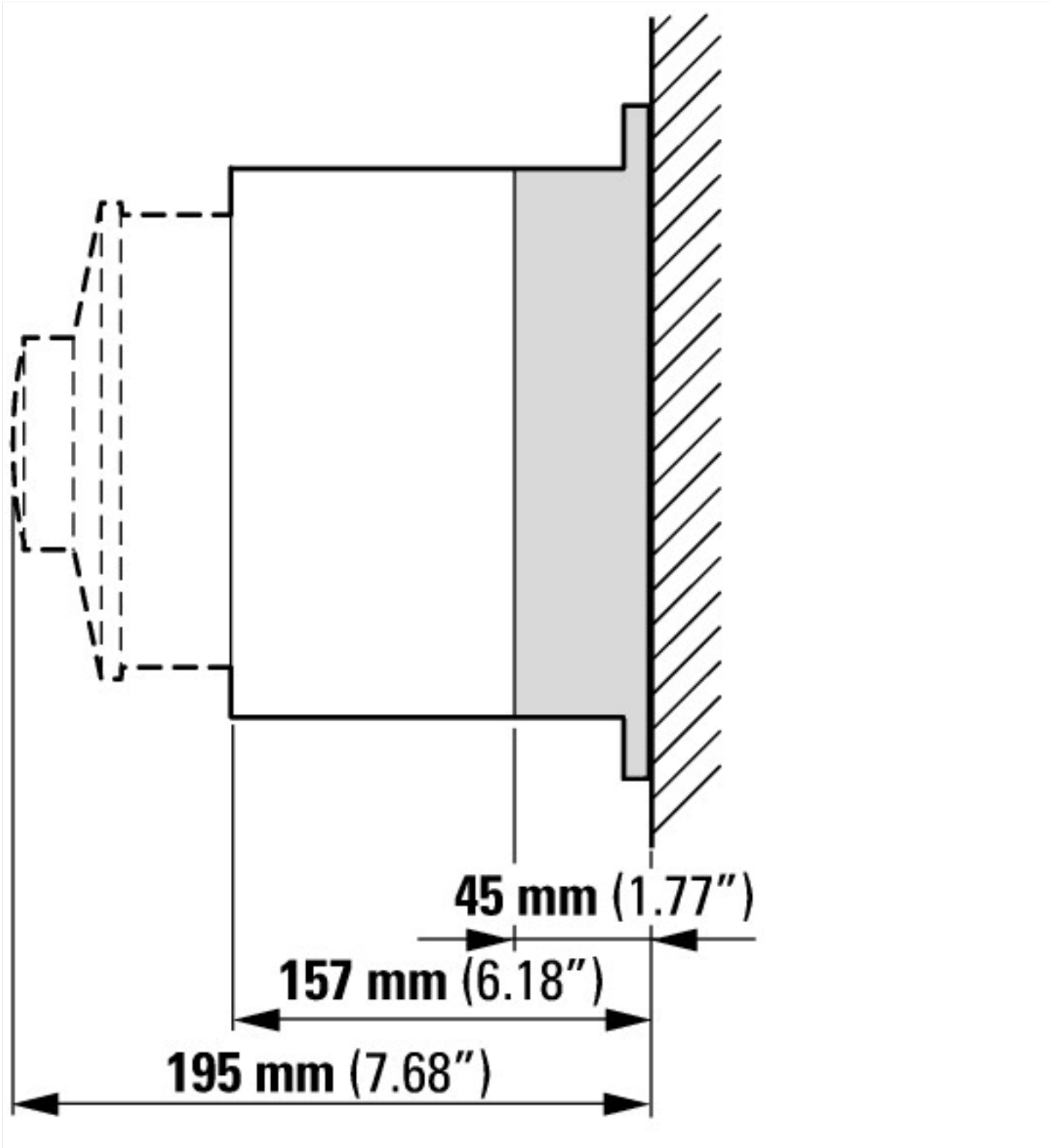

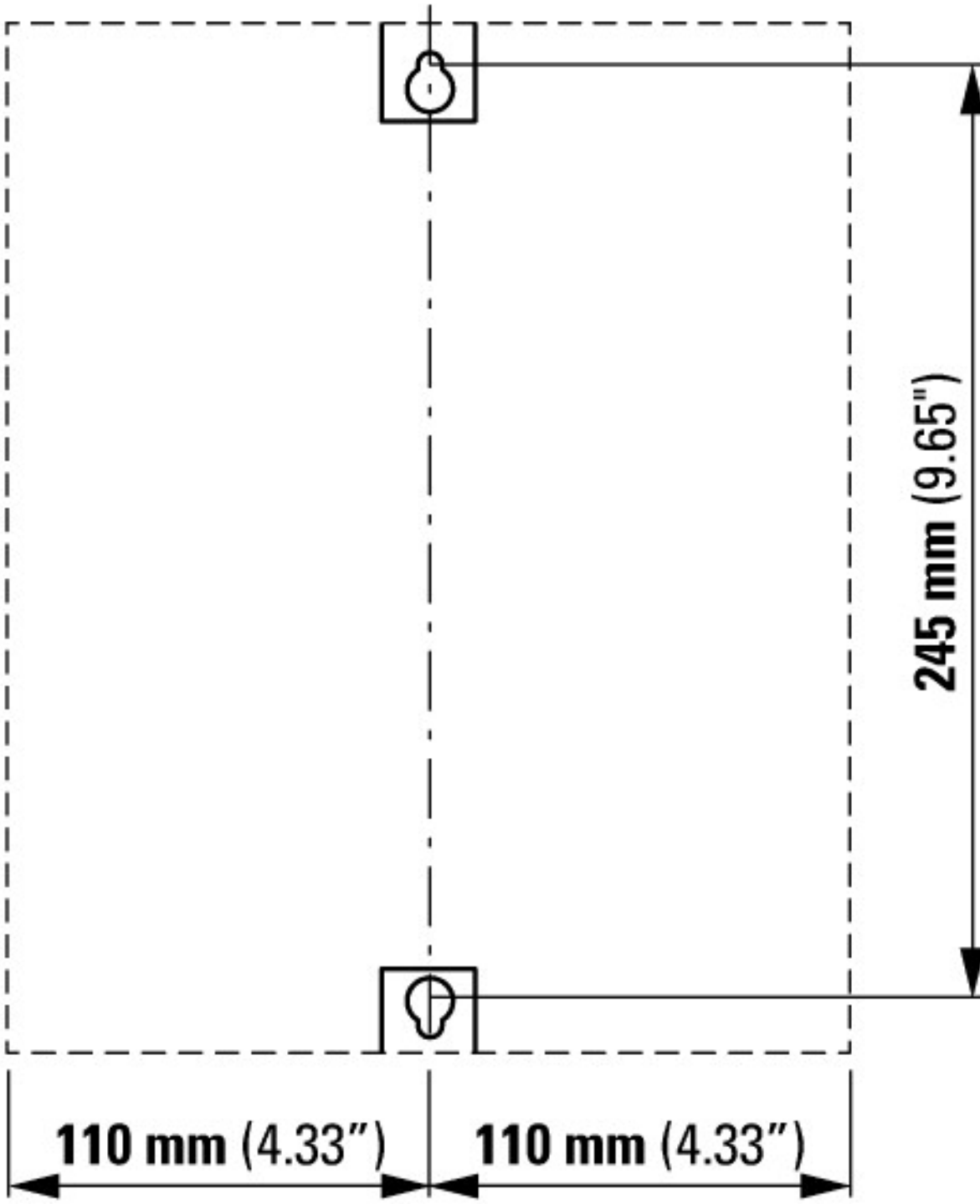

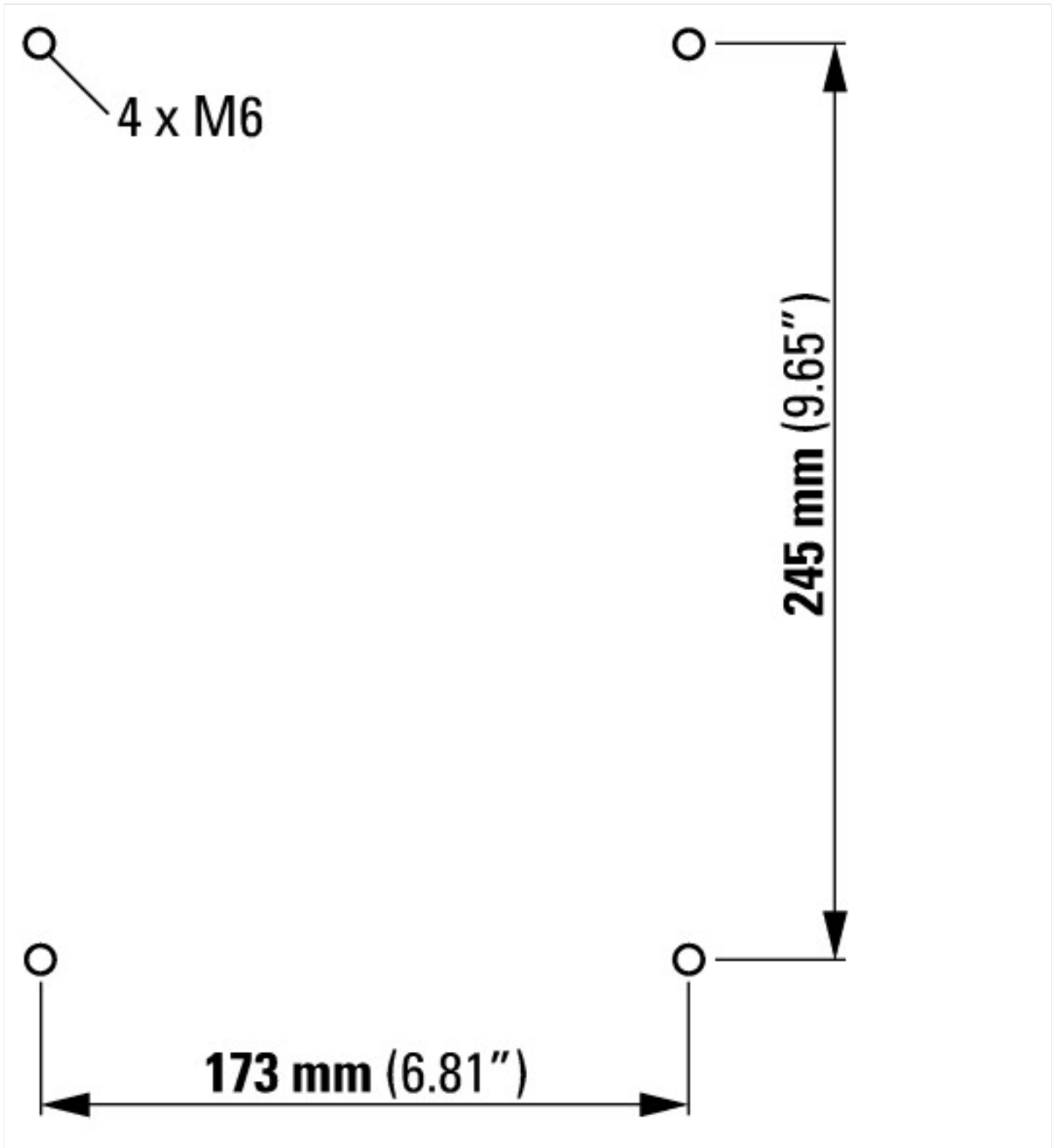

### Additional product information (links)

#### IL034085ZU Rapid Link 5 Speed Control Unit

IL034085ZU Rapid Link 5 Speed Control Unit [https://es-assets.eaton.com/DOCUMENTATION/AWA\\_INSTRUCTIONS/IL034085ZU2020\\_06.pdf](https://es-assets.eaton.com/DOCUMENTATION/AWA_INSTRUCTIONS/IL034085ZU2020_06.pdf)

#### MN034004 Rapid Link 5.0 RAMO RASP

MN034004 Schnellverbindung 5.0 RAMO RASP [https://es-assets.eaton.com/DOCUMENTATION/AWB\\_MANUALS/MN034004\\_DE.pdf](https://es-assets.eaton.com/DOCUMENTATION/AWB_MANUALS/MN034004_DE.pdf)  
- Deutsch

MN034004 Rapid Link 5.0 RAMO RASP - English [https://es-assets.eaton.com/DOCUMENTATION/AWB\\_MANUALS/MN034004EN.pdf](https://es-assets.eaton.com/DOCUMENTATION/AWB_MANUALS/MN034004EN.pdf)