

DC switch disconnecter, 1250 A, 2 pole, 1 N/O, 1 N/C, with grey knob, service distribution board mounting

Part no. DDC-1250/2
Catalog No. 6098956

Delivery program

Product range			DC switch-disconnector Main switch maintenance switch
Part group reference			DDC with grey knob
Information about equipment supplied			auxiliary contact fitted by user.
Number of poles			2 pole
Auxiliary contacts			
		N/O	1
		N/C	1
Degree of Protection			IP20
Design			service distribution board mounting
Rated uninterrupted current	I_u	A	1250
Note on rated uninterrupted current I_u			Rated uninterrupted current I_u is specified for max. cross-section.

Technical data

General

Standards			IEC/EN 60947, VDE 0660, IEC/EN 60204 Switch-disconnector according to IEC/EN 60947-3
Certifications			CE, RoHs
Ambient temperature			
Operation	θ	°C	-25 - +55
Storage	θ	°C	-30 - +80
Overvoltage category/pollution degree			III/3
Rated impulse withstand voltage	U_{imp}	kV	12
Rated insulation voltage	U_i	V	1200
Mounting position			As required

Contacts

Mechanical variables			
Number of poles			2 pole
Auxiliary contacts			
		N/O	1
		N/C	1
Electrical characteristics			
Rated uninterrupted current	I_u	A	1250
Note on rated uninterrupted current I_u			Rated uninterrupted current I_u is specified for max. cross-section.
Rated short-time withstand current (1 s current)	I_{cw}	A_{rms}	25000
Note on rated short-time withstand current I_{cw}			Current for a time of 1 second
Rated short-circuit making capacity	I_{cm}	kA_{eff}	54.5

Heat dissipation per pole, current-dependent	P _{vid}	W	83
Switching capacity			
Lifespan, mechanical	Operations		5000
DC			
Utilization category DC21B			
Rated operational current switch			
480 V	I _e	A	1250
600 V	I _e	A	1250
1000 V	I _e	A	1250

Terminal capacities

Flat conductor connection with busbars		mm ²	2 x (80 x 5)
Terminal screw			M12 (2 x)
Tightening torque for terminal screw		Nm	28

Design verification as per IEC/EN 61439

Technical data for design verification			
Rated operational current for specified heat dissipation	I _n	A	1250
Heat dissipation per pole, current-dependent	P _{vid}	W	83
Equipment heat dissipation, current-dependent	P _{vid}	W	0
Static heat dissipation, non-current-dependent	P _{vs}	W	0
Heat dissipation capacity	P _{diss}	W	0
Operating ambient temperature min.		°C	-25
Operating ambient temperature max.		°C	55
IEC/EN 61439 design verification			
10.2 Strength of materials and parts			
10.2.2 Corrosion resistance			Meets the product standard's requirements.
10.2.3.1 Verification of thermal stability of enclosures			Meets the product standard's requirements.
10.2.3.2 Verification of resistance of insulating materials to normal heat			Meets the product standard's requirements.
10.2.3.3 Verification of resistance of insulating materials to abnormal heat and fire due to internal electric effects			Meets the product standard's requirements.
10.2.4 Resistance to ultra-violet (UV) radiation			Meets the product standard's requirements.
10.2.5 Lifting			Does not apply, since the entire switchgear needs to be evaluated.
10.2.6 Mechanical impact			Does not apply, since the entire switchgear needs to be evaluated.
10.2.7 Inscriptions			Meets the product standard's requirements.
10.3 Degree of protection of ASSEMBLIES			Does not apply, since the entire switchgear needs to be evaluated.
10.4 Clearances and creepage distances			Meets the product standard's requirements.
10.5 Protection against electric shock			Does not apply, since the entire switchgear needs to be evaluated.
10.6 Incorporation of switching devices and components			Does not apply, since the entire switchgear needs to be evaluated.
10.7 Internal electrical circuits and connections			Is the panel builder's responsibility.
10.8 Connections for external conductors			Is the panel builder's responsibility.
10.9 Insulation properties			
10.9.2 Power-frequency electric strength			Is the panel builder's responsibility.
10.9.3 Impulse withstand voltage			Is the panel builder's responsibility.
10.9.4 Testing of enclosures made of insulating material			Is the panel builder's responsibility.
10.10 Temperature rise			The panel builder is responsible for the temperature rise calculation. Eaton will provide heat dissipation data for the devices.
10.11 Short-circuit rating			Is the panel builder's responsibility. The specifications for the switchgear must be observed.
10.12 Electromagnetic compatibility			Is the panel builder's responsibility. The specifications for the switchgear must be observed.
10.13 Mechanical function			The device meets the requirements, provided the information in the instruction leaflet (IL) is observed.

Technical data ETIM 7.0

Low-voltage industrial components (EG000017) / Switch disconnecter (EC000216)

Electric engineering, automation, process control engineering / Low-voltage switch technology / Off-load switch, circuit breaker, control switch / Switch disconnecter (ecl@ss10.0.1-27-37-14-03 [AKF060013])

Version as main switch		Yes
Version as maintenance-/service switch		Yes
Version as safety switch		No
Version as emergency stop installation		No
Version as reversing switch		No
Number of switches		1
Max. rated operation voltage Ue AC	V	0
Rated operating voltage	V	1000 - 1000
Rated permanent current Iu	A	1250
Rated permanent current at AC-23, 400 V	A	0
Rated permanent current at AC-21, 400 V	A	0
Rated operation power at AC-3, 400 V	kW	0
Rated short-time withstand current Icw	kA	25
Rated operation power at AC-23, 400 V	kW	0
Switching power at 400 V	kW	0
Conditioned rated short-circuit current Iq	kA	0
Number of poles		2
Number of auxiliary contacts as normally closed contact		0
Number of auxiliary contacts as normally open contact		0
Number of auxiliary contacts as change-over contact		0
Motor drive optional		No
Motor drive integrated		No
Voltage release optional		No
Device construction		Built-in device fixed built-in technique
Suitable for ground mounting		Yes
Suitable for front mounting 4-hole		No
Suitable for front mounting centre		No
Suitable for distribution board installation		No
Suitable for intermediate mounting		No
Colour control element		Grey
Type of control element		Long turning handle
Interlockable		Yes
Type of electrical connection of main circuit		Screw connection
Degree of protection (IP), front side		IP20
Degree of protection (NEMA)		Other

Dimensions

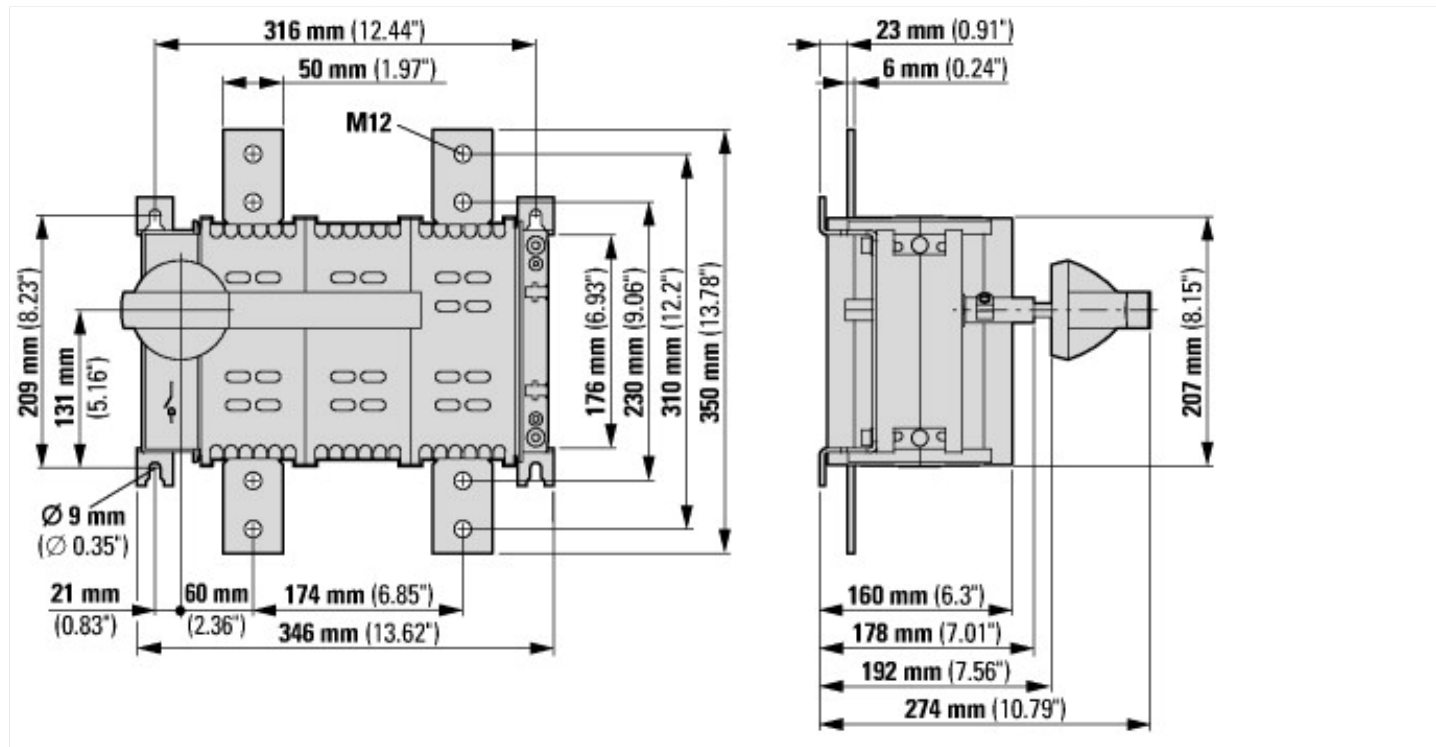

Assets (links)

Instruction Leaflets

IL008015ZU2018_05

Additional product information (links)

IL008015ZU Switch disconnecter DDC, DC-Switch (Box 3)

IL008015ZU Switch disconnecter DDC, DC-Switch (Box 3)	ftp://ftp.moeller.net/DOCUMENTATION/AWA_INSTRUCTIONS/IL008015ZU2018_05.pdf
Technical overview cam switch, switch-disconnector	http://de.ecat.moeller.net/flip-cat/?edition=HPLTEv1&startpage=4.2
System overview cam switch T	http://de.ecat.moeller.net/flip-cat/?edition=HPLTEv1&startpage=4.4
System overview switch-disconnector P	http://de.ecat.moeller.net/flip-cat/?edition=HPLTEv1&startpage=4.6
Key to part numbers Cam switch	http://de.ecat.moeller.net/flip-cat/?edition=HPLTEv1&startpage=4.8
Key to part numbers Switch-disconnector	http://de.ecat.moeller.net/flip-cat/?edition=HPLTEv1&startpage=4.8
Switches for ATEX	http://www.coopercrouse-hinds.eu/en/products/25-ex-safety-and-main-current-switches.html