



Variable frequency drive, 500 V AC, 3-phase, 9 A, 5.5 kW, IP20/NEMA 0, 7-digital display assembly



**Part no.** DA1-359D0NB-A20C  
**Catalog No.** 177038  
**Alternate Catalog No.** DA1-359D0NB-A20C  
**EL-Nummer (Norway)** 4110154

## Delivery program

Product range			Variable frequency drives
Part group reference (e.g. DIL)			DA1
Rated operational voltage	$U_e$		500 V AC, 3-phase 600 V AC, 3-phase
Output voltage with $V_e$	$U_2$		500 V AC, 3-phase 600 V AC, 3-phase
Mains voltage (50/60Hz)	$U_{LN}$	V	500 (-10%) - 600 (+10%)
<b>Rated operational current</b>			
At 150% overload	$I_e$	A	9
Note			Rated operational current at a switching frequency of 8 kHz and an ambient air temperature of +50 °C
<b>Assigned motor rating</b>			
Note			for normal internally and externally ventilated 4 pole, three-phase asynchronous motors with 1500 rpm <sup>-1</sup> at 50 Hz or 1800 min <sup>-1</sup> at 60 Hz
Note			Overload cycle for 60 s every 600 s
Note			at 500 V, 50 Hz
150 % Overload	P	kW	5.5
150 % Overload	$I_M$	A	9
Note			at 525 V, 50 Hz
150 % Overload	P	kW	5.5
150 % Overload	$I_M$	A	8.6
Note			at 550 - 600 V, 60 Hz
150 % Overload	P	HP	7.5
150 % Overload	$I_M$	A	9
Degree of Protection			IP20/NEMA 0
Interface/field bus (built-in)			OP-Bus (RS485)/Modbus RTU, CANopen®
Fieldbus connection (optional)			Ethernet IP DeviceNet PROFIBUS PROFINET Modbus-TCP EtherCAT SmartWire-DT
Fitted with			Brake chopper 7-digital display assembly Additional PCB protection
Frame size			FS2
Connection to SmartWire-DT			yes in conjunction with DX-NET-SWD1 SmartWire DT module

## Technical data

<b>General</b>			
Standards			Specification for general requirements: IEC/EN 61800-2 EMC requirements: IEC/EN 61800-3 Safety requirements: IEC/EN 61800-5-1
Certifications			CE, UL, cUL, RCM, UkrSEPRO, EAC
Production quality			RoHS, ISO 9001
Climatic proofing	$\rho_w$	%	< 95%, average relative humidity (RH), non-condensing, non-corrosive
Air quality			3C2, 3S2
Ambient temperature			

Operating ambient temperature min.		°C	-10
Operating ambient temperature max.		°C	+50
			operation (with 150 % overload)
Storage	θ	°C	-40 - +60
Mounting position			Vertical
Altitude		m	0 - 1000 m above sea level Above 1000 m: 1% derating for every 100 m max. 4000 m
Degree of Protection			IP20/NEMA 0
Protection against direct contact			BGV A3 (VBG4, finger- and back-of-hand proof)
<b>Main circuit</b>			
<b>Supply</b>			
Rated operational voltage	$U_e$		500 V AC, 3-phase 600 V AC, 3-phase
Mains voltage (50/60Hz)	$U_{LN}$	V	500 (-10%) - 600 (+10%)
Input current (150% overload)	$I_{LN}$	A	12.2
System configuration			AC supply systems with earthed center point
Supply frequency	$f_{LN}$	Hz	50/60
Frequency range	$f_{LN}$	Hz	48 - 62
Mains switch-on frequency			Maximum of one time every 30 seconds
<b>Power section</b>			
Function			Variable frequency drive with internal DC link and IGBT inverter
Overload current (150% overload)	$I_L$	A	13.5
max. starting current (High Overload)	$I_H$	%	200
Note about max. starting current			for 4 seconds every 40 seconds
Output voltage with $V_e$	$U_2$		500 V AC, 3-phase 600 V AC, 3-phase
Output Frequency	$f_2$	Hz	0 - 50/60 (max. 500)
Switching frequency	$f_{PWM}$	kHz	8 adjustable 4 - 24 (audible)
Operation Mode			U/f control Speed control with slip compensation sensorless vector control (SLV) optional: Vector control with feedback (CLV)
Frequency resolution (setpoint value)	$\Delta f$	Hz	0.1
<b>Rated operational current</b>			
At 150% overload	$I_e$	A	9
Note			Rated operational current at a switching frequency of 8 kHz and an ambient air temperature of +50 °C
<b>Power loss</b>			
Heat dissipation at rated operational current $I_e = 150\%$	$P_V$	W	165
Efficiency	$\eta$	%	97
Maximum leakage current to ground (PE) without motor	$I_{PE}$	mA	9
Fitted with			Brake chopper 7-digital display assembly Additional PCB protection
Safety function			STO (Safe Torque Off, SIL2, PLd Cat 3)
Frame size			FS2
<b>Motor feeder</b>			
Note			for normal internally and externally ventilated 4 pole, three-phase asynchronous motors with $1500 \text{ rpm}^{-1}$ at 50 Hz or $1800 \text{ min}^{-1}$ at 60 Hz
Note			Overload cycle for 60 s every 600 s
Note			at 500 V, 50 Hz
150 % Overload	P	kW	5.5
Note			at 525 V, 50 Hz
150 % Overload	P	kW	5.5
Note			at 550 - 600 V, 60 Hz
150 % Overload	P	HP	7.5
maximum permissible cable length	l	m	screened: 100 screened, with motor choke: 200

			unscreened: 150 unscreened, with motor choke: 300
Apparent power			
Apparent power at rated operation 600 V	S	kVA	9.35
Braking function			
Standard braking torque			max. 30 % $M_N$
DC braking torque			max. 100% of rated operational current $I_e$ , variable
Braking torque with external braking resistance			Max. 100% of rated operational current $I_e$ with external braking resistor
minimum external braking resistance	$R_{min}$	$\Omega$	50
Switch-on threshold for the braking transistor	$U_{DC}$	V	975 V DC

### Control section

External control voltage	$U_c$	V	24 V DC (max. 100 mA)
Reference voltage	$U_s$	V	10 V DC (max. 10 mA)
Analog inputs			2, parameterizable, 0 - 10 V DC, 0/4 - 20 mA
Analog outputs			2, parameterizable, 0 - 10 V, 0/4 - 20 mA
Digital inputs			3, parameterizable, max. 30 VDC, max. 5 for non-parameterized analog inputs
Digital outputs			2, parameterizable, 24 V DC
Relay outputs			2, parameterizable, 1 N/O and 1 changeover contact, 6 A (250 V, AC-1) / 5 A (30 V, DC-1)
Interface/field bus (built-in)			OP-Bus (RS485)/Modbus RTU, CANopen <sup>®</sup>

### Assigned switching and protective elements

Power Wiring			
Safety device (fuse or miniature circuit-breaker)			
IEC (Type B, gG), 150 %			16NHG000B
Notes			NH fuse used together with TB00-D fuse base
UL (Class CC or J)		A	20
Notes			LPJ fuse used together with J60060-3 fuse base
UL (Class CC or J)		A	LPJ-15SP
Mains contactor			
150 % overload (CT/I <sub>H</sub> , at 50 °C)			DILM7
Main choke			
150 % overload (CT/I <sub>H</sub> , at 50 °C)			DX-LN3-016
DC link connection			
Braking resistance			
10 % duty factor (DF)			DX-BR100-0K8
20 % duty factor (DF)			DX-BR100-1K4
Motor feeder			
motor choke			
150 % overload (CT/I <sub>H</sub> , at 50 °C)			DX-LM3-011
Sine filter			
150 % overload (CT/I <sub>H</sub> , at 50 °C)			SIN-0014-6-0-P

### Design verification as per IEC/EN 61439

Technical data for design verification			
Rated operational current for specified heat dissipation	$I_n$	A	9
Heat dissipation per pole, current-dependent	$P_{vid}$	W	0
Equipment heat dissipation, current-dependent	$P_{vid}$	W	165
Static heat dissipation, non-current-dependent	$P_{vs}$	W	0
Heat dissipation capacity	$P_{diss}$	W	0
Operating ambient temperature min.		°C	-10
Operating ambient temperature max.		°C	50
			Operation (with 150 % overload)
IEC/EN 61439 design verification			
10.2 Strength of materials and parts			
10.2.2 Corrosion resistance			Meets the product standard's requirements.

10.2.3.1 Verification of thermal stability of enclosures		Meets the product standard's requirements.
10.2.3.2 Verification of resistance of insulating materials to normal heat		Meets the product standard's requirements.
10.2.3.3 Verification of resistance of insulating materials to abnormal heat and fire due to internal electric effects		Meets the product standard's requirements.
10.2.4 Resistance to ultra-violet (UV) radiation		Meets the product standard's requirements.
10.2.5 Lifting		Does not apply, since the entire switchgear needs to be evaluated.
10.2.6 Mechanical impact		Does not apply, since the entire switchgear needs to be evaluated.
10.2.7 Inscriptions		Meets the product standard's requirements.
10.3 Degree of protection of ASSEMBLIES		Does not apply, since the entire switchgear needs to be evaluated.
10.4 Clearances and creepage distances		Meets the product standard's requirements.
10.5 Protection against electric shock		Does not apply, since the entire switchgear needs to be evaluated.
10.6 Incorporation of switching devices and components		Does not apply, since the entire switchgear needs to be evaluated.
10.7 Internal electrical circuits and connections		Is the panel builder's responsibility.
10.8 Connections for external conductors		Is the panel builder's responsibility.
10.9 Insulation properties		
10.9.2 Power-frequency electric strength		Is the panel builder's responsibility.
10.9.3 Impulse withstand voltage		Is the panel builder's responsibility.
10.9.4 Testing of enclosures made of insulating material		Is the panel builder's responsibility.
10.10 Temperature rise		The panel builder is responsible for the temperature rise calculation. Eaton will provide heat dissipation data for the devices.
10.11 Short-circuit rating		Is the panel builder's responsibility. The specifications for the switchgear must be observed.
10.12 Electromagnetic compatibility		Is the panel builder's responsibility. The specifications for the switchgear must be observed.
10.13 Mechanical function		The device meets the requirements, provided the information in the instruction leaflet (IL) is observed.

## Technical data ETIM 7.0

Low-voltage industrial components (EG000017) / Frequency converter <= 1 kV (EC001857)		
Electric engineering, automation, process control engineering / Electrical drive / Static frequency converter / Static frequency converter = < 1 kV (ecl@ss10.0.1-27-02-31-01 [AKE177014])		
Mains voltage	V	500 - 600
Mains frequency		50/60 Hz
Number of phases input		3
Number of phases output		3
Max. output frequency	Hz	500
Max. output voltage	V	600
Nominal output current I2N	A	9
Max. output at quadratic load at rated output voltage	kW	5.5
Max. output at linear load at rated output voltage	kW	5.5
Relative symmetric net frequency tolerance	%	10
Relative symmetric net voltage tolerance	%	10
Number of analogue outputs		2
Number of analogue inputs		2
Number of digital outputs		2
Number of digital inputs		5
With control unit		Yes
Application in industrial area permitted		Yes
Application in domestic- and commercial area permitted		No
Supporting protocol for TCP/IP		No
Supporting protocol for PROFIBUS		Yes
Supporting protocol for CAN		Yes
Supporting protocol for INTERBUS		No
Supporting protocol for ASI		No
Supporting protocol for KNX		No
Supporting protocol for MODBUS		Yes
Supporting protocol for Data-Highway		No
Supporting protocol for DeviceNet		Yes

Supporting protocol for SUCONET			No
Supporting protocol for LON			No
Supporting protocol for PROFINET IO			Yes
Supporting protocol for PROFINET CBA			No
Supporting protocol for SERCOS			No
Supporting protocol for Foundation Fieldbus			No
Supporting protocol for EtherNet/IP			Yes
Supporting protocol for AS-Interface Safety at Work			No
Supporting protocol for DeviceNet Safety			No
Supporting protocol for INTERBUS-Safety			No
Supporting protocol for PROFIsafe			No
Supporting protocol for SafetyBUS p			No
Supporting protocol for BACnet			No
Supporting protocol for other bus systems			Yes
Number of HW-interfaces industrial Ethernet			0
Number of interfaces PROFINET			0
Number of HW-interfaces RS-232			0
Number of HW-interfaces RS-422			0
Number of HW-interfaces RS-485			1
Number of HW-interfaces serial TTY			0
Number of HW-interfaces USB			0
Number of HW-interfaces parallel			0
Number of HW-interfaces other			0
With optical interface			No
With PC connection			Yes
Integrated breaking resistance			Yes
4-quadrant operation possible			No
Type of converter			U converter
Degree of protection (IP)			IP20
Degree of protection (NEMA)			Other
Height		mm	231
Width		mm	107
Depth		mm	186

## Approvals

Product Standards			UL 508C; CSA-C22.2 No. 14; IEC/EN61800-3; IEC/EN61800-5; CE marking
UL File No.			E172143
UL Category Control No.			NMMS, NMMS7
CSA File No.			UL report applies to both US and Canada
North America Certification			UL listed, certified by UL for use in Canada
Specially designed for North America			No
Suitable for			Branch circuits
Max. Voltage Rating			3~ 600 V AC (+10 %) IEC: TN-S UL/CSA: "Y" (Solidly Grounded Wey)
Degree of Protection			IEC: IP20

## Dimensions

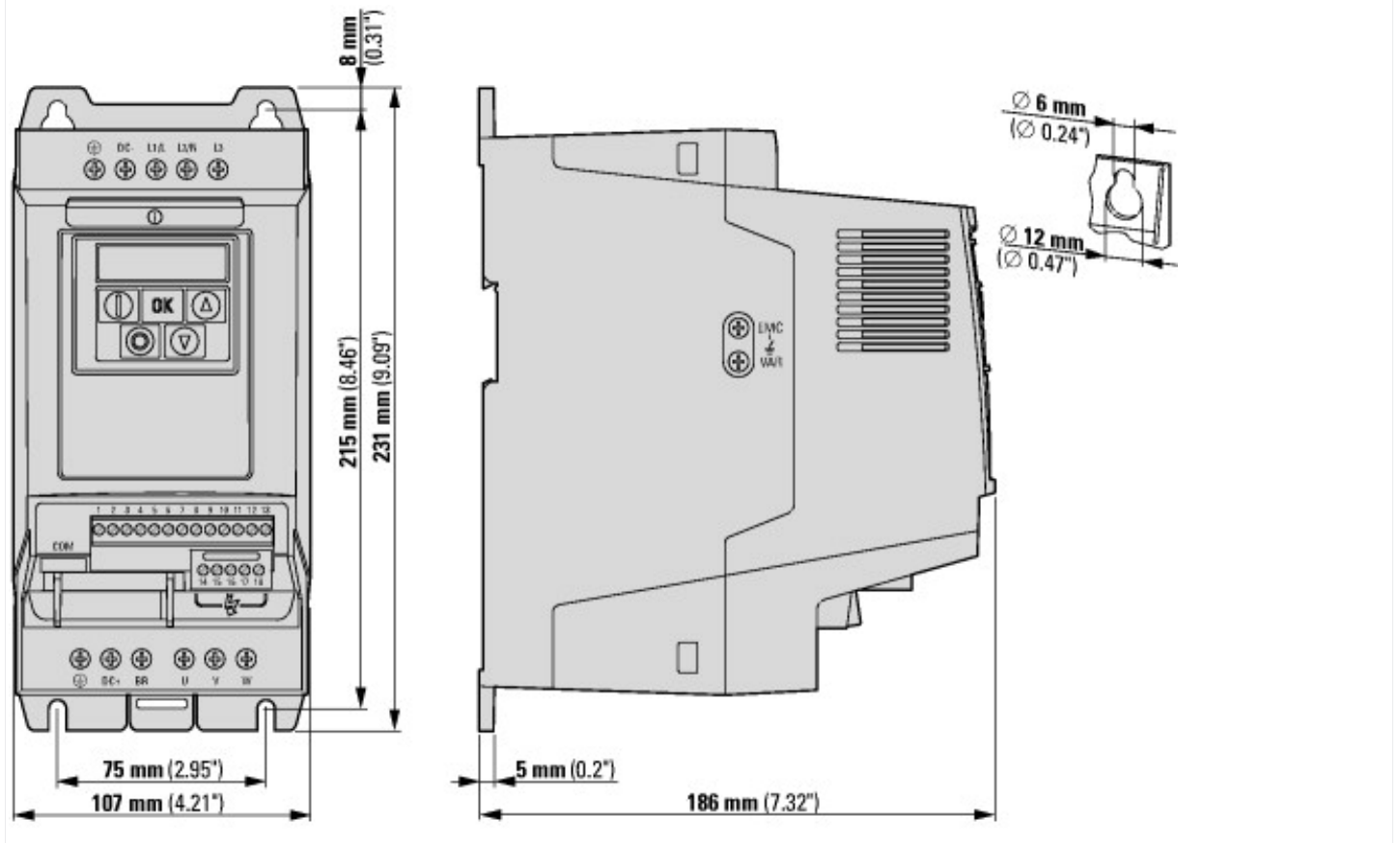

## Assets (links)

### Declaration of CE Conformity

00003239

### Instruction Leaflets

IL04020010Z2018\_04

### Manuals

MN04020005Z\_EN (English)

MN04020006Z\_EN (English)

## Additional product information (links)

### IL04020010Z DA1 variable frequency drives (FS2 - FS3, IP20)

IL04020010Z DA1 variable frequency drives (FS2 ftp://ftp.moeller.net/DOCUMENTATION/AWA\_INSTRUCTIONS/IL04020010Z2018\_04.pdf - FS3, IP20)

### MN04020005Z DA1 variable frequency drives, Installation manual

MN04020005Z Frequenzumrichter DA1, Installationshandbuch - Deutsch ftp://ftp.moeller.net/DOCUMENTATION/AWB\_MANUALS/MN04020005Z\_DE.pdf

MN04020005Z DA1 variable frequency drives, Installation manual - English ftp://ftp.moeller.net/DOCUMENTATION/AWB\_MANUALS/MN04020005Z\_EN.pdf

MN04020005Z Convertitore di frequenza DA1, manuale Installazione - italiano ftp://ftp.moeller.net/DOCUMENTATION/AWB\_MANUALS/MN04020005Z\_IT.pdf

### MN04020006Z DA1 variable frequency drives, Parameters manual

MN04020006Z Frequenzumrichter DA1, Parameterhandbuch - Deutsch ftp://ftp.moeller.net/DOCUMENTATION/AWB\_MANUALS/MN04020006Z\_DE.pdf

MN04020006Z DA1 variable frequency drives, Parameters manual - English ftp://ftp.moeller.net/DOCUMENTATION/AWB\_MANUALS/MN04020006Z\_EN.pdf

MN04020006Z Convertitore di frequenza DA1, manuale Parametri - italiano ftp://ftp.moeller.net/DOCUMENTATION/AWB\_MANUALS/MN04020006Z\_IT.pdf

CA04020001Z-EN Product Range Catalog: Efficient Engineering for Starting and Controlling Motors http://www.eaton.eu/DE/ecm/groups/public/@pub/@europe/@electrical/documents/content/pct\_1095238.pdf