

DATASHEET - P3-63/ST/SVB



Main switch, +steel enclosure, 3p, 63A, handle red yellow, lockable



Part no. P3-63/ST/SVB
Catalog No. 025521

Dimensions

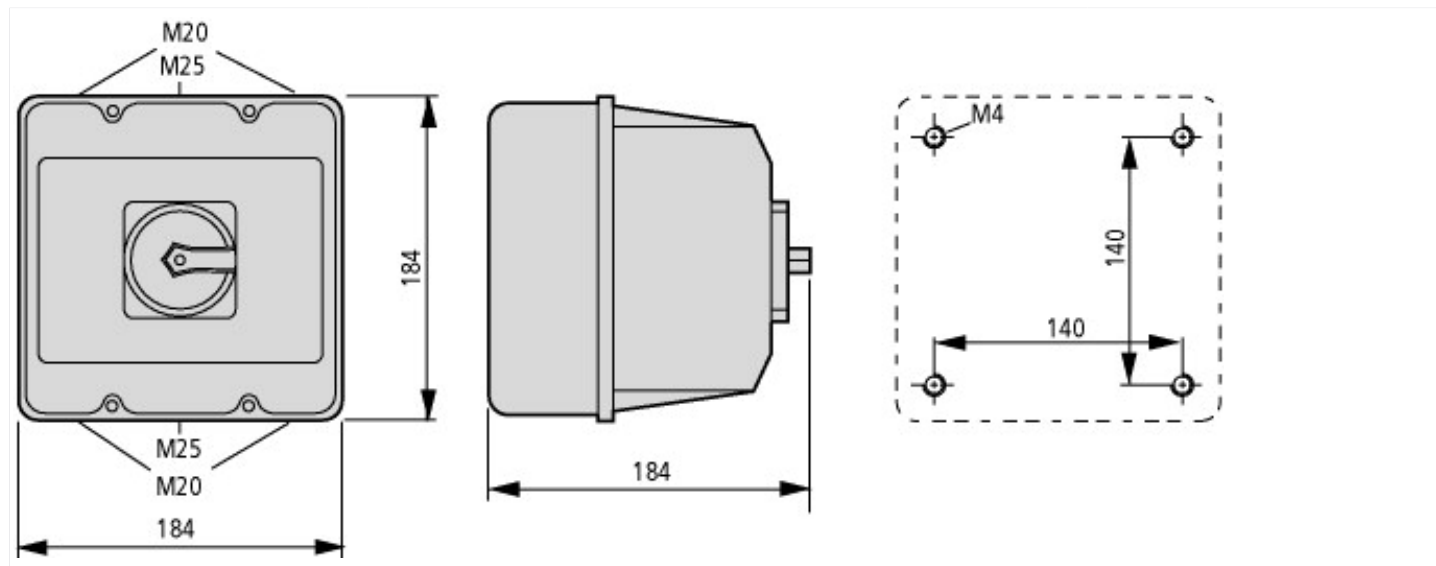

Assets (links)

Declaration of CE Conformity

00003104

Instruction Leaflets

IL03802007Z2018_05