

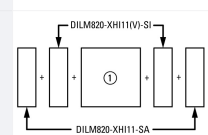

DC contactor, 2-pole + 2 N/O + 2 N/C, 600 A/DC-1, 1000v

Part no. DILDC600/22(RDS250)
Catalog No. 183315
Alternate Catalog No. XTCE600DCM22A

Delivery program

Product range			Contactors
Application			DC contactor
Subrange			Comfort devices greater than 170 A
Instructions			DILDC contactors feature an electronic arc suppression system. Because of this, it is important not to exceed any technical data limits in general – especially the making and breaking capacity limits. Opening the device will immediately void the warranty.
Rated operational current, open			
DC-1			
Notes			I _e at 60 °C
1000 V	I _e	A	600
Can be combined with auxiliary contact			DILM820-XHI...
Actuating voltage			RDS 250: 110 - 250 V 40 - 60 Hz/110 - 350 V DC
Voltage AC/DC			AC and DC operation
Contacts			
N/O = Normally open			2 N/O
N/C = Normally closed			2 NC
Auxiliary contacts			
possible variants at auxiliary contact module fitting options			on the side: 2 x DILM820-XHI11(V)-SI; 2 x DILM820-XHI11-SA
Side mounting auxiliary contacts			

Technical data

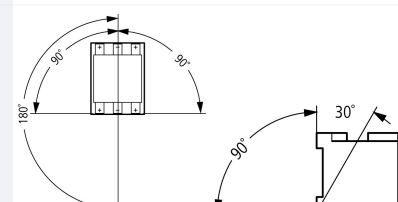
General			
Standards			EN60947-4-1, EN60947-5-1
Lifespan, mechanical			
AC operated	Operations	x 10 ⁶	1
DC operated	Operations	x 10 ⁶	1
Operating frequency, mechanical			
AC operated	Operations/h		1000
DC operated	Operations/h		1000
Maximum operating frequency			
electrical (Contactors without overload relay)	Operations/h		100
Climatic proofing			Damp heat, constant, to IEC 60068-2-78 Damp heat, cyclic, to IEC 60068-2-30
Ambient temperature			
Open		°C	-40 - +70
Enclosed		°C	-40 - +40
Storage		°C	-40 - +80
Mounting position			

Mechanical shock resistance (IEC/EN 60068-2-27)			
Half-sinusoidal shock, 10 ms			
Main contacts			
N/O contact		g	10
Auxiliary contacts			
N/O contact		g	10
N/C contact		g	8
Degree of Protection			IP00
Protection against direct contact when actuated from front (EN 50274)			Covers on main terminals safeguarded against accidental contact with fingers or back of hand
Weight			
Weight		kg	7.5
Terminal capacity main cable			
Flexible with cable lug		mm ²	50 - 240
Stranded with cable lug		mm ²	50 - 240
Solid or stranded		AWG	1/0 - 500 MCM
Busbar	Width	mm	40
Main cable connection screw/bolt			M10
Tightening torque			Nm 24
Terminal capacity control circuit cables			
Solid		mm ²	1 x (0.75 - 2.5) 2 x (0.75 - 2.5)
Flexible with ferrule		mm ²	1 x (0.75 - 2.5) 2 x (0.75 - 2.5)
Solid or stranded		AWG	2 x (18 - 12)
Control circuit cable connection screw/bolt			M3.5
Tightening torque			Nm 1.2
Tool			
Main cable			
Width across flats		mm	16
Control circuit cables			
Pozidriv screwdriver		Size	2
Standard screwdriver		mm	0.8 x 5.5 1 x 6

Main conducting paths

Rated impulse withstand voltage	U_{imp}	V	8000
Overvoltage category/pollution degree			III/3
Rated insulation voltage	U_i	V DC	1000
Rated operational voltage	U_e	V DC	1000
Safe isolation to EN 61140			
Between control inputs and main contacts		V	1000
Between auxiliary contacts and main contacts		V	1000
between the contacts		V	1000
Making capacity			A 900
Breaking capacity			
220 V 230 V		A	900
380 V 400 V		A	900
500 V		A	900
660 V 690 V		A	900
1000 V		A	900
Short-circuit rating			
Short-circuit protection maximum fuse			
Type "2" coordination			
400 V DC	gR 1000 VDC	A	900 (max. short-circuit current 6 kA)
690 V DC	gR 1000 VDC	A	900 (max. short-circuit current 6 kA)
1000 V DC	gR 1000 VDC	A	900 (max. short-circuit current 6 kA)

Type "1" coordination			
400 V DC	gR 1000 VDC	A	900 (max. short-circuit current 30 kA)
690 V DC	gR 1000 VDC	A	900 (max. short-circuit current 30 kA)
1000 V DC	gR 1000 VDC	A	900 (max. short-circuit current 30 kA)

DC

Rated operational current, open			
DC-1			
Notes			I_e at 60 °C
1000 V	I_e	A	600

Current heat loss

1 pole, at I_{th}		W	72
---------------------	--	---	----

Magnet systems

Voltage tolerance			
U_S			110 - 250 V 40-60 Hz 110 - 350 V DC
AC operated	Pick-up	$x U_S$	$0.7 \times U_{S \min} - 1.15 \times U_{S \max}$
DC operated	Pick-up	$x U_S$	$0.7 \times U_{S \min} - 1.15 \times U_{S \max}$
AC operated	Drop-out	$x U_S$	$0.2 \times U_{S \max} - 0.6 \times U_{S \min}$
DC operated	Drop-out	$x U_S$	$0.2 \times U_{S \max} - 0.6 \times U_{S \min}$
Actuation directly from PLC			
U_C			24 V DC
$U_C \min - \max$			15 - 31,2 V DC
Power consumption of the coil in a cold state and $1.0 \times U_S$			
Note on power consumption			Control transformer with $u_k \leq 6\%$
Pull-in power	Pick-up	VA	600
Pull-in power	Pick-up	W	550
Sealing power	Sealing	VA	18
Sealing power	Sealing	W	9.5
Duty factor		% DF	100
Changeover time at 100 % U_S (recommended value)			
Main contacts			
Closing delay		ms	80
Opening delay		ms	40
PLC signal level (A3 - A4) to IEC/EN 61131-2 (type 2)			
High		V	15
Low		V	5

Electromagnetic compatibility (EMC)

Electromagnetic compatibility			This product is designed for operation in industrial environments (environment A). Its use in residential environments (environment B) may cause radio-frequency interference, requiring additional noise suppression measures.
-------------------------------	--	--	---

Rating data for approved types

Switching capacity			
Maximum motor rating			
Single-phase			
General use		A	600
Auxiliary contacts			
Pilot Duty			
AC operated			A600
DC operated			P300
General Use			
AC		V	600
AC		A	15
DC		V	250
DC		A	1

Design verification as per IEC/EN 61439

Technical data for design verification			
--	--	--	--

Rated operational current for specified heat dissipation	I_n	A	600
Heat dissipation per pole, current-dependent	P_{vid}	W	72
Equipment heat dissipation, current-dependent	P_{vid}	W	0
Static heat dissipation, non-current-dependent	P_{vs}	W	9
Heat dissipation capacity	P_{diss}	W	0
Operating ambient temperature min.		°C	-40
Operating ambient temperature max.		°C	70
IEC/EN 61439 design verification			
10.2 Strength of materials and parts			
10.2.2 Corrosion resistance			Meets the product standard's requirements.
10.2.3.1 Verification of thermal stability of enclosures			Meets the product standard's requirements.
10.2.3.2 Verification of resistance of insulating materials to normal heat			Meets the product standard's requirements.
10.2.3.3 Verification of resistance of insulating materials to abnormal heat and fire due to internal electric effects			Meets the product standard's requirements.
10.2.4 Resistance to ultra-violet (UV) radiation			Meets the product standard's requirements.
10.2.5 Lifting			Does not apply, since the entire switchgear needs to be evaluated.
10.2.6 Mechanical impact			Does not apply, since the entire switchgear needs to be evaluated.
10.2.7 Inscriptions			Meets the product standard's requirements.
10.3 Degree of protection of ASSEMBLIES			Does not apply, since the entire switchgear needs to be evaluated.
10.4 Clearances and creepage distances			Meets the product standard's requirements.
10.5 Protection against electric shock			Does not apply, since the entire switchgear needs to be evaluated.
10.6 Incorporation of switching devices and components			Does not apply, since the entire switchgear needs to be evaluated.
10.7 Internal electrical circuits and connections			Is the panel builder's responsibility.
10.8 Connections for external conductors			Is the panel builder's responsibility.
10.9 Insulation properties			
10.9.2 Power-frequency electric strength			Is the panel builder's responsibility.
10.9.3 Impulse withstand voltage			Is the panel builder's responsibility.
10.9.4 Testing of enclosures made of insulating material			Is the panel builder's responsibility.
10.10 Temperature rise			The panel builder is responsible for the temperature rise calculation. Eaton will provide heat dissipation data for the devices.
10.11 Short-circuit rating			Is the panel builder's responsibility. The specifications for the switchgear must be observed.
10.12 Electromagnetic compatibility			Is the panel builder's responsibility. The specifications for the switchgear must be observed.
10.13 Mechanical function			The device meets the requirements, provided the information in the instruction leaflet (IL) is observed.

Technical data ETIM 7.0

Low-voltage industrial components (EG000017) / Power contactor, DC switching (EC002552)			
Electric engineering, automation, process control engineering / Low-voltage switch technology / Contactor (LV) / Power contactor, d.c. switching (ecl@ss10.0.1-27-37-10-18 [ACN974011])			
Rated control supply voltage U_s at AC 50HZ		V	110 - 250
Rated control supply voltage U_s at AC 60HZ		V	110 - 250
Rated control supply voltage U_s at DC		V	110 - 350
Voltage type for actuating			AC/DC
Rated operation power at DC-3 / DC-5 at 440 V		kW	0
Rated operation current I_e at DC-3 / DC-5 at 440 V		A	0
Modular version			No
Number of auxiliary contacts as normally open contact			2
Number of auxiliary contacts as normally closed contact			2
Type of electrical connection of main circuit			Connection rail
Number of normally closed contacts as main contact			0
Number of main contacts as normally open contact			2

Approvals

Product Standards			IEC/EN 60947-4-1; UL508; CSA-C22.2 No. 14-05; CE marking
UL File No.			E338590
UL Category Control No.			NRNT

Characteristics

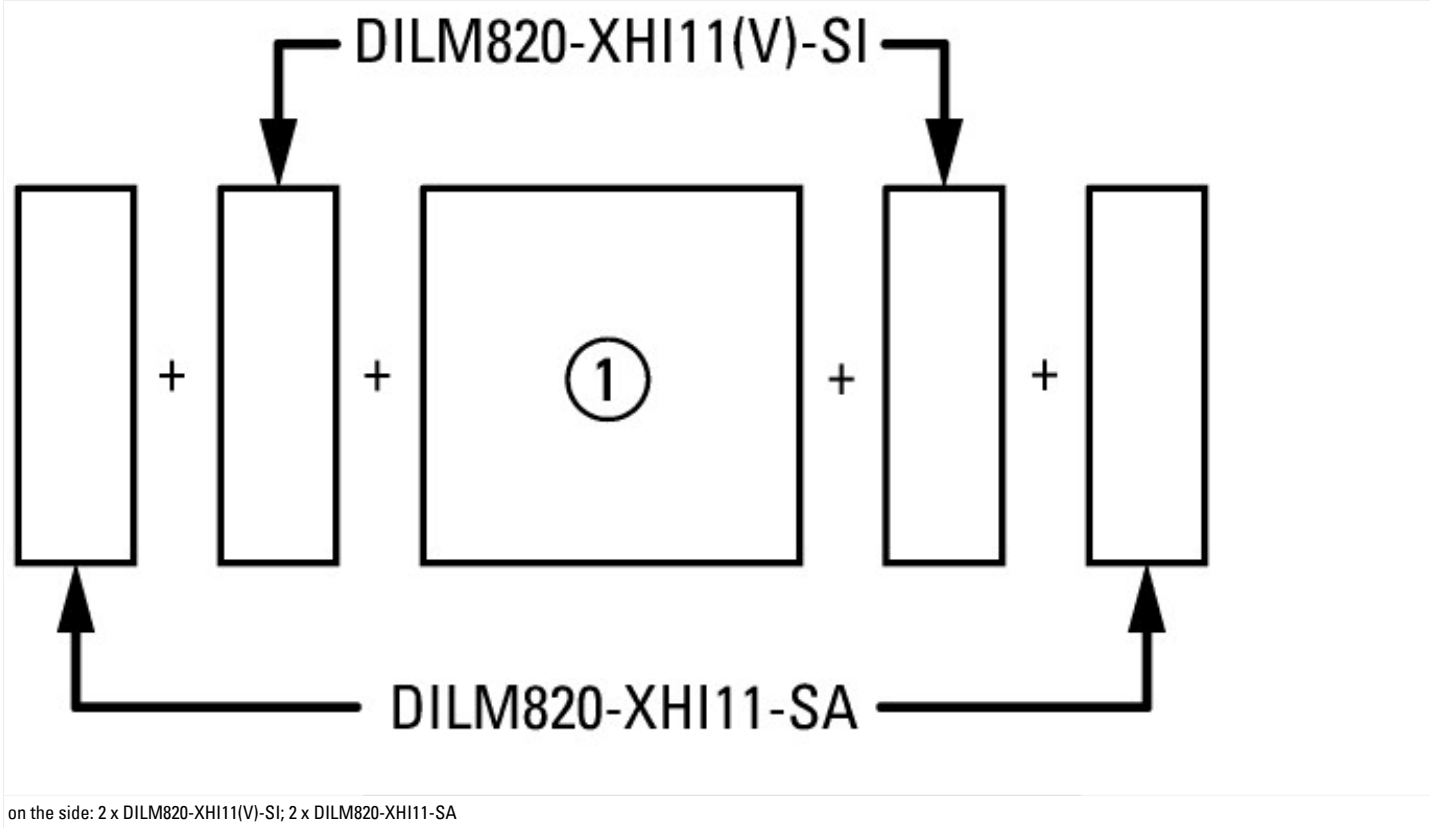

Dimensions

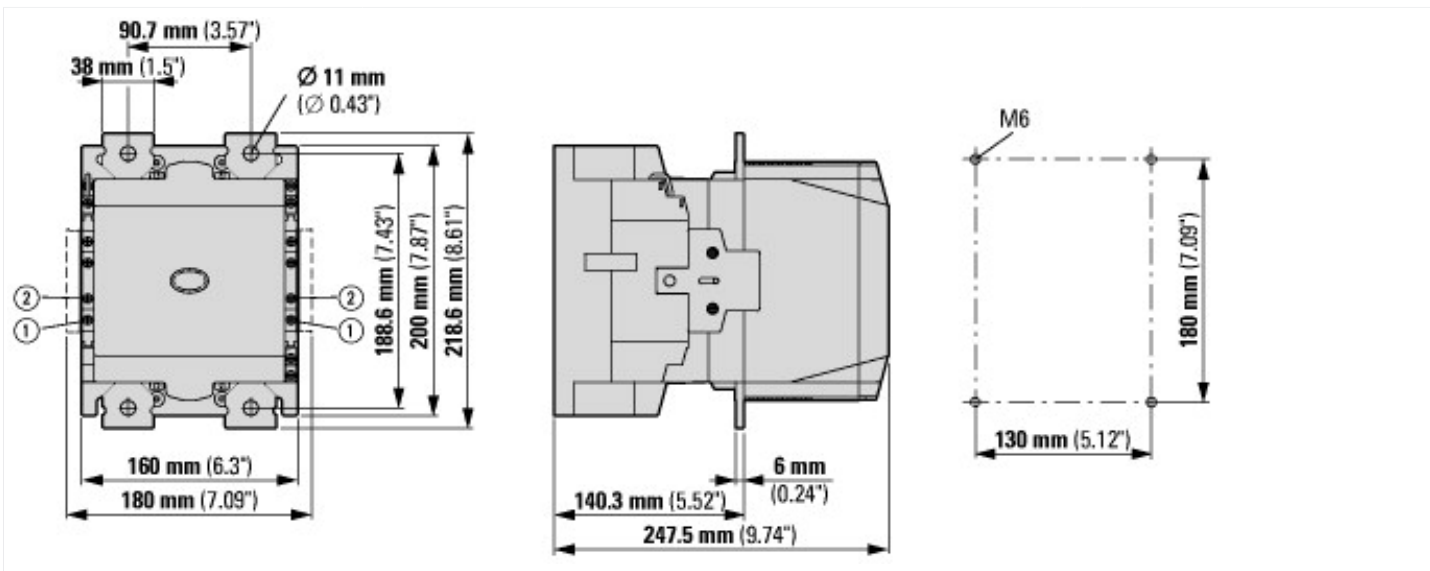

Assets (links)

Declaration of CE Conformity

00002861

Instruction Leaflets

IL034035ZU2018_08

Additional product information (links)

IL034035ZU DC contactors

IL034035ZU DC contactors

ftp://ftp.moeller.net/DOCUMENTATION/AWA_INSTRUCTIONS/IL034035ZU2018_05.pdf

Motor starters and "Special Purpose Ratings" for the North American market

http://www.eaton.eu/ecm/groups/public/@pub/@europe/@electrical/documents/content/pct_3258146.pdf

Switchgear of Power Factor Correction Systems	http://www.moeller.net/binary/ver_techpapers/ver934en.pdf
X-Start - Modern Switching Installations Efficiently Fitted and Wired Securely	http://www.moeller.net/binary/ver_techpapers/ver938en.pdf
Mirror Contacts for Highly-Reliable Information Relating to Safety-Related Control Functions	http://www.moeller.net/binary/ver_techpapers/ver944en.pdf
Effect of the Cabel Capacitance of Long Control Cables on the Actuation of Contactors	http://www.moeller.net/binary/ver_techpapers/ver949en.pdf
Switchgear for Luminaires	http://www.moeller.net/binary/ver_techpapers/ver955en.pdf
Standard Compliant and Functionally Safe Engineering Design with Mechanical Auxiliary Contacts	http://www.moeller.net/binary/ver_techpapers/ver956en.pdf
The Interaction of Contactors with PLCs	http://www.moeller.net/binary/ver_techpapers/ver957en.pdf
Busbar Component Adapters for modern Industrial control panels	http://www.moeller.net/binary/ver_techpapers/ver960en.pdf