



Power supply unit, 3-phase, 400-500VAC/24VDC, 2.5A

Part no. PSG60F
Article no. 135226

Delivery programme

Product range			Power supplies PSG
Phases			3-phase
Input voltage range			320 - 575 V AC 450 - 800 V DC
Nominal input voltage			3 x 400 - 500 V AC
Rated output voltage			24 V DC (± 2%)
Rated output current		A	2.5
Setting range for the output voltage			22-28 V DC
Rated output power		W	60

Technical data

Input characteristics

Nominal input voltage			3 x 400 - 500 V AC
Supply frequency			
Rated value		Hz	50/60
Range		Hz	47 - 63
Nominal current	I_n	A	0.3 bei 400 V AC
Mains buffering at nominal load		ms	
Mains failure bridging		ms	> 30 at 3 x 400 V AC > 60 at 3 x 500 V AC
Run-up time after mains voltage applied		ms	2000
Internal input fuse (device protection, not accessible)			3.15AH/500 V
Back-up fuse			3 x 6, 10, 16 A (recommended)
Tripping characteristic			B
Leakage Current			< 3.5 mA

Output characteristics

Rated output power		W	60
Rated output voltage			24 V DC (± 2%)
Tolerance			±2 %
Setting range for the output voltage			22-28 V DC
Nominal current		A	2,5
Derating from $T_{amb} > +50\text{ °C}$			2.5 % per Kelvin temperature increase
Capacitive load starting			Max 10000 µF
Heat dissipation		W	9
Efficiency		%	> 86 at 3 x 400 V AC > 85 at 3 x 500 V AC
Residual ripple and switching peaks			20 MHz: < 50 mV/< 240 mVpp
Can be switched in parallel			with ORing Diode

General characteristics

Housing			Aluminum (Al5052)
Status indication			DC OK: LED green
Height		mm	121
Width		mm	70
Depth		mm	118.5
Weight		kg	0.56
Terminations			Screw connection
Stripping length		mm	7

			or suitable cable lug for crimping
Ambient air temperature range		°C	
Operation		°C	-20 - +75 (> 50 °C derating)
Storage, transport	θ	°C	
Storage	θ	°C	-20 - +85
damp heat			< 95 % relative humidity at +25 °C, no condensation
Vibrations (IEC/EN 60068-2-6)			10 – 150 Hz, accel. 50 m/s ² , 0.35 mm, single amplitude (5 g max.) for 90 min. in X, Y, Z direction
Mechanical shock resistance (IEC 60068-2-27)			30 g (300 m/s ²) in all directions
Pollution degree			2
Climatic class (IEC)			3K3 according to EN 60721

Safety and safety features

Transient overvoltage protection			Varistor
Current limitation at short-circuit			I _{Überstrom} = 150 % der max. Ausgangsleistung
Overvoltage protection			Yes, against internal overvoltage
Insulation voltage			
Input/Output			4 kV AC (type test), 3 kV AC (routine test)
Input/PE			1.5 kV AC (type test), 1.5 kV AC (routine test)
Output/PE			1.5 kV AC (type test), 500 V AC (routine test)
Degree of Protection			IPX0
Protection class			Class I with PE connection

Standards

			Electrical equipment of machines: IEC60204-1 (Overvoltage category III) Equipping power installations with electronic apparatus: EN 50178/IEC 62103 Safety extra-low voltage: PELV (EN 60204), SELV (EN 60950) Protection against electric shock: DIN 57100-410 CE: In conformance with EMC Directive 2004/108/EC and Low Voltage Directive 2006/95/EC ITE: EN 55022, EN 61000-3-2, EN 61000-3-3, EN 55024 Industrial: EN 55011 Mains harmonics limitation: EN 601000-3-2
--	--	--	--

Design verification as per IEC/EN 61439

IEC/EN 61439 design verification			
10.2 Strength of materials and parts			
10.2.2 Corrosion resistance			Meets the product standard's requirements.
10.2.3.1 Verification of thermal stability of enclosures			Meets the product standard's requirements.
10.2.3.2 Verification of resistance of insulating materials to normal heat			Meets the product standard's requirements.
10.2.3.3 Verification of resistance of insulating materials to abnormal heat and fire due to internal electric effects			Meets the product standard's requirements.
10.2.4 Resistance to ultra-violet (UV) radiation			Meets the product standard's requirements.
10.2.5 Lifting			Does not apply, since the entire switchgear needs to be evaluated.
10.2.6 Mechanical impact			Does not apply, since the entire switchgear needs to be evaluated.
10.2.7 Inscriptions			Meets the product standard's requirements.
10.3 Degree of protection of ASSEMBLIES			Meets the product standard's requirements.
10.4 Clearances and creepage distances			Meets the product standard's requirements.
10.5 Protection against electric shock			Does not apply, since the entire switchgear needs to be evaluated.
10.6 Incorporation of switching devices and components			Does not apply, since the entire switchgear needs to be evaluated.
10.7 Internal electrical circuits and connections			Is the panel builder's responsibility.
10.8 Connections for external conductors			Is the panel builder's responsibility.
10.9 Insulation properties			
10.9.2 Power-frequency electric strength			Is the panel builder's responsibility.
10.9.3 Impulse withstand voltage			Is the panel builder's responsibility.
10.9.4 Testing of enclosures made of insulating material			Is the panel builder's responsibility.
10.10 Temperature rise			The panel builder is responsible for the temperature rise calculation. Eaton will provide heat dissipation data for the devices.
10.11 Short-circuit rating			Is the panel builder's responsibility.
10.12 Electromagnetic compatibility			Is the panel builder's responsibility.
10.13 Mechanical function			The device meets the requirements, provided the information in the instruction leaflet (IL) is observed.

Dimensions

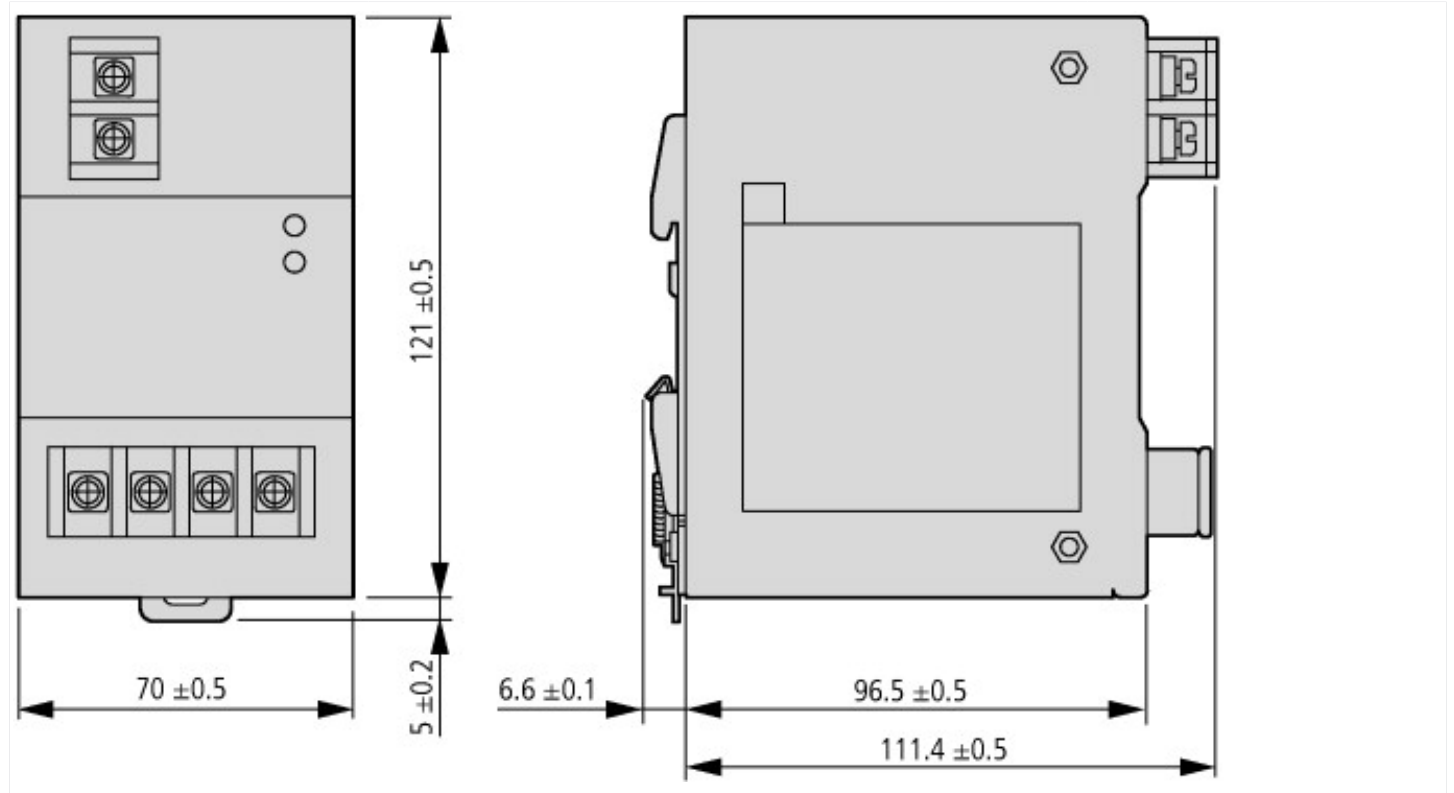

Additional product information (links)

IL00912005E

IL00912005E