

Data sheet

Rotary valves HFE 3

Description



Danfoss HFE rotary valves are primarily designed for regulation of flow temperature in heating systems where a certain leakage can be accepted and where a defined control characteristic is not required.

HFE rotary valves can be used in combination with electric actuators AMB 162 and AMB 182.

Features:

- Cast iron body with flange connection
- Lowest leakage in class
- Valve position indicator
- Ergonomic handle
- For mixing and diverting applications
- Flange PN 6 connection

Main data:

- DN 20–150
- k_{vs} 12–400 m³/h
- PN 6
- t_{max} 110 °C
- 3-way
- S characteristic

Ordering

Type	DN (mm)	k_{vs} (m ³ /h)	PN	Code No.
HFE 3	20	12	6	065Z0428
	25	18		065Z0429
	32	28		065Z0430
	40	44		065Z0431
	50	60		065Z0432
	65	90		065Z0433
	80	150		065Z0434
	100	225		065Z0435
	125	280		065Z0436
	150	400		065Z0437

Spare parts and accessories

Type	DN	Code No.
Replacement handle		065Z0443
Stuffing box and sealing	20-25	065Z0454
	32-40	065Z0455
	50-65	065Z0456
	80	065Z0457
	100-125	065Z0458
Linkage kit for AMB (Gen. 2014)	150	065Z0459
		082H0255

Technical data

Nominal diameter	DN	20	25	32	40	50	65	80	100	125	150	
k_{vs}	m ³ /h	12	18	28	44	60	90	150	225	280	400	
Control characteristic		S characteristic										
Leakage		Diverting: max. 0.75% of k_{vs} / Mixing: max. 1.5% of k_{vs}										
Nominal pressure	PN	6										
Max. closing pressure	bar	0.5										
Torque at PN	Nm	5					10			15		
Medium		Circulation water / glycolic mixture up to 50%										
Medium pH		Min. 7, max. 10										
Medium temperature	°C	2 ... 110										
Connections		Flanges PN 6										
Materials												
Valve body and cover		Grey cast iron EN-GJL-250 (GG25)										
Slide shoe		CuZn36Pb2As (BrassDZR, CW 602N)						Stainless steel, EN 1.4301 (304)				
Stuffing box sealing		EPDM										

Pressure temperature diagram

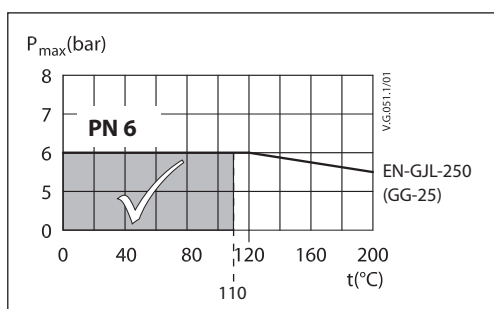

Installation

Valve mounting

Before valve mounting pipes have to be cleaned and free from abrasion. Mechanical loads on valve body caused by the pipes are not allowed. It is recommended to install a strainer into application to avoid damaging controlling components.

Connection

HFE 3 can be used as a mixing valve, diverting valve and in connection with heat exchangers where a certain leakage can be accepted.

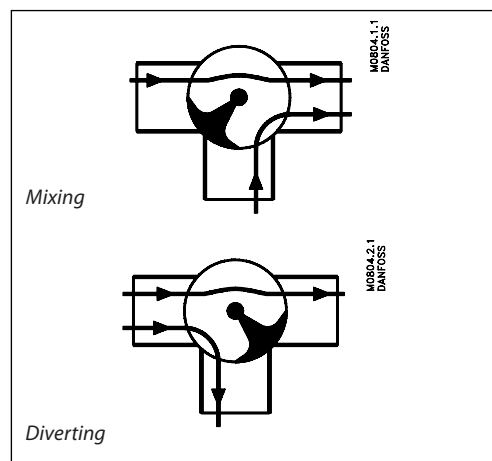

Note:

Install a strainer upstream of the valve (e.g. Danfoss FVR/FVF)

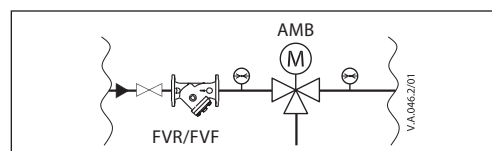

Disposal

The valve must be dismantled and the elements sorted into various material groups before disposal.

Application principles

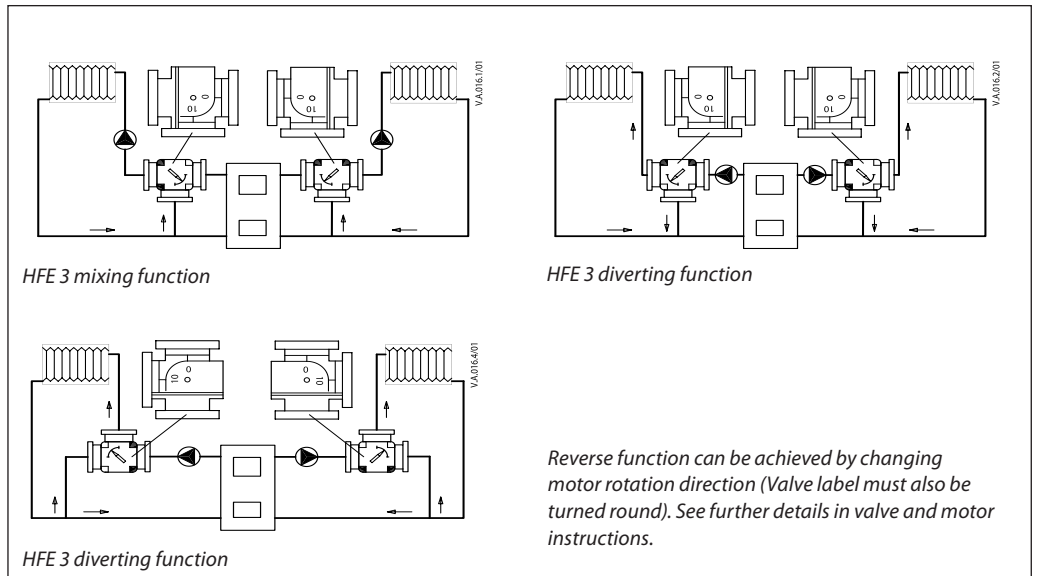

Sizing

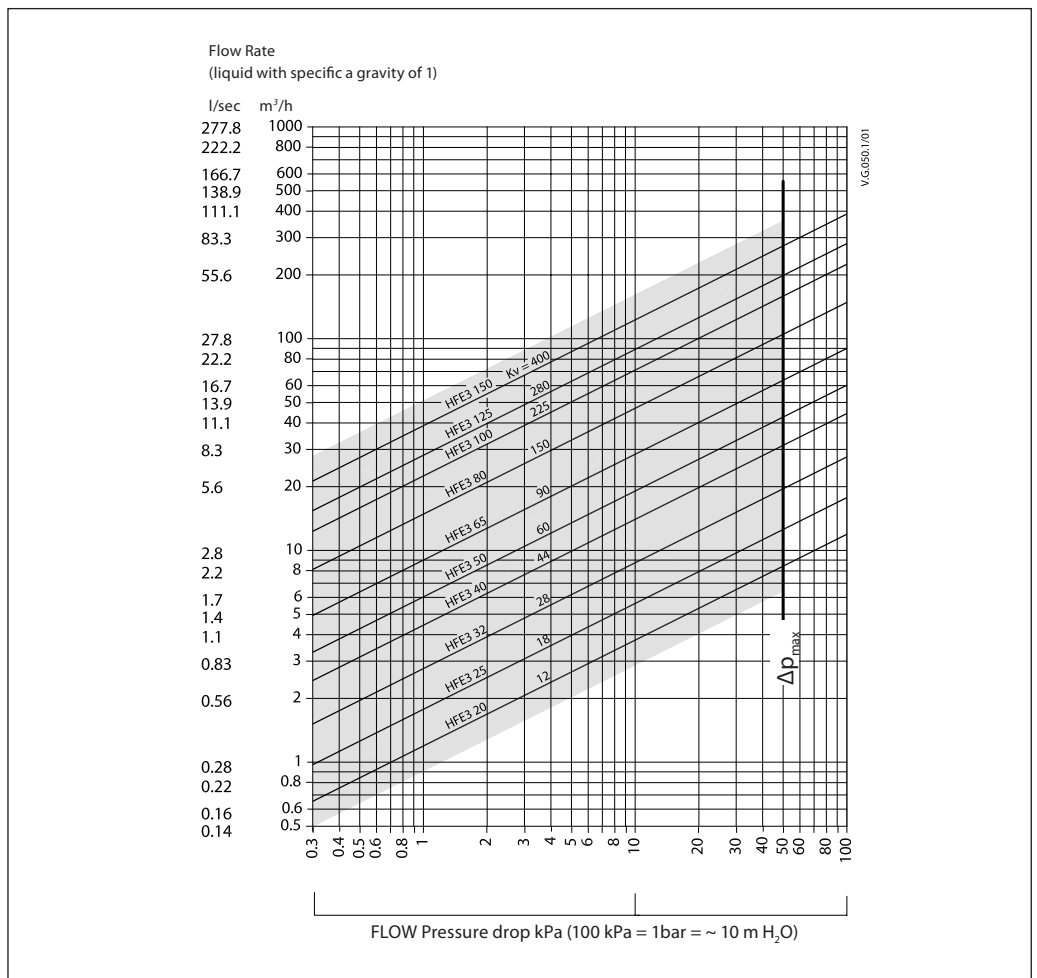

Data sheet

Rotary valves HFE 3

Design

- 1. Valve body
- 2. Slide shoe
- 3. Valve cover
- 4. Stuffing box
- 5. Handle

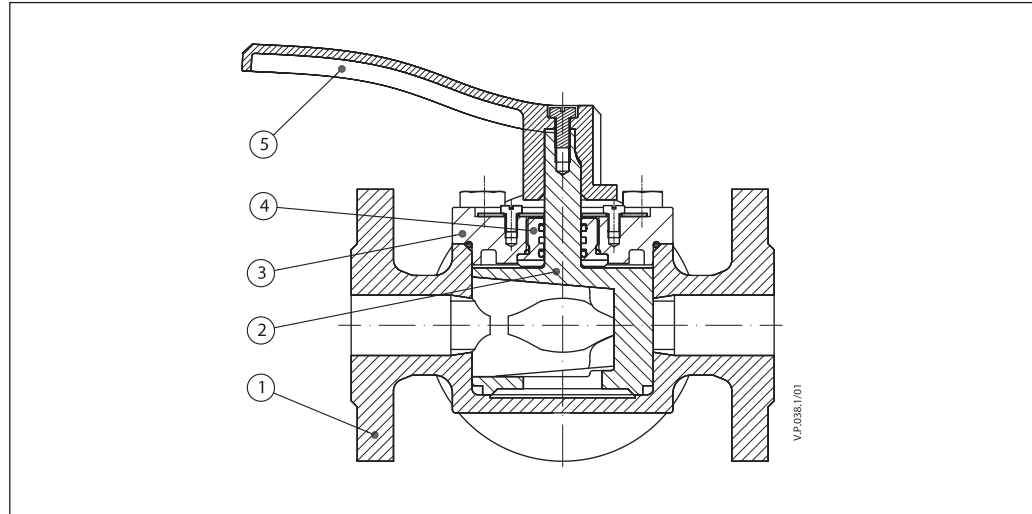

Dimensions

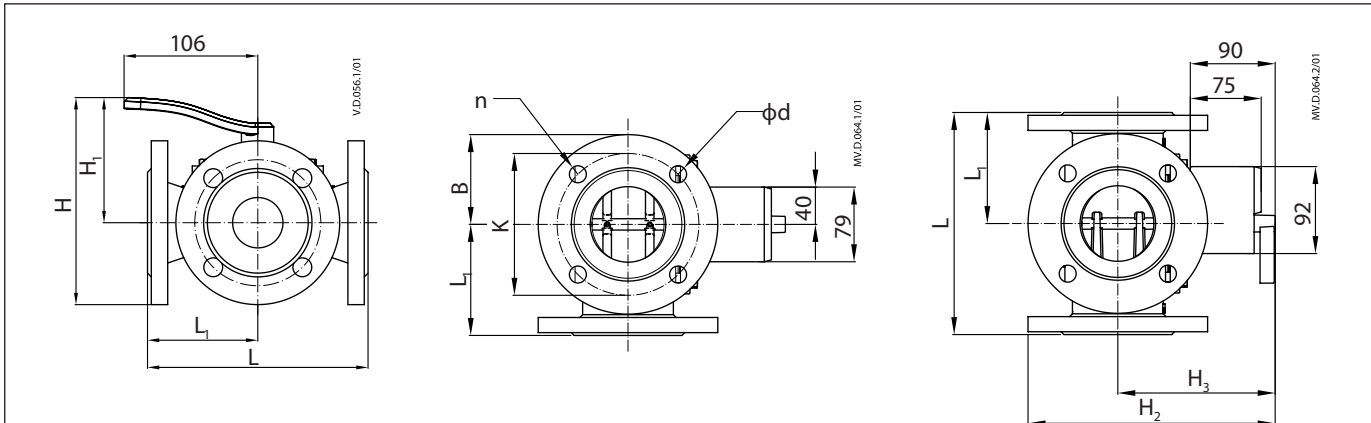

DN	H	H ₁	H ₂	H ₃	L	L ₁	B	K	φd	n	Weight (kg)	Actuator
	mm											
20	137	92	140	131	140	70	45	65	11.5	4	3.5	AMB 162 AMB 182
25	142	92	140	136	150	75	50	75	11.5	4	4.0	
32	158	98	152	146	160	80	60	90	15	4	6.6	
40	163	98	157	146	175	88	65	100	15	4	7.2	
50	177	107	171	155	195	98	70	110	15	4	9.4	
65	187	107	181	155	200	100	80	130	15	4	11.5	
80	215	120	208	167	235	118	95	150	18	4	17	
100	233	128	228	177	265	133	105	170	18	4	22.5	
125	259	139	253	187	300	150	120	200	18	8	29.5	
150	277	145	271	192	350	175	133	225	18	8	40.2	

Danfoss A/S

Heating Segment • heating.danfoss.com • +45 7488 2222 • E-Mail: heating@danfoss.com

Danfoss can accept no responsibility for possible errors in catalogues, brochures and other printed material. Danfoss reserves the right to alter its products without notice. This also applies to products already on order provided that such alterations can be made without subsequential changes being necessary in specifications already agreed. All trademarks in this material are property of the respective companies. Danfoss and all Danfoss logotypes are trademarks of Danfoss A/S. All rights reserved.