

Data sheet

# Pressure difference controller with integrated flow limiter AB-PM DN 40-100

Description



AB-PM is ideal for staged installation and commissioning

AB-PM is a combined balancing valve. It features 4 functions in one compact valve:

1. Differential pressure control
2. Flow limitation
3. Control valve with linear characteristic
4. Zone control

Reliable HVAC system with low total cost of ownership:

**Design:**

- Easy, fast and flexible HVAC system design

**Construction:**

- Fast installation and easy setting
- Lower commissioning cost - no need for balancing
- Faster project with staged handover

**Operation:**

- Perfect balance at all loads
- Guaranteed flow and  $\Delta p$  for users
- No problems caused by poor designed/ executed user installations
- Unoccupied zones do not impact other users
- Flow verification and easy troubleshooting

Ordering

AB-PM valve (including 2.5 m impulse tube (G 1/16 A), brass handle (003Z0695) impulse tube connector (003L8151))

Picture	DN	Connection	Code No.
	40	Ext thread (ISO228/1) G 2A	003Z1435
	50	Ext.thread (ISO228/1) G 2½A	003Z1436
	65	Flange PN 16	003Z1438
	80		003Z1439
	100		003Z1440

**Actuator**

Type	Power supply	Code No.
AME435 QM <sup>1)</sup>	24 VAC/DC	082H0171





<sup>1)</sup> For more information see AME 435 QM datasheet

**Accessories**

Picture	Type	To pipe	To valve	Code No.
	Union connection (CW617N) (1 pcs.)	R1½	DN40	003Z0279
		R2	DN50	003Z0278
	Tail piece welding (W.Nr. 10308)(1 pcs.)	Weld	DN40	003Z0270
			DN50	003Z0276
	Tailpiece welding INOX (W. Nr. 1.4404) (1 pcs.)	Weld	DN40	003Z1275
			DN50	003Z1276

Ordering

Spare parts

Type	Comments	Code No.
Handle AB-PM (brass handle for spindle fixation)	DN 40-100	003Z0695
Impulse tube, with O-rings	1.5 m	003L8152
	2.5 m	003Z0690
	5 m	003L8153
Plastic impulse tube with connectors and adapters (industry pack)	10 pcs order quantity	003Z0689
Adapter large 	G.-R.; G 1/16	003Z0691
Plug for connecting impulse tube 	3/8" – 1/16"	003L5042
	3/4" – 1/16"	003Z0109
	1/4" – 1/16	003L8151
Plug for connecting impulse tube on other valves (US standard)	G 1/16-4/16-20 UNF-2B	003L8176
O-ring for impulse tube (set of 10 pcs)	2.90 x 1.78	003L8175
Plug for impulse tube connection ASV-I/M (set of 10 pcs) 	G1/16 A	003L8174
Needle plug, set (1 pcs.)		003Z0100
Ext. plug, set (1 pcs.)		003Z0106
Measuring needle, set (1 pcs.) 		003Z0107
Elbow test plug extension (1 pcs.)		003Z3944
Straight test plug extension (1 pcs.)		003Z3945
Straight plug extension set		003Z3946

Technical data

Nominal diameter	DN	40	50	65	80	100
Qnom factory setting ( $\Delta p_{pr}$ 25 kPa)	l/h	5000	6500	16800	19600	21000
Min. differential pressure ( $\Delta p_a$ ), Factory setting <sup>1)</sup>	kPa	42		60		
Setting range <sup>2)3)</sup>	Flow%	40-100				
	$\Delta p$ setting	0-20 turns		0-40 turns		
Nominal maximal pressure	bar	16 (PN16)				
Max. pressure drop		4				
Control valve characteristics	Linear					
Shut-off leakage rate	Acc. to ISO 5208 class A - no visible leakage					
CV stroke	mm	10	10	15	15	15
Connection	External thread (ISO 228/1) G2A			Flange (EN 1092-2)		
Connection actuator	Danfoss standard					
Flow medium	Water and water mixture for closed heating and cooling systems according to plant type I for DIN EN 14868. When used in plant Type II for DIN EN 14868 appropriate protective measures are taken. The requirements of VDI 2035, part 1 + 2 are observed.					
Medium temperature	°C	-10 ... 120				
<b>Materials in water</b>						
Body	Cast iron EN-GJL 250 (GG 25)					
Membrane and O-rings	EPDM					
Springs	W.Nr. 1.4568, W.Nr. 1.4310					
Cone (Pc)	CuZn40Pb3 -CW 614N, W.Nr. 1.4305					
Seat (Pc)/(Cv)	W.Nr. 1.4305					
Cone (Cv)	CuZn40Pb3 -CW 614N					
Screw	Stainless steel (A2)					
Flat gasket	NBR					
Sealing agent (for test plugs)	Dimenthcrylate Ester					

<sup>1)</sup> For other settings see table 6

<sup>2)</sup> Factory setting see fig. 13 and 14

<sup>3)</sup> Regardless of the setting, the valve can modulate below 1 % of set flow.

**Mounting**

AB-PM DN 40-100 should be mounted in the return pipe. The arrow on the valve body should correspond with the flow direction of the medium. The impulse tube should be connected to the supply pipe using the included 1/4"-1/16" adaptor (**003L8151**).

Alternatively, the impulse tube can be connected to a partner valve, such as ASV-BD or MSV-F2 <sup>1)</sup>. Using a partner valve offers additional service/troubleshooting functions such as flow verification, shut-off etc.

If the impulse tube is connected to the supply pipe the AB-PM functions as a differential pressure controller with flow limitation. The impulse tube can also be connected to the return pipe (upstream from the AB-PM) or to the red test plug with adapter **003Z0691**. In that case the AB-PM will function as a pressure independent control valve with 100% authority.

<sup>1)</sup> For information on partner valve see ASV and MSV-F2 datasheet

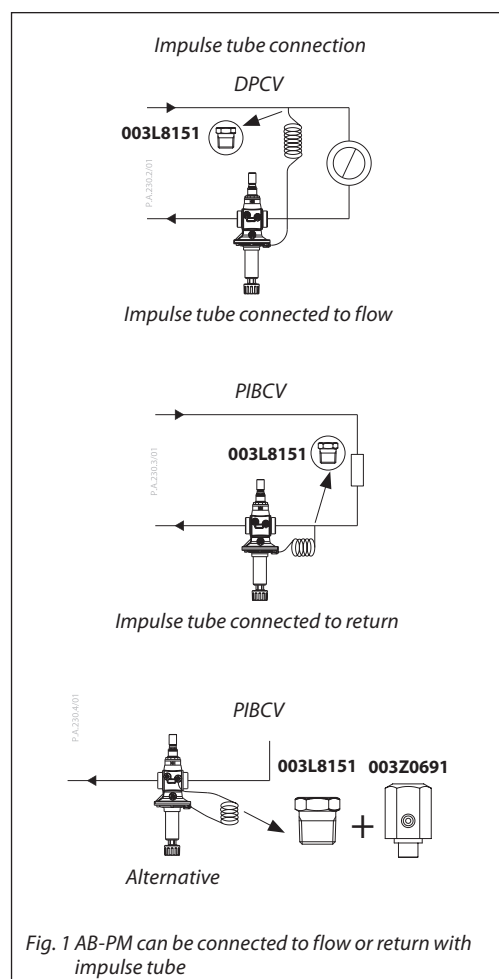

Fig. 1 AB-PM can be connected to flow or return with impulse tube

**Commissioning**

When filling the system make sure to open the supply valve before opening the return valve. The pressure on the upper side of the membrane (impulse tube) should always be higher than the pressure on the lower side of the membrane (at the valve)

Flush the impulse tube and ensure the HVAC system is de-aired before starting the system.

For the setting procedure please refer to the operating instructions enclosed with the product.

It is recommended that an FV filter be installed in the system supply pipe.

**Service and trouble shooting**

The valve can be manually shut off for service purposes, up to 16 Bar.

AB-PM is equipped with 3 test plugs for flow verification, service and trouble shooting.

Please check the following if the valve does not function correctly:

1. Is the flow direction through the valve correct?
2. Is the impulse tube fitted correctly and are any test plugs open?
3. Is the valve shut-off open? (see operating instructions)
4. Is the available pressure big enough?

**Application**  
-variable flow systems

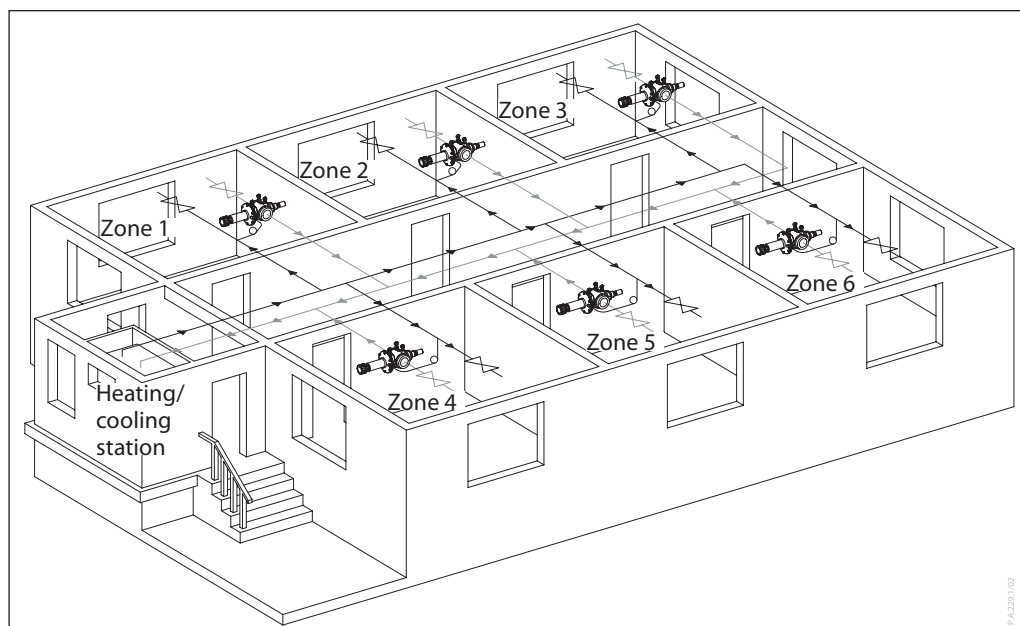

Fig. 2 Staged commissioning – 1st stage : ensuring  $\Delta p$  and flow for each zone

AB-PM DN 40 to 100 is the ideal solution for applications where a so called staged installation, hand over and commissioning is used. In such cases, the 1<sup>st</sup> stage is installation of backbone piping without terminal units. AB-PM is used as DPCV with flow limitation, ensuring the specified design pressure and flow to each zone. The 2<sup>nd</sup> stage is then the installation of terminal units.

Typical applications are shopping malls and shell & core office buildings.

The AB-PM ensures the required flow for each zone and maintains hydronic balance in the system.

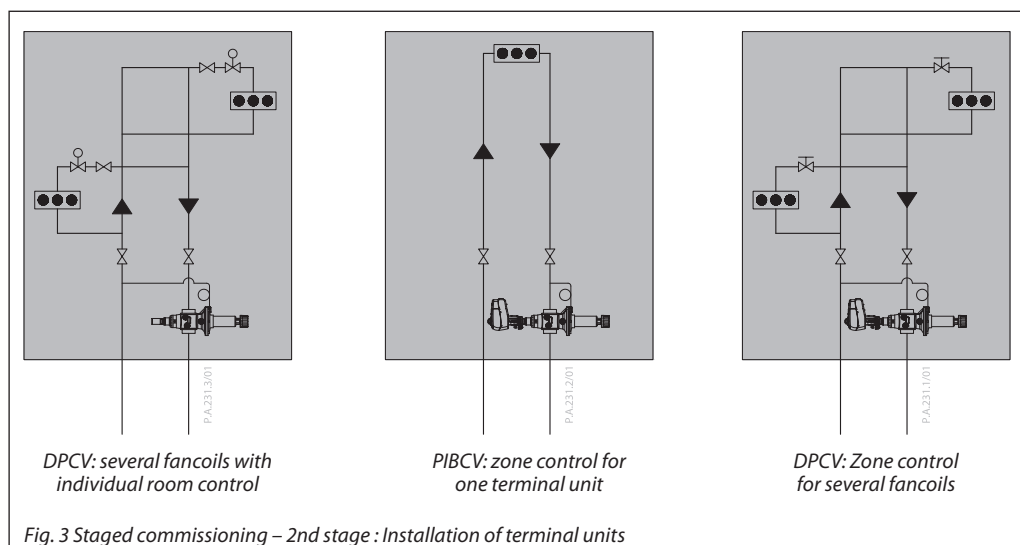

Fig. 3 Staged commissioning – 2nd stage : Installation of terminal units

In the 2<sup>nd</sup> stage of commissioning the installation of terminal units can be done. Optionally the AB-PM can be changed from differential pressure controller to pressure independent control valve. This allows flexibility when designing the zones. If only one terminal unit is used in the zone, the AB-PM as a PIBCV can be used to control that unit and no additional valves are needed.

**Flow verification /trouble shooting**

To verify that an installation functions per the design specifications the AB-PM (DN 40-100) has test plugs that allow measuring of the pressure difference  $\Delta p_r$ , or  $\Delta p_{cv}$  across the valve. In this way the pressure difference and flow can be verified for handover or troubleshooting.

At handover of the base building when the HVAC design conditions are specified but components are not yet installed in the zone, the differential pressure and flow for the valve and loop can only be verified by installing a bypass with the same dp as specified for the zone. For quick hand over, without flow verification, the calculated dp can be pre-set on the valve for the dp and flow demand of the loop.

In the 2<sup>nd</sup> stage of commissioning when the HVAC system has been installed in the zone, the differential pressure and flow can be verified for handover and troubleshooting.

The differential pressure can be measured using the following methods:

DPCV: Measure differential pressure from AB-PM to installed partner valve ( $\Delta p_r = p_0 - p_1$ ).

PIBCV: Measure the differential pressure across the control valve ( $\Delta p_{cv} = p_1 - p_2$ ).

To calculate the flow below formulas are used:

DPCV:

$$\Delta p_r = p_0 - p_1$$

$$Q = k v_{cv} \times \sqrt{\Delta p_r}$$

PIBCV:

$$\Delta p_{cv} = p_1 - p_2$$

$$Q = k v_{cv} \times \sqrt{\Delta p_{cv}}$$

For  $k v_{cv}$  values see datasheet "AB-QM flow checker DN 40-250"

For trouble shooting the available pressure can be verified, Closing the AB-PM valve fully and measuring  $p_0 - p_2$ .

Verifying the pressure and flow can be done by using Danfoss PFM or other dp measuring devices (select valve type: AB-QM)

**Differential pressure legend**

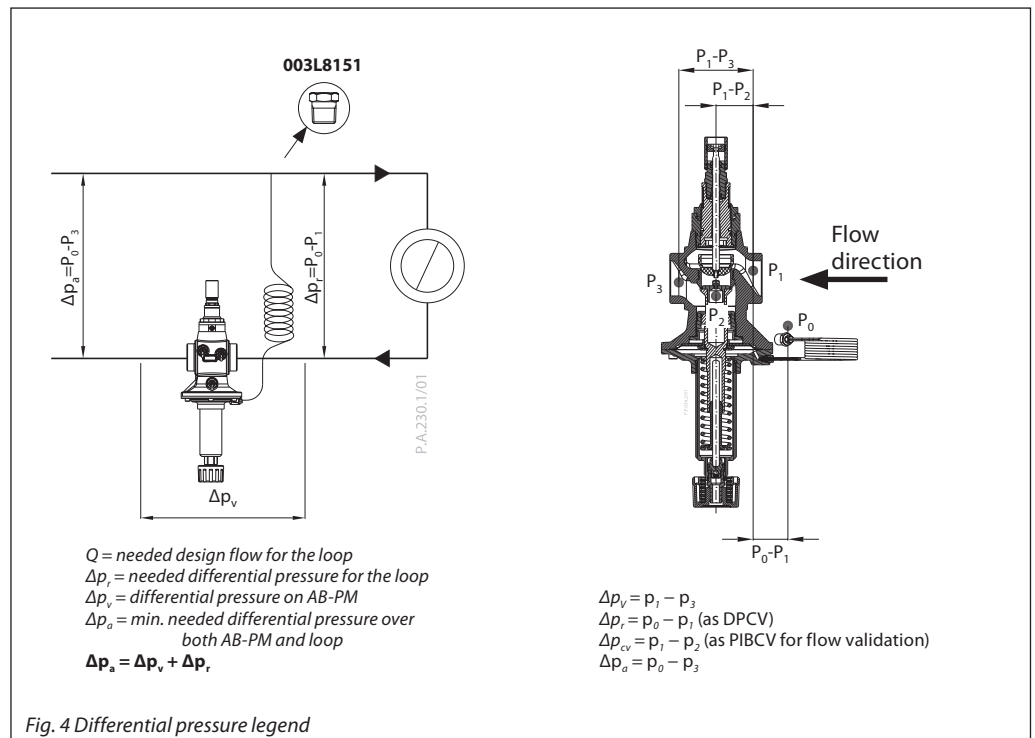

**Sizing**

AB-PM is to be sized based on the needed flow (Q) and the needed differential pressure drop for the zone ( $\Delta p_r$ ).

Max flow / $\Delta p_r$  for all sizes are presented in the sizing guide in fig. 5.

When pipe dimension has been selected, specific sizing, selection and setting can be identified based on Q and  $\Delta p_r$  in fig. 6-10.

Alternatively table 1-5 can be used for AB-PM sizing as well.

For needed flow and differential pressure outside specified in graphs and tables, setting can be calculated by linear distribution of setting.

For minimum needed available differential pressure ( $\Delta p_a$ ) at Q nominal see table 6.

Sizing graph -  $\Delta P$ / max. flow

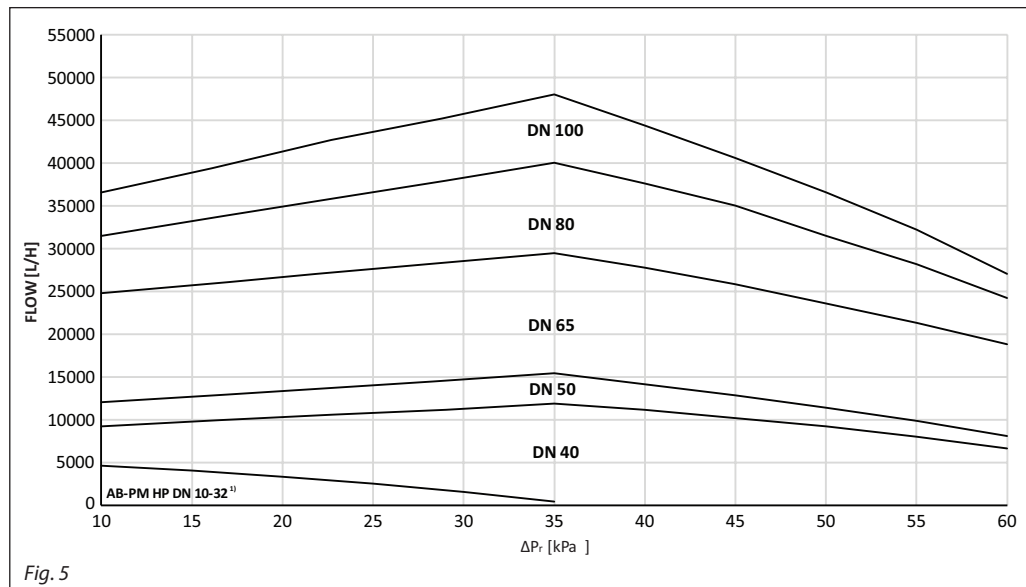

Fig. 5

1) See datasheet AB-PM DN 10-32

Sizing

Example 1

Given : Design flow to zone 4200 l/h, pressure drop over the zone at design flow 25 kPa.  
 Solution: AB-PM DN 40 is selected.  $\Delta p$  setting is kept at factory setting and flow limitation is changed to 80 %. AB-PM will control differential pressure of 25 kPa when design flow is achieved and the flow to the zone will be limited to 4200 l/h

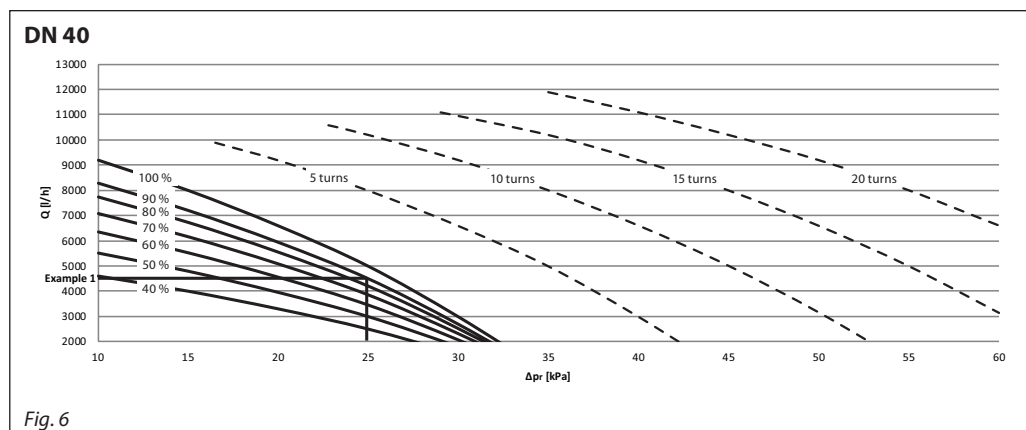
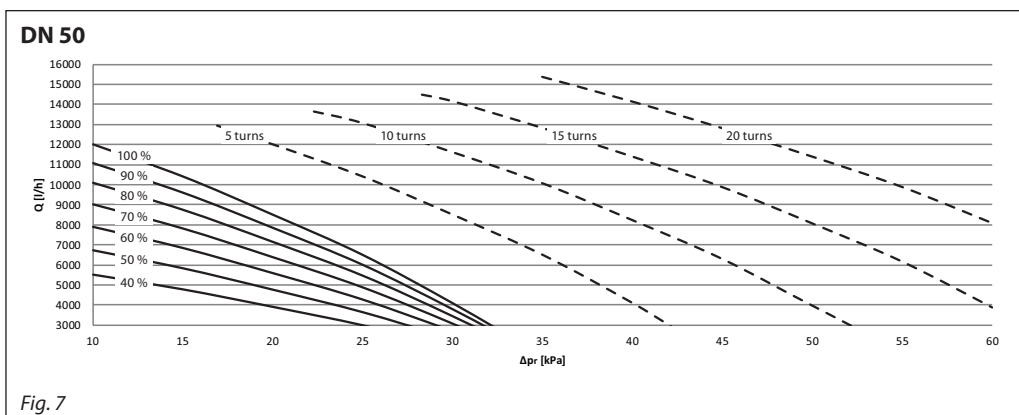

Fig. 6

DN 40 $\Delta p_r$ [kPa]	Flow limitation on $\Delta p$ factory setting						Factory setting 100% /0 turns	$\Delta p$ setting [kPa]			
	40%	50%	60%	70%	80%	90%		5 turns	10 turns	15 turns	20 turns
Q [l/h]											
10	4600	5520	6348	7084	7728	8280	9200				
15	4000	4800	5520	6160	6720	7200	8000				
20	3300	3960	4554	5082	5544	5940	6600	9200			
25	2500	3000	3450	3850	4200	4500	5000	8000	10200		
30			2070	2310	2520	2700	3000	6600	9200	11100	
35								5000	8000	10200	11900
40								3000	6600	9200	11100
45									5000	8000	10200
50									3150	6600	9200
55										5000	8000
60										3150	6600

Table 1

Sizing



DN 50	Flow limitation on $\Delta p_r$ factory setting						Factory setting 100% /0 turns	$\Delta p$ setting [kPa]			
	$\Delta p_r$ [kPa]	40%	50%	60%	70%	80%		90%	5 turns	10 turns	15 turns
Q [l/h]											
10	5520	6750	7920	9030	10080	11070	12000				
15	4784	5850	6864	7826	8736	9594	10400				
20	3910	4781	5610	6396	7140	7841	8500	12000			
25		3656	4290	4891	5460	5996	6500	10400	13095		
30				3085	3444	3782	4100	8500	11640	14155	
35								6500	10088	12825	15390
40								4100	8245	11400	14155
45									6305	9880	12825
50									3977	8075	11400
55										6175	9880
60										3895	8075

Table 2

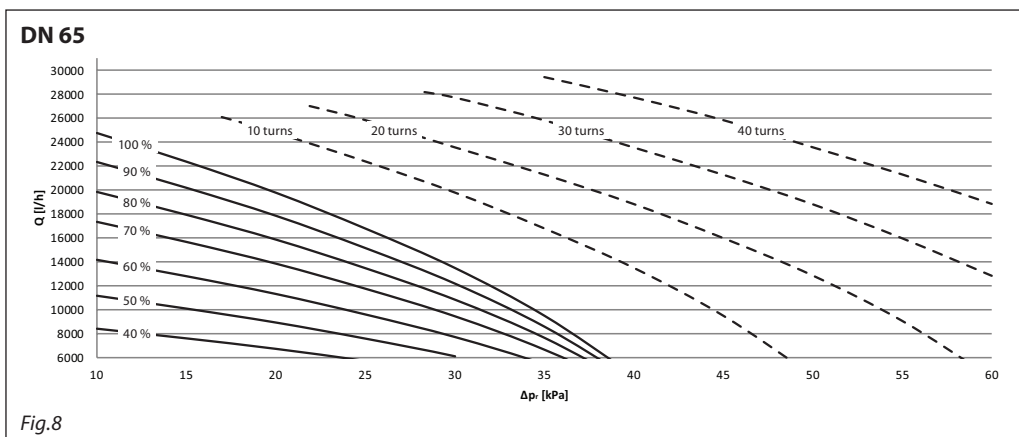

DN 65	Flow limitation on $\Delta p_r$ factory setting						Factory setting 100% /0 turns	$\Delta p$ setting [kPa]			
	$\Delta p_r$ [kPa]	40%	50%	60%	70%	80%		90%	10 turns	20 turns	30 turns
Q [l/h]											
10	8432	11160	14136	17360	19840	22320	24800				
15	7616	10080	12768	15680	17920	20160	22400				
20	6732	8910	11286	13860	15840	17820	19800	24800			
25		7560	9576	11760	13440	15120	16800	22400	25840		
30		6075	7695	9450	10800	12150	13500	19800	23560	27740	
35				6650	7600	8550	9500	16800	21280	25840	29450
40								13500	18810	23560	27740
45								9500	15960	21280	25840
50									12825	18810	23560
55									9025	15960	21280
60										12825	18810

Table 3

Sizing

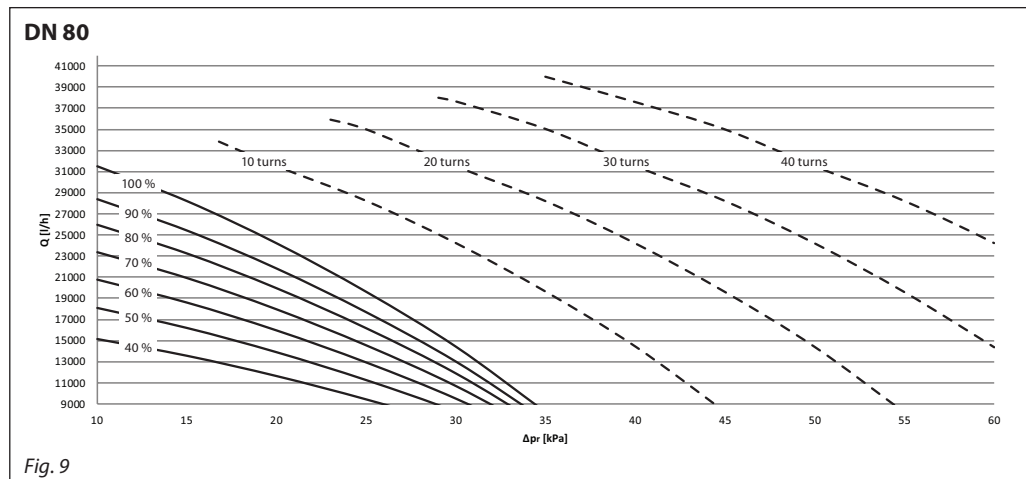

Fig. 9

DN 80 Δp <sub>r</sub> [kPa]	Flow limitation on Δp factory setting						Factory setting 100% /0 turns	Δp setting [kPa]			
	40%	50%	60%	70%	80%	90%		10 turns	20 turns	30 turns	40 turns
Q [l/h]											
10	15120	18113	20790	23373	25956	28350	<b>31500</b>				
15	13536	16215	18612	20924	23237	25380	<b>28200</b>				
20	11616	13915	15972	17956	19941	21780	<b>24200</b>	31500			
25	9408	11270	12936	14543	16150	17640	<b>19600</b>	28200	35000		
30			9504	10685	11866	12960	<b>14400</b>	24200	31500	37600	
35								19600	28200	35000	40000
40								14400	24200	31500	37600
45									19600	28200	35000
50									14400	24200	31500
55										19600	28200
60										14400	24200

Table 4

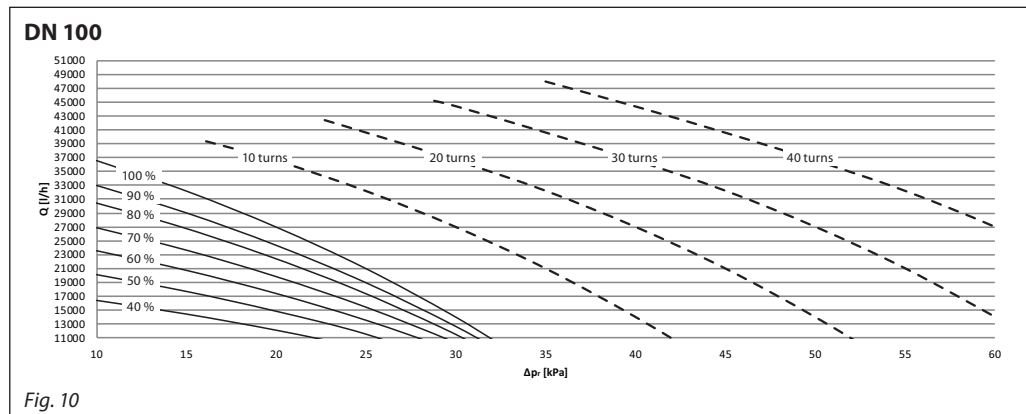

Fig. 10

DN 100 Δp <sub>r</sub> [kPa]	Flow limitation on Δp factory setting						Factory setting 100% /0 turns	Δp setting [kPa]			
	40%	50%	60%	70%	80%	90%		10 turns	20 turns	30 turns	40 turns
Q [l/h]											
10	16470	20130	23607	26901	30012	32940	<b>36600</b>				
15	14490	17710	20769	23667	26404	28980	<b>32200</b>				
20	12150	14850	17415	19845	22140	24300	<b>27000</b>	36600			
25			13545	15435	17220	18900	<b>21000</b>	32200	40600		
30					11480	12600	<b>14000</b>	27000	36600	44400	
35								21000	32200	40600	48000
40								14000	27000	36600	44400
45									21000	32200	40600
50									14000	27000	36600
55										21000	32200
60										14000	27000

Table 5



**Min. differential pressure ( $\Delta p_s$ )**

Nominal diameter	≤Factory setting	$\Delta p$ setting <sup>1)</sup>			
		≤100% /0 turns ( $\Delta p_s \geq 20$ kPa)	5 turns ( $\Delta p_s \geq 20$ kPa)	10 turns ( $\Delta p_s \geq 25$ kPa)	15 turns ( $\Delta p_s \geq 30$ kPa)
$\Delta p_s$ [kPa]					
DN40	42	52	63	74	85
DN50	42	52	63	74	85
DN65	60	72	83	94	105
DN80	60	72	83	94	105
DN100	60	72	83	94	105

Table 6

<sup>1)</sup> If application requires less dpr, for valve will be higher so flow validation across valve is needed in order to increase.

**Setting**

The AB-PM valves are factory preset to min.  $\Delta p$  setting with 100% flow.

For changing the setting please use the following procedure:

*Setting the desired differential pressure:*  
the setting on the AB-PM can be changed by turning the setting spindle to allow higher differential pressure. Turning the spindle clockwise increases the setting; turning it counter clockwise reduces the setting.

If the setting is not known, turn the spindle fully clockwise. With this the setting on AB-PM is at maximum value within setting range. Now turn the spindle backwards a number of times (n) as described in Fig. 13 or 14 until the required differential pressure setting is obtained.

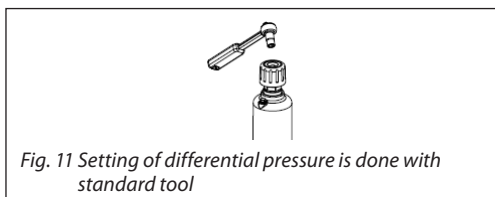

Fig. 11 Setting of differential pressure is done with standard tool

*Adjusting the flow limitation:*  
To give lower flow than factory setting the % scale on the AB-PM need to be adjusted according to sizing diagrams (figure 6 to 10).

The calculated flow can be adjusted easily with a standard tool. The presetting scale indicates values from 100 % flow to 40 %. Clock wise turning would decrease the flow value while counter clock wise would increase it.

Danfoss recommends a presetting/flow from 40 % to 100 %. Factory presetting is 100 %.

DN	Wrench
40-50	50
65-100	42

one turn is 10%  
Max. 25 Nm

Fig. 12 Setting of flow limitation with standard tool

**Design**

1. Shut off knob
2. Differential pressure setting spindle
3. Membrane
4. DP cone
5. Seat
6. Valve body
7. Control valve cone
8. Locking screw
9. Scale
10. Stuffing box
11. Spindle
12. Impulse tube
13. Brass handle

DN	40	50
	5	5

Factory presetting	DN 40-50
$\Delta p$ setting	min. setting (0 turns)
Flow %	100%

n (turns)	$\Delta p$ setting
0 turns	Min. setting (factory setting)
...	...
20 turns	Max. setting

Do not turn the spindle more than 20 turns as it will become disengaged.

Fig. 13 AB-PM DN 40-50

Design

1. Shut off knob
2. Differential pressure setting spindle
3. Membrane
4. DP cone
5. Seat
6. Valve body
7. Control valve cone
8. Locking screw
9. Scale
10. Stuffing box
11. Spindle
12. Impulse tube
13. Brass handle

n (turns)	$\Delta p$ setting
0	Min. setting (factory setting)
...	...
40	Max. setting

Factory presetting	DN 65-100
$\Delta p$ setting	min. setting (0 turns)
Flow %	100%

DN	65	80	100	DN	65	80	100
	42				13 23		

Do not turn the spindle more than 40 turns as it will become disengaged.

Fig. 14 AB-PM DN 65-100

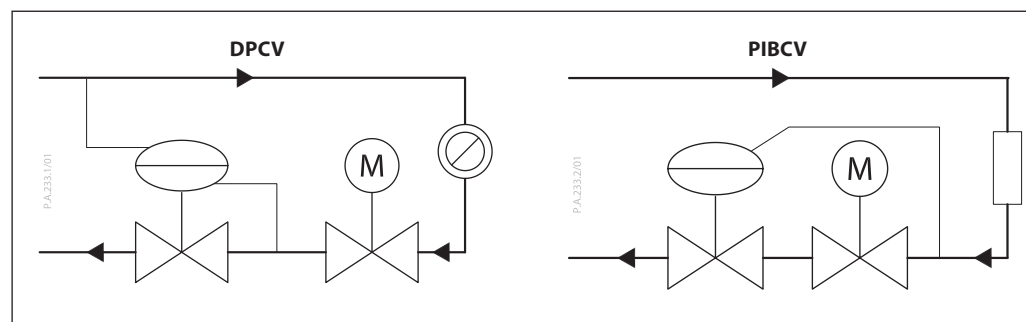

AB-PM is a combined automatic balancing valve. It works as differential pressure controller (DPCV) or pressure independent control valve (PIBCV), flow limiter and zone controller/control valve. As DPCV it keeps a constant differential pressure over the control loop and when installed as a PIBCV it keeps the pressure constant over the control valve ensuring it full authority.

Higher pressure acts on the lower side of the control membrane (3) via an impulse tube (12) while the lower pressure in the return pipe acts on the upper side of the membrane (use either membrane or diaphragm. Do not mix these two, it will help clarity). When available pressure increases at partial loads, the membrane closes and thus keeps the differential pressure stable.

The control part of AB-PM is working as a flow limiter. This enables to set a required combination of the design flow as well as the needed  $\Delta p$ . By presetting the AB-PM, the flow rate is defined based on the pressure demand of the loop or terminal unit.

With an actuator mounted on the valve, AB-PM can be used as a zone valve. When the AB-PM is converted to a PICV it can be used, together with an actuator, as a full authority control valve with either a linear or a logarithmic characteristic.

Dimensions

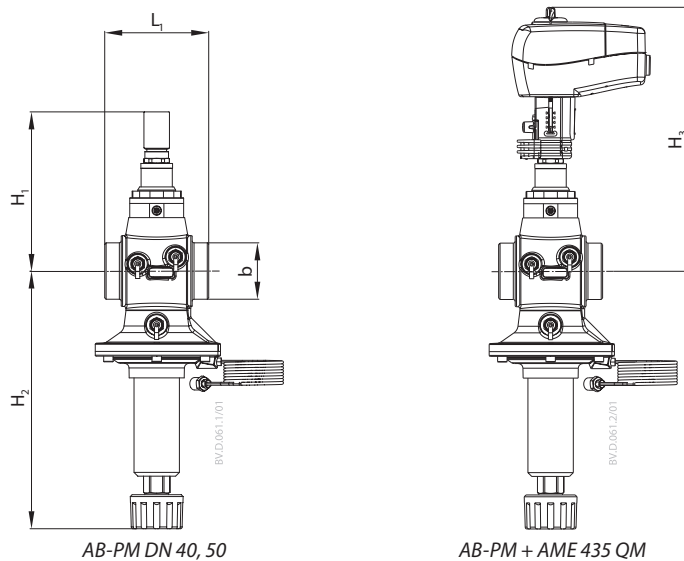

Type	L <sub>1</sub>	H <sub>1</sub>	H <sub>2</sub>	H <sub>3</sub>	b	Weight (kg)
	mm					
DN40	110	168	273	280	G 2 (ISO228/1)	6.9
DN50	130				G 2 ½ (ISO228/1)	7.8

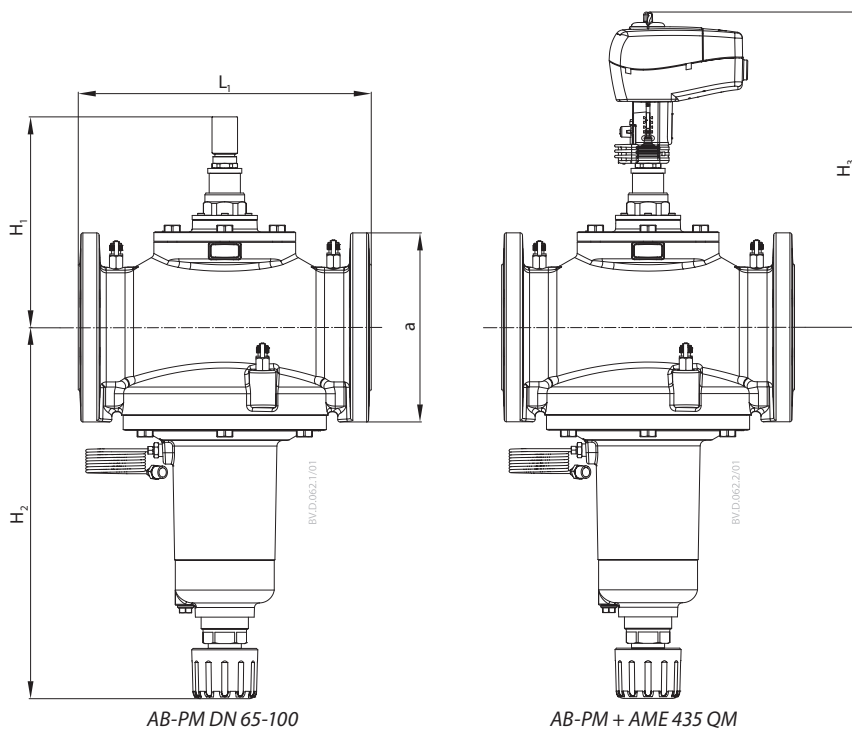

Type	L <sub>1</sub>	H <sub>1</sub>	H <sub>2</sub>	H <sub>3</sub>	a (EN 1092-2)	Weight (kg)
	mm					
DN 65	290	218	388	330	185	41
DN 80	310	223	393	335	200	46
DN 100	350	239	451	350	220	64

## Tender text

AB-PM DN 40-100 is a combined differential pressure controller for dynamic hydronic balance.

- The valve should be able to ensure hydronic balance for each zone with one or more terminal units.
- Valve shall have flexible functionality as either DPCV or PIBCV.
- The valve can be connected to either flow or return pipe via impulse tube
- With impulse tube connected to flow, the valve should keep differential pressure across the branch by membrane driven controller.
- With impulse tube connected to the return, the valve should control the flow on every terminal unit
- Valve should have shut-off function.
- Valve should have possibility to mount actuator without effecting presetting.
- Valve should have variable setting. Setting value should allow to set a combination of needed differential pressure and flow for zone.
- Setting should be lockable to prevent unauthorized change.
- Control valve should have metal to metal sealing to ensure sufficient performance of differential pressure control at low flows.
- Shut-off service function should be possible to do with hand or a tool. The Dp controller should have soft sealing to ensure sufficient closing in case of zero flow
- Valve should be delivered with min. 2.5 m impulse tube. Diameter of impulse tube should not be bigger than 1.2 mm.
- Valve should be delivered in reliable packaging for safe transport and handling.

Product characteristics:

- a) Pressure class: PN16
- b) Max. pressure drop across AB-PM: 4 bar
- c) Temperature range: -10 ... 120 °C
- d) Connections size: DN 40-100
- e) Connection type: External tread ISO 228/1 (DN 40, DN50 ), Flange EN1092-2 (DN 65-100)
- f) Installation: in return pipe with connection via impulse tube to flow or return pipe
- g) Setting range: Flow: 40-100%,  $\Delta p$  setting : 0-20 turns (DN40, DN50), 0-40 turns (DN65-DN100)
- h) Nom. flow at factory setting ( $\Delta p$  25 kPa): 5000l/h (DN40), 6500 l/h (DN50), 16800 l/h (DN65), 19600 (DN80), 21000 (DN100)
- i) Minimum differential pressure across valve and zone at factory setting 45 kPa (DN40, DN50), 60 kPa (DN65-100)