

Data sheet

Shut-off ball valve for high pressure

Type GBCH for R744 / CO₂ (90 bar / 1305 psi) Version 2

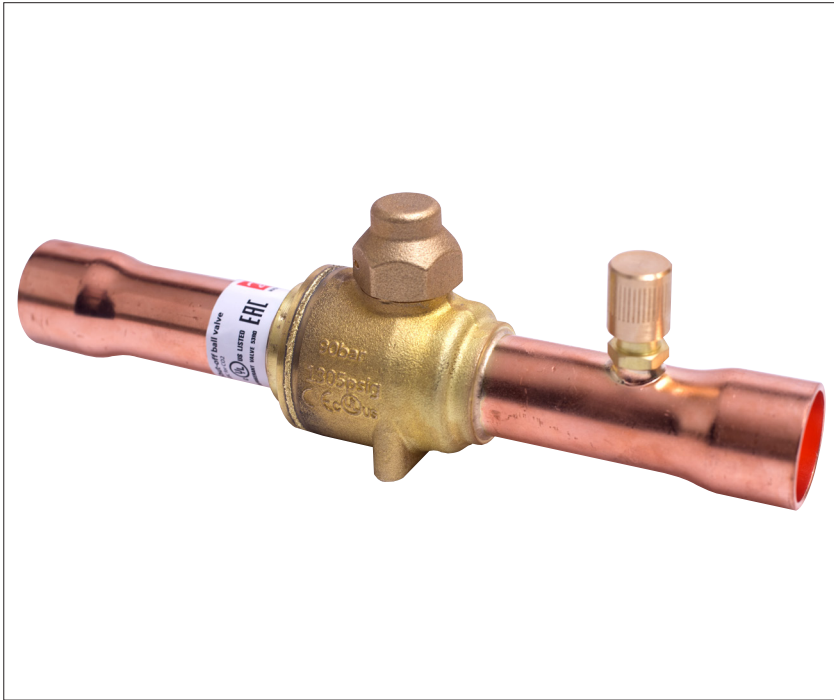

Danfoss shut-off ball valves, type GBCH for R744 (CO₂) high pressure are manually operated shut-off valves for CO₂ systems.

The valves are specifically designed for intrinsic standstill security, meaning that the valves can withstand pressures normally arising when the refrigeration system is shut off, i.e. during serving or during unexpected power failure.

The valve structure and materials are designed and tested specifically for use with CO₂ refrigerant. The valves are approved for use in all parts of the system with pressure ratings lower than the below stated Maximum Working Pressure, typically the liquid, suction, gas-bypass lines.

Features

- ¼ turn from fully open to fully closed
- GBCH for R744 is designed for:
GBCH 6s - 28s : 90 bar / 1305 psig
GBCH 35s - 42s: 75 bar / 1085 psig
max. working pressure
- Rotation stops at fully open and fully closed positions
- Indicator on spindle top shows if the valve is open or closed.
- Double O-ring stem seal design
- Precision laser welded construction
- Burst-proof spindle design
- Valve seal of low friction, tight-sealing modified PTFE Teflon®
- Drilled and tapped for panel mounting
- Relief hole design to release entrapped liquid
- Selected O-ring material for CO₂ refrigerant
- Advanced design ensures trusted bi-flow function.
- Customized brass material ensures consistent performance under aggressive environment

Approvals

Technical data

Refrigerants	R 744 (CO ₂)
Oils:	POE, PAG
Media temperature range	-40 °C – 100 °C / -40 °F – 212 °F
Max. working pressure (PS / MWP)	GBCH 6s - 28s: → 90 bar / 1305 psig
	GBCH 35s - 42s: → 75 bar / 1085 psig
Flow direction	bi-flow

Notes: For the application use with R744 as part of a secondary loop or cascade:

1. The design pressure of the refrigerant containing component is not less than the design pressure of the associated components.
2. The component is not provided with any pressure relief or pressure regulating relief valve and that a sufficient number of valves having capacity deemed adequate shall be field-installed on the refrigeration system.
3. When the refrigeration system is de-energized, venting of R744 may occur through the pressure regulating relief valves, and may need to be recharged, but the valve should not be defeated or bypassed.
4. A sufficient number of pressure relief and pressure regulating valves may need to be provided based upon system capacity and located such that no stop valve is provided between the relief valve and the parts or section of the system being protected.

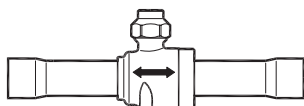
Ordering

GBCH without access port, solder ODF/ODF, copper connections

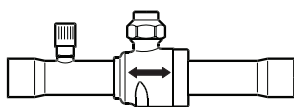
Type	Solder ODF / ODF connection		K _v value ¹⁾	C _v value ¹⁾	Max. working pressure (PS/MWP)		Code no.
	[inch]	[mm]			[bar]	[psig]	
GBCH 6s	1/4	–	1.78	2.06	90	1305	009L7415
	–	6	1.78	2.06	90	1305	009L7395
GBCH 10s	3/8	–	6.31	7.29	90	1305	009L7416
	–	10	6.31	7.29	90	1305	009L7396
GBCH 12s	1/2	–	12.87	14.88	90	1305	009L7417
	–	12	12.87	14.88	90	1305	009L7397
GBCH 16s	5/8	16	11.77	13.61	90	1305	009L7418
GBCH 18s	3/4	–	31.07	35.92	90	1305	009L7419
	–	18	31.07	35.92	90	1305	009L7399
GBCH 22s	7/8	22	24.47	28.29	90	1305	009L7420

¹⁾ calculated based on fluid dynamic equations

GBCH with access port, solder ODF/ODF, copper connections

Type	Solder ODF / ODF connection		K _v value ¹⁾	C _v value ¹⁾	Max. working pressure (PS/MWP)		Code no.
	[inch]	[mm]			[bar]	[psig]	
GBCH 6s	1/4	–	1.78	2.06	90	1305	009L7581
	–	6	1.78	2.06	90	1305	009L7580
GBCH 10s	3/8	–	6.31	7.29	90	1305	009L7582
	–	10	6.31	7.29	90	1305	009L7583
GBCH 12s	1/2	–	12.87	14.88	90	1305	009L7585
	–	12	12.87	14.88	90	1305	009L7584
GBCH 16s	5/8	16	11.77	13.61	90	1305	009L7586
GBCH 18s	3/4	–	31.07	35.92	90	1305	009L7588
	–	18	31.07	35.92	90	1305	009L7587
GBCH 22s	7/8	22	24.47	28.29	90	1305	009L7589

¹⁾ calculated based on fluid dynamic equations

GBCH without access port, butt weld, stainless steel connections

Type	Butt weld connection		K _v value ¹⁾	C _v value ¹⁾	Max. working pressure (PS/MWP)		Code no.
	[inch]	[mm]			[bar]	[psig]	
GBCH 28s	–	28	96.72	111.81	90	1305	009L7406
GBCH 35s	–	35	106.95	123.63	75	1085	009L7410
GBCH 42s	–	42	150.98	174.53	75	1085	009L7411

¹⁾ calculated based on fluid dynamic equations

Data sheet | Shut-off ball valve for high pressure, type GBCH for R744 (CO₂) Version 2

Spare parts

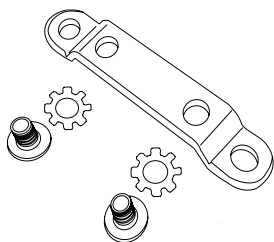

Bracket kit

Type	Valve connection size		Industrial pack [pcs.]	Code no.
	[inch]	[mm]		
GBC 6s - 16s	1/4 - 5/8	6 - 16	12	009G7084
GBC 18s - 22s	3/4 - 7/8	18 - 22	12	009G7085
GBC 28s	1 1/8	28	10	009G7086
GBC 35s	1 3/8	35	5	009G7087
GBC 42s	1 5/8	42	4	009G7088



Seal cap kit

Type	Valve connection size		Industrial pack [pcs.]	Code no.
	[inch]	[mm]		
GBC 6s - 22s	1/4 - 7/8	6 - 22	6	009L7210
GBC 28s - 35s	1 1/8 - 1 3/8	28 - 35	4	009L7211
GBC 42s	1 5/8	42	4	009L7212

Design / Function

1. Connection
2. Valve body
3. Ball seat (modified PTFE)
4. Valve tail
5. Stainless steel ball
6. Double O-ring seal in spindle
7. Cap seal (PTFE)
8. Seal cap
9. Spindle
10. Pin
11. Guide ring
12. Schrader valve
13. Relief hole

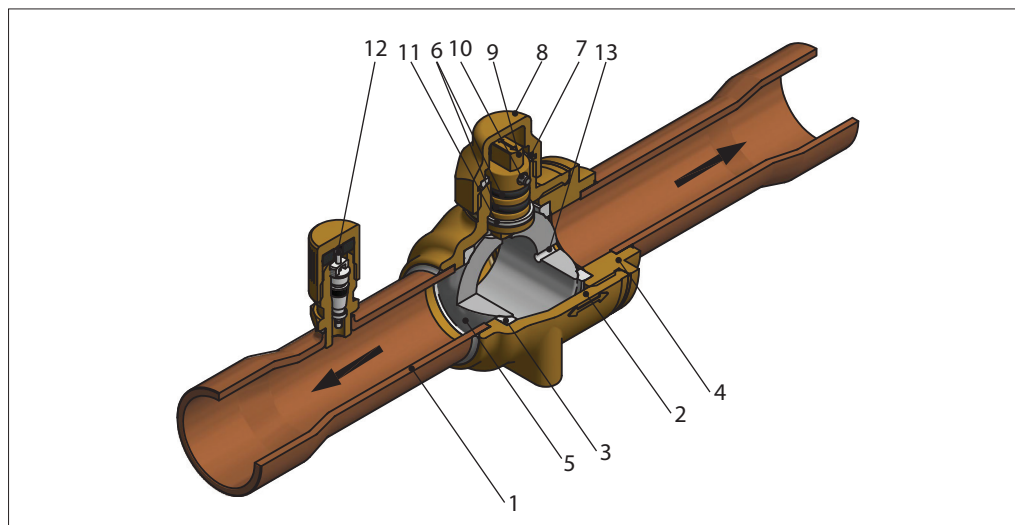

Direct flow gives maximum through-flow with minimum pressure drop across valve. The combination of laser-welded valve body (2) and valve tail (4), ball seat/seal (3), double O-ring seal in spindle (6), and cap seal (7) provides the best tightness.

Dimensions and weights

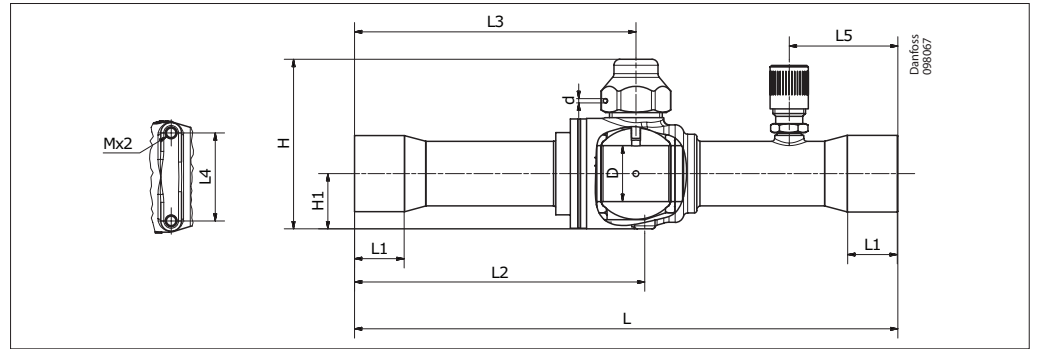

SI units

Type	Connection		Access port	H	H1	L	L1	L2	L3	L4	L5	M	D	d	Weight
	[inch]	[mm]		[mm]	[mm]	[mm]	[mm]	[mm]	[mm]	[mm]	[mm]	[mm]	[mm]	[mm]	[mm]
GBCH 6s	1/4	6	No/Yes	50	15	139	5	75	73	22	31	M4 × 0.7	14	1.5	0.2
GBCH 10s	3/8	10	No/Yes	50	15	139	7	75	73	22	31	M4 × 0.7	14	1.5	0.2
GBCH 12s	1/2	12	No/Yes	50	15	161	8	86	84	22	31	M4 × 0.7	14	1.5	0.2
GBCH 16s	5/8	16	No/Yes	50	15	161	10	86	84	22	31	M4 × 0.7	14	1.5	0.2
GBCH 18s	3/4	18	No/Yes	58	19	185	12	99	96	30	37	M4 × 0.7	19	1.5	0.4
GBCH 22s	7/8	22	No/Yes	58	19	185	15	99	96	30	37	M4 × 0.7	19	1.5	0.4

US units

Type	Connection		Access port	H	H1	L	L1	L2	L3	L4	L5	M	D	d	Weight
	[inch]	[mm]		[inch]	[inch]	[inch]	[inch]	[inch]	[inch]	[inch]	[inch]	[mm]	[inch]	[inch]	[lbs]
GBCH 6s	1/4	6	No/Yes	2.0	0.6	5.5	0.2	3.0	2.9	0.9	1.2	M4 × 0.7	0.6	0.1	0.5
GBCH 10s	3/8	10	No/Yes	2.0	0.6	5.5	0.3	3.0	2.9	0.9	1.2	M4 × 0.7	0.6	0.1	0.5
GBCH 12s	1/2	12	No/Yes	2.0	0.6	6.3	0.3	3.4	3.3	0.9	1.2	M4 × 0.7	0.6	0.1	0.5
GBCH 16s	5/8	16	No/Yes	2.0	0.6	6.3	0.4	3.4	3.3	0.9	1.2	M4 × 0.7	0.6	0.1	0.5
GBCH 18s	3/4	18	No/Yes	2.3	0.7	7.3	0.5	3.9	3.8	1.2	1.5	M4 × 0.7	0.7	0.1	1.0
GBCH 22s	7/8	22	No/Yes	2.3	0.7	7.3	0.6	3.9	3.8	1.2	1.5	M4 × 0.7	0.7	0.1	1.0

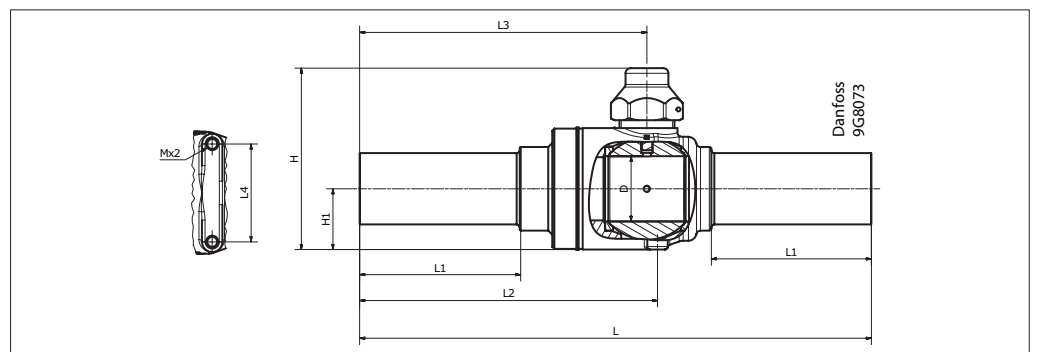

SI units

Type	Connection	H	H1	L	L1	L2	L3	L4	L5	M	D	d	Weight
	[mm]	[mm]	[mm]	[mm]	[mm]	[mm]	[mm]	[mm]	[mm]	[mm]	[mm]	[mm]	[Kg]
GBCH 28s	28	80	25	208	65	115	116	38		M4 × 0.7	25.5	1.5	0.9
GBCH 35s	35	89	30	251	79	146	141	48		M6 × 1.0	32	1.5	1.5
GBCH 42s	42	110	35	281	88	162	156	55		M6 × 1.0	38	1.5	2.5

US units

Type	Connection	H	H1	L	L1	L2	L3	L4	L5	M	D	d	Weight
	[mm]	[inch]	[inch]	[inch]	[inch]	[inch]	[inch]	[inch]	[inch]	[mm]	[inch]	[inch]	[lbs]
GBCH 28s	28	3.1	1.0	8.2	2.6	4.5	4.6	1.5		M4 × 0.7	1.0	0.1	1.9
GBCH 35s	35	3.5	1.2	9.9	3.1	5.7	5.6	1.9		M6 × 1.0	1.3	0.1	3.3
GBCH 42s	42	4.3	1.4	11.1	3.5	6.4	6.1	2.2		M6 × 1.0	1.5	0.1	5.4

Danfoss can accept no responsibility for possible errors in catalogues, brochures and other printed material. Danfoss reserves the right to alter its products without notice. This also applies to products already on order provided that such alterations can be made without consequential changes being necessary in specifications already agreed. All trademarks in this material are property of the respective companies. Danfoss and the Danfoss logotype are trademarks of Danfoss A/S. All rights reserved.