

Data Sheet

Gas detection unit
Premium

Type **GD Premium, Premium+, Premium Duplex, Premium Remote, Premium Flex and Premium Uptime**
Next generation gas detection for industrial refrigeration



The Premium line gas detection units are used for monitoring and warning of hazardous gas concentrations. They can be used for detecting most commonly used refrigerants. Depending on the application and model, each unit is available with one or two of 4 sensor types.

The Premium line gas detection units are intended as Stand-alone, or connected to a central system like Gas Detection Controller Unit, or a PLC.

As stand-alone the on-board relays can be used for activation of alarm devices, while the Analog or RS485 Modbus connection to a central system allows additional centralized monitoring and alarm activation.

4 out of the 6 Premium models have integrated Display/keypad for direct access to the user interface

The gas detection units come with a factory default, 2-step alarm set-up ready for use. The user interface enables the user to configure two individual alarm settings. Alarm 1, a pre-alarm indicating the gas level has passed a predefined threshold 1, and - if the gas level passes predefined threshold 2 - the final alarm 2.

Features

- Digital, factory configured and pre-calibrated gas detectors for plug-and-play installation (no adjustment required)
- Easy configuration via Display/keypad (some models) and intuitive user-interface; helps simplify operator handling and minimize risk of operational, settings and calibration errors
- Stand-alone (integrated relays) and/or flexible connection to central controller - by either Analog or RS485 open Modbus communications
- Wide selection of refrigerants, sensor types and detection ranges
- 2 Sensor versions available (different sensor types)
- Remote sensor location possible
- Fieldbus wiring - connect and power up to 96 sensors, wire length max. 900 meters (2953 ft) per segment; expansion modules permits additional segments
- Automatic self-diagnostics to ensure correct communication and operation
- Sensor seal cap to prevent premature exposure during installation
- Digital user interface ensures higher sensor accuracy
- Reduced risk of false alarms due to temperature compensated sensors
- Password protected alarm settings allowing authorized access only
- LED status signals and alarms
- Buzzer & Light option for local audio and visual alarms (Premium+, Premium Uptime)
- On-board acknowledge button to reset alarms and to verify that no gas leaks are present
- Service alerts on unit, controller or both, readable via service tool Display
- Quick and precise calibration procedures - either by Plug & Play replacement sensors or calibration with gas. No potentiometers or multi-meters required
- For improved safety and to optimize the lifetime of the sensor, degenerated sensors with too low sensitivity (<30%) are rejected during calibration process
- Conformity to EN 50271, EN 61010-1, ANSI/UL 61010 1, CAN/CSA-C22.2 No. 61010-1
- Enables regulatory compliance with EN 378:2016, ISO 5149:2014, IIR 2-2017, and ASHRAE 15:2016

Functions

Working principle/Operation

One (or two) sensor(s) are connected to the Premium sensor board via local bus (when two sensors connected, they must be of a different type). The Sensor board provides the power supply of the sensor(s) and prepares the measured data for digital communication.

The operation menu of the Premium software is accessed through the Display (if fitted), or the connected Gas Detection Controller, or via the dedicated GD Service tool (or PC tool). The Service tool (or PC tool) is plugged directly to the board of the unit. These interfaces with Display allow the unit configuration, setting of the unit alarm levels and calibration of the attached sensor(s).

The service tool (or PC tool) can be used on all units across the Basic, Premium and Heavy Duty platforms.

For Stand-alone units the alarm signals are handled by the unit software, which activates the integrated relays directly. For central controlled units the alarm signals are handled by the Gas Detection Controller (or a PLC) via the 4-20 mA (2-10V) analog output or the RS485 open Modbus communication.

For additional operational safety the changing of parameters is password protected allowing authorized access only. The factory default password can easily be customized.

Table 1: Digital outputs with 3 relays

Action	Reaction	Reaction	Reaction	Reaction	Reaction	Reaction
	Relay 1 (Alarm1)	Relay 2 (Alarm2)	Flashlight X13-7	Horn X13-6	Relay 3 (Fault)	LED
Gas signal < alarm threshold 1	OFF	OFF	OFF	OFF	ON	GREEN
Gas signal > alarm threshold 1	ON	OFF	OFF	OFF	ON	RED Slow blinking
Gas signal > alarm threshold 2	ON	ON	ON	ON	ON	RED Fast blinking
Gas signal ≥ alarm threshold 2, but ackn. button pressed	ON	ON	ON	OFF after delay ON		RED Fast blinking
Gas signal < (alarm threshold 2 - hysteresis) but ≥ alarm threshold 1	ON	OFF	OFF	OFF	ON	RED Slow blinking
Gas signal < (alarm threshold 1 - hysteresis) but not acknowledged	OFF	OFF	OFF	OFF	ON	RED Very fast blinking
No alarm, no fault	OFF	OFF	OFF	OFF	ON	GREEN
No fault, but maintenance due	OFF	OFF	OFF	OFF	ON	GREEN Slow blinking
Communication error	OFF	OFF	OFF	OFF	OFF	YELLOW

Product specification

Design

General info

- Cable gland not mounted but enclosed
- 4 mounting ears included
- Sensor head mounted bottom right (not Premium Remote)
- Alarm device (buzzer & 3 light alarm) mounted bottom left (only Premium +, Premium Uptime)

Figure 1: GD Premium, Premium+, Premium Duplex, Premium Remote, Premium Flex and Premium Uptime

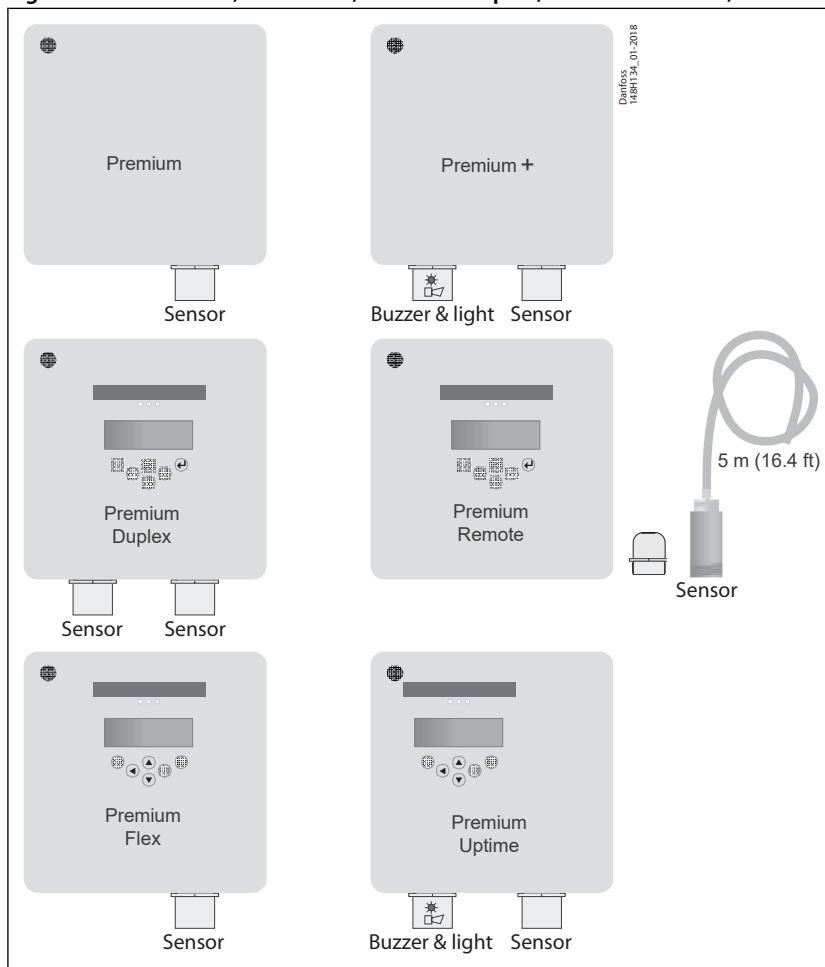

Gas types and thresholds

Table 2: Gas types and thresholds

Sensor	Sensor Type	Range	Alarm1	Alarm2	Hysteresis
Ammonia EC 100	Electrochemical	0 – 100 ppm	25 ppm	35 ppm	2 ppm
Ammonia EC 300	Electrochemical	0 – 300 ppm	25 ppm	150 ppm	2 ppm
Ammonia EC 1000	Electrochemical	0 – 1000 ppm	500 ppm	900 ppm	25 ppm
Ammonia EC 5000	Electrochemical	0 – 5000 ppm	1000 ppm	4500 ppm	50 ppm
Ammonia SC 1000	Semiconductor	0 – 1000 ppm	500 ppm	900 ppm	25 ppm
Ammonia SC 10000	Semiconductor	0 – 10000 ppm	5000 ppm	9000 ppm	250 ppm
Ammonia P LEL	Pellistor	0 – 100% LEL (0 – 140000 ppm)	21% LEL (30000 ppm)	21% LEL (30000 ppm)	1 % LEL
CO ₂ IR 20000 (2% Vol)	Infrared	0 – 2% Vol (0 – 20000 ppm)	0.5 % Vol (5000 ppm)	0.9% Vol (9000 ppm)	0.025% Vol
CO ₂ IR 50000 (5% Vol)	Infrared	0 – 5% Vol (0 – 50000 ppm)	1% Vol (10000 ppm)	1.8% Vol (18000 ppm)	.05% Vol

Gas detection unit, Premium

Sensor	Sensor Type	Range	Alarm1	Alarm2	Hysteresis
HCFC R123 SC 2000	Semiconductor	0 – 2000 ppm	500 ppm	900 ppm	25 ppm
HCFC R401 SC 2000	Semiconductor	0 – 2000 ppm	500 ppm	900 ppm	25 ppm
HFC R404A, R507 SC 2000	Semiconductor	0 – 2000 ppm	500 ppm	900 ppm	25 ppm
HFC R134A SC 2000	Semiconductor	0 – 2000 ppm	500 ppm	900 ppm	25 ppm
HC R290/Propane P 5000	Pellistor	0 – 5000 ppm	800 ppm	2500 ppm	40 ppm

i NOTE:

Hysteresis = 5% of Alarm1 (rounded up to the next higher integer).

Alarm thresholds can have the same value, therefore the relays and/or the buzzer and LED can be triggered together.

LEL/LFL=Lower explosive limit / Lower flammability limit.

"It is not recommended to set alarm levels below 10% or above 90% of the measuring range."

Electrical

Table 3: Electrical

Details	Description
Power supply	24 V DC \pm 20 %, reverse-polarity protected
Power consumption (24 V DC)	Max. 210 mA (5.1 VA)
Alarm relays (3)	250 V AC, 5 A, potential-free, contacts (SPDT)
Transistor output (2) (connector X13)	24 V DC / 0.1 A (switching to plus) (only at 24 V DC power supply)
	Proportional, overload and short-circuit proof, load \leq 500 Ohm
Analog output signal (1)	4 – 20 mA = measuring range 3.0 < 4 mA = underrange > 20 - 21.2 mA = overrange 2.0 mA = fault (configurable)
Output for local bus	5 V DC, 250 mA max. Overload, short-circuit and reverse-polarity protected

Ambient conditions

Table 4: Ambient conditions

Details	Description
Temperature range	Model dependant. See ordering section.
Humidity range	15 – 95 % RH not-condensing
Storage temperature	+5 °C to +30 °C (+41 °F to +86 °F)
Storage time	12 months

Serial interface

Table 5: Serial interface

Details	Description
Local bus	1-wire / 19200 Baud
Fieldbus	RS 485 / 19200 Baud
Tool bus	2-wire / 19200 Baud

Physical

Table 6: Physical

Details	Description	
Housing	Type C	Type E (Premium Uptime)
Material	Polycarbonate	
Combustion	UL 94 V2	
Housing colour	Black	
Dimensions (W x H x D in mm)	130 x 130 x 75	130 x 130 x 99
Weight (kg)	Approx. 0.6 kg	Approx. 0.7 kg
Protection class	IP65	
Installation	Wall mounting	

Gas detection unit, Premium

Details	Description
Cable entry	Standard 6 x M20/25
Wire connection:	
Local bus (SC2)	3-pin connector
Digital input, analog output	Screw-type terminal min. 0.25 mm ² , max. 1.3 mm ² (min. 25 AWG, max. 17 AWG)
Power supply, relays	Screw-type terminal min. 0.25 mm ² , max. 2.5 mm ² (min. 25 AWG, max. 14 AWG)
Cable lengths local bus for Remote Sensor Board	Max. 5 m (16.4 ft.)

Display (not Premium and Premium+)

Table 7: Display (not Premium and Premium+)

Details	Description
Temperature range	-20 °C to +50 °C (-4 °F to 122 °F)
LCD	Two lines, 16 characters each, background highlighted in two colours
Operation	Menu driven via six push-buttons
Power consumption	5 V, 60 mA, 0.3 VA

Status LED

Table 8: Status LED

Details	Description
Colour / Mode	Red / yellow / green (alarm – fault – operation - service)
Protection class	IP65

Warning buzzer

Table 9: Warning buzzer

Details	Description
Acoustic pressure	> 85 dB (A) (0.1 m distance)
Frequency	2300 Hz
Protection class	IP65

UPS (only Premium Uptime)

Table 10: UPS (only Premium Uptime)

Details	Description
Power unit with wide range input	90 – 240 V AC - 50/60 Hz
Output rating	15 VA
Rechargeable battery	12 V, 0.8 Ah
Operating time	> 60 min

Service & maintenance

The Premium line gas detection units are calibrated either by replacing of sensor heads or by calibration with gas.

Plug & Play replacement sensors are pre-calibrated and factory certified for quick and easy calibration procedure. The sensor is connected to the local bus via a plug connection enabling easy and simple exchange of sensor instead of a calibration. The internal X-change routine recognizes the exchanged sensor during the exchange process and restarts the measurement mode automatically. An LED indicates the correct procedure of the exchange operation. To ensure the proper functioning of the units and to prevent human errors, the sensor head can only be replaced by the same type and ppm range (exact replacement) that match the configuration. If a different sensor head is installed, the GD unit will show a communication error.

As an alternative, calibration with gas can be performed via the service tool (or PC tool), calibration gas with correct concentration and the Danfoss calibration adapter. The Danfoss gas detection units have an integrated, digital calibration interface and procedure, which makes the calibration process easy, accurate, and time-saving. No potentiometers or multi-meters required for the calibration. The calibration procedure requires significantly less calibration gas per calibration compared to traditional routines.

Electrical connection

Figure 2: Electrical connection

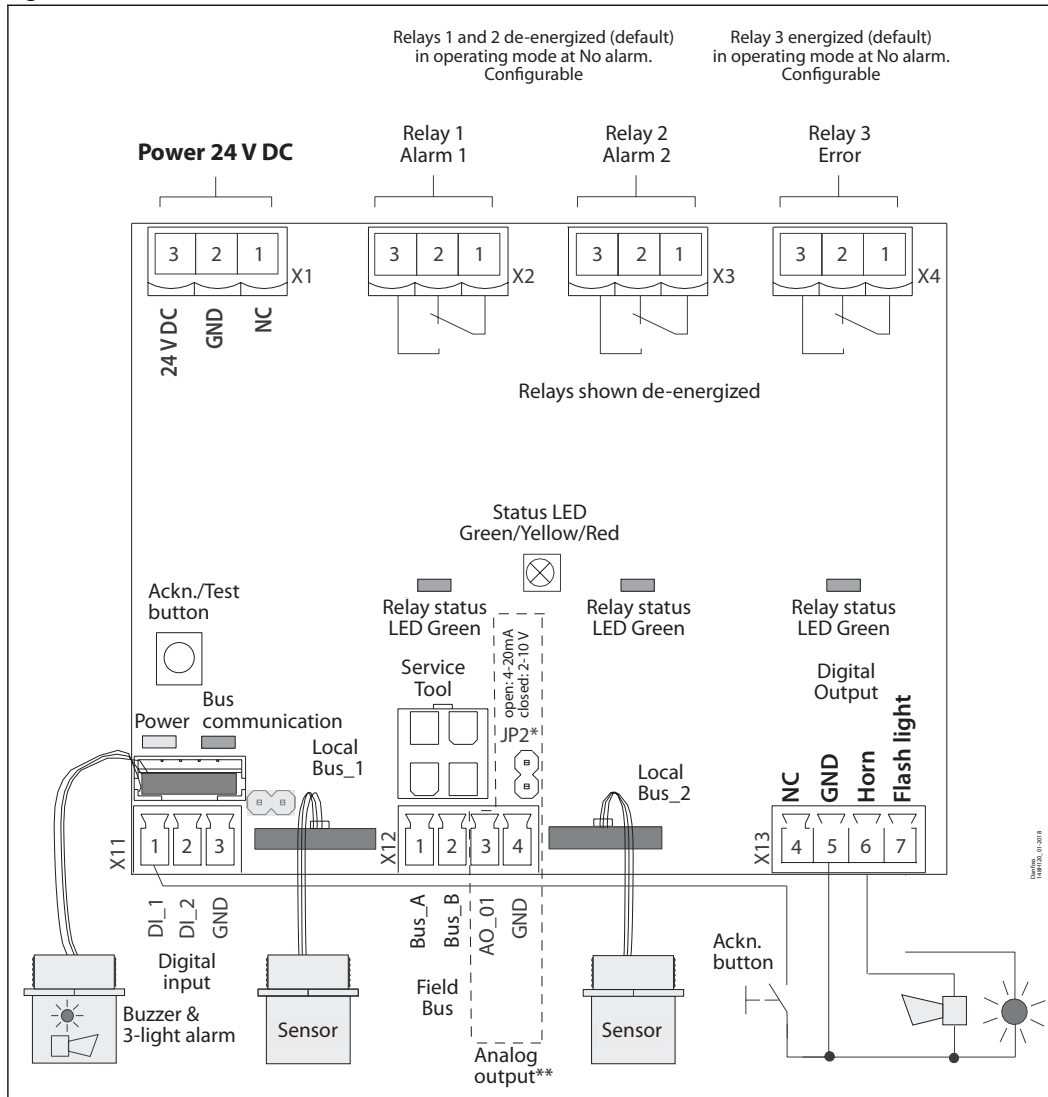

Status LED:

- GREEN is power on
 - flashing if maintenance needed
- YELLOW is an indicator of Error
 - when the sensor head is disconnected or not the expected type
 - AO is activated but nothing connected
- RED on alarm, similar to the Buzzer & light alarm.

Ackn. -/Test button:

- TEST
 - The button must be pressed for 20 sec.
 - Alarm1 and Alarm2 is simulated, stop on release
- ACKN
 - Pressed while Alarm2, the audible warning switches off and goes back on after 5 min. when the alarm situation is still active

* JP2 open → AO 4 – 20 mA (Default)

* JP2 closed → AO 2 – 10 Volt

NOTE:

** A resistor comes installed on the analog output connections – if analog output is used, remove the resistor.

Fieldbus loop

Each GD controller can handle up to 96 sensors and handle any mix of individual Gas detection units of the types Basic, Premium and Heavy Duty.

The max. recommended loop wire length is 900 meter (2953 ft) per segment.

With additional segments (and additional controller expansion modules) the max recommended loop wire length is 7200 meter 23622 ft).

The controller and the last GDU in each segment must be provided with a resistor of 560 Ohm. A U_{min} of 16 V DC must be secured at any spot in the loop.

Figure 3: how to make proper connections between the controller and each GDU

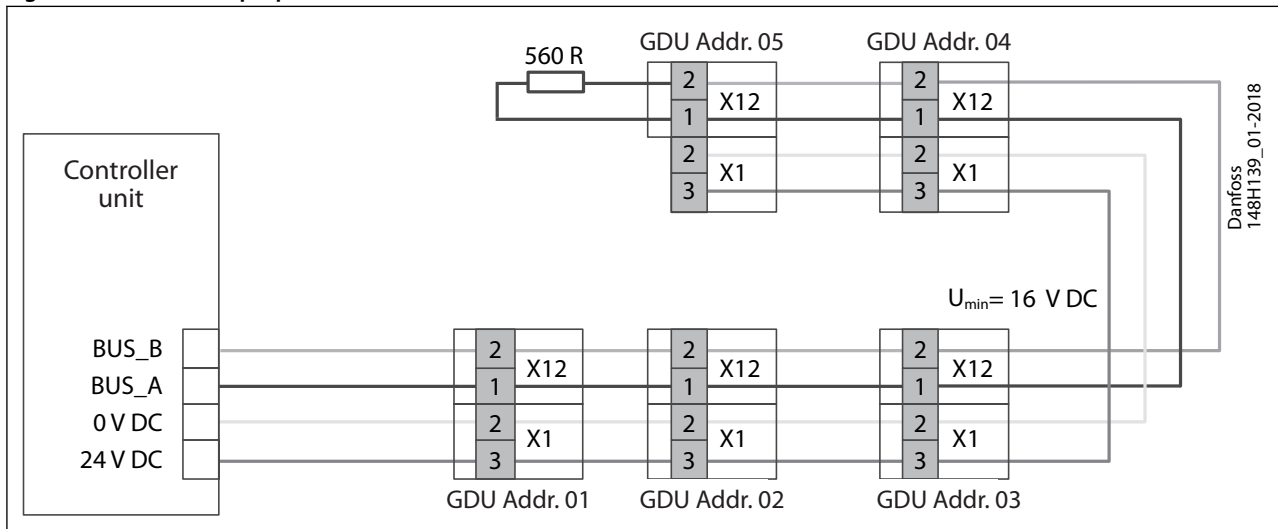
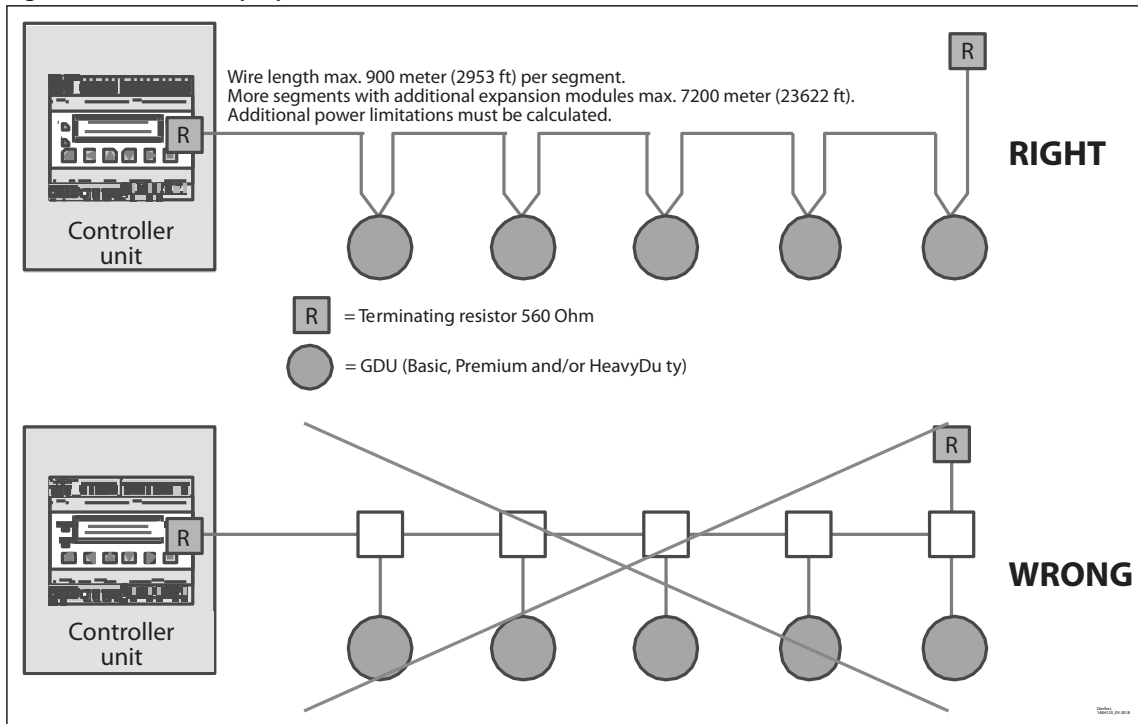
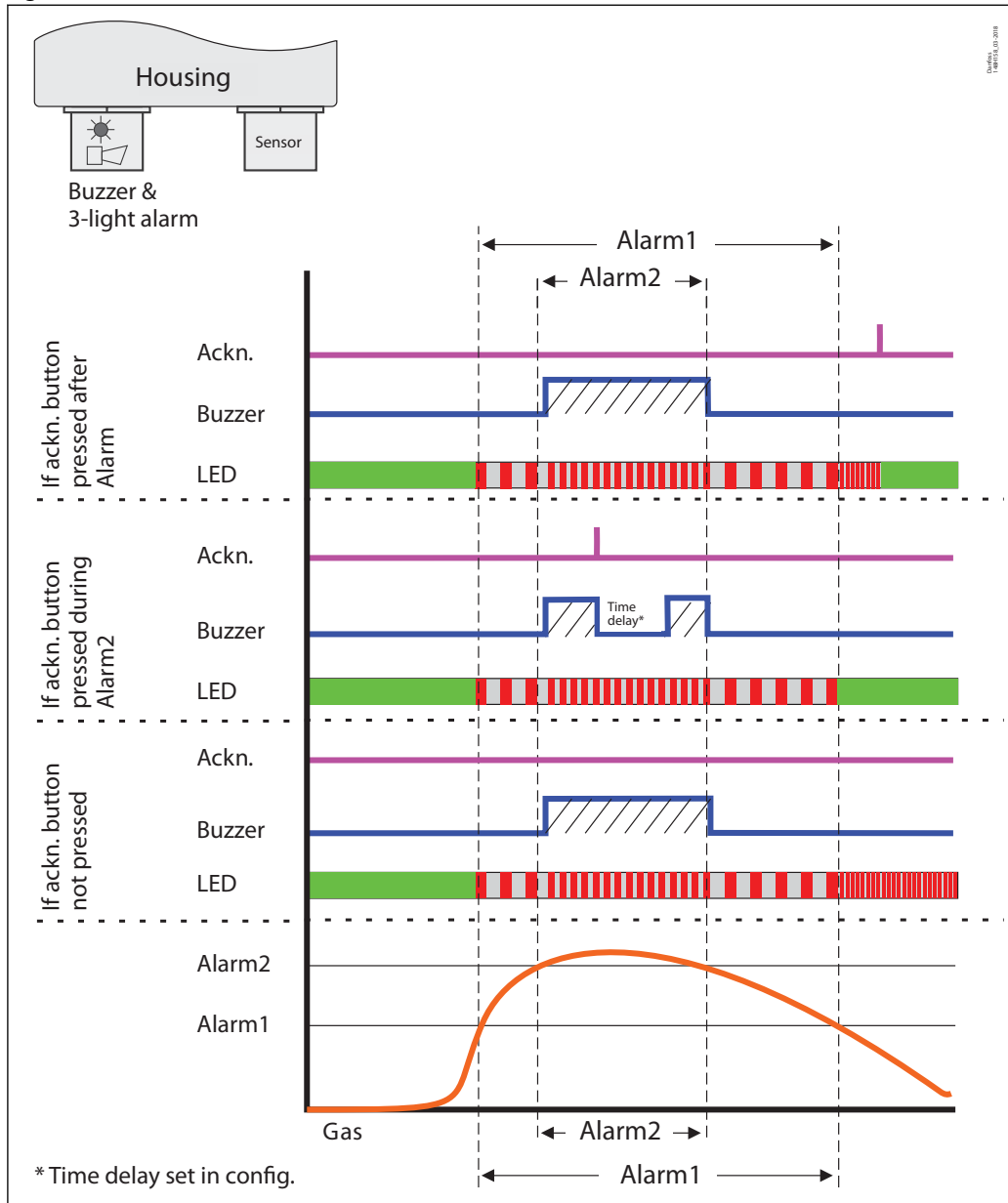

Figure 4: how to make proper connections between the controller and each GDU



Alarm scheme

Figure 5: Alarm scheme



Buzzer & light

	Blinking (2 sec.)
	Fast blinking (1 sec.)
	Very fast blinking (0.1 sec.)
	Buzzer on
	Static, Power LED

Ordering

Table 11: Ordering

Type	Description
Premium	Standard
Premium +	Standard + Buzzer & light warning device
Premium Duplex	Standard + 2nd sensor + Display and keyboard
Premium Remote	Remote sensor (stainless steel) with 5m cable (2nd cable gland needed) not mounted but enclosed + Display and keyboard
Premium Flex	Standard + Display and keyboard
Premium Uptime	Standard + Buzzer & light warning device + Display and keyboard + UPS

Table 12: Ordering standards

Type	Model	Refrigerant	Sensor	ppm range	Alarm ppm	2nd Sensor ppm (Alarm ppm)	Remote sensor ppm (Alarm ppm)	Buzzer & Light	Display	UPS	Temp. Range °C	Temp. Range °F	Code number	
GDA	Premium	Ammonia	Electrochemical	0 – 100	25/35						-30 to +50	-22 to 122	148H6002	
	Premium+	Ammonia	Electrochemical	0 – 100	25/35			x			-30 to +50	-22 to 122	148H6003	
	Premium Duplex	Ammonia	Electrochemical Pellistor	0 – 100	25/35	0 – 140000 (30000)			x		-20 to +50	-4 to 122	148H6004	
	Premium Remote	Ammonia	Electrochemical				0 – 100 (25/35)		x		-20 to +50	-4 to 122	148H6005	
	Premium Flex	Ammonia	Electrochemical	0 – 100	25/35				x		-20 to +50	-4 to 122	148H6006	
	Premium Uptime	Ammonia	Electrochemical	0 – 100	25/35			x	x	x	0 to +40	32 to 104	148H6007	
	Premium	Ammonia	Electrochemical	0 – 300	25/150							-30 to +50	-22 to 122	148H6010
	Premium+	Ammonia	Electrochemical	0 – 300	25/150				x			-30 to +50	-22 to 122	148H6011
	Premium Duplex	Ammonia	Electrochemical Pellistor	0 – 300	25/150	0 – 140000 (30000)				x		-20 to +50	-4 to 122	148H6012
	Premium Flex	Ammonia	Electrochemical	0 – 300	25/150					x		-20 to +50	-4 to 122	148H6013
	Premium	Ammonia	Electrochemical	0 – 1000	500/900							-30 to +50	-22 to 122	148H6016
	Premium+	Ammonia	Electrochemical	0 – 1000	500/900				x			-30 to +50	-22 to 122	148H6017
	Premium Duplex	Ammonia	Electrochemical Pellistor	0 – 1000	500/900	0 – 140000 (30000)				x		-20 to +50	-4 to 122	148H6018

Gas detection unit, Premium

Type	Model	Refrigerant	Sensor	ppm range	Alarm ppm	2nd Sensor ppm (Alarm ppm)	Remote sensor ppm (Alarm ppm)	Buzzer & Light	Display	UPS	Temp. Range °C	Temp. Range °F	Code number	
GDA	Premium Remote	Ammonia	Electro-chemical				0 – 1000 (500/900)		x		-20 to +50	-4 to 122	148H6019	
	Premium Flex	Ammonia	Electro-chemical	0 – 1000	500/900				x		-20 to +50	-4 to 122	148H6020	
	Premium Uptime	Ammonia	Electro-chemical	0 – 1000	500/900			x	x	x	0 to +40	32 to 104	148H6021	
	Premium	Ammonia	Semiconductor	0 – 1000	500/900							-10 to +50	14 to 122	148H6025
	Premium+	Ammonia	Semiconductor	0 – 1000	500/900			x				-10 to +50	14 to 122	148H6026
	Premium Flex	Ammonia	Semiconductor	0 – 1000	500/900				x			-10 to +50	14 to 122	148H6027
	Premium+	Ammonia	Electro-chemical	0 – 5000	1000/4500			x				-30 to +50	-22 to 122	148H6028
	Premium Remote	Ammonia	Electro-chemical				0 – 5000 (1000/4500)		x			-20 to +50	-4 to 122	148H6029
	Premium Uptime	Ammonia	Electro-chemical	0 – 5000	1000/4500			x	x	x		0 to +40	32 to 104	148H6030
	Premium	Ammonia	Semiconductor	0 – 10000	5000/9000							-10 to +50	14 to 122	148H6032
	Premium+	Ammonia	Semiconductor	0 – 10000	5000/9000			x				-10 to +50	14 to 122	148H6033
	Premium Remote	Ammonia	Semiconductor				0 – 10000 (5000/9000)		x			-10 to +50	14 to 122	148H6034
	Premium+	Ammonia	Pellistor	0 – 100% LEL (0 – 140000 ppm)	30000				x			-25 to +50	-13 to 122	148H6036
	Premium Duplex	Ammonia	Semiconductor Pellistor	0 – 1000	500/900	0 – 140000 (30000)			x			-10 to +50	14 to 122	148H6037
Premium Flex	Ammonia	Pellistor	0 – 100 % LEL (0 – 140000 ppm)	30000					x		-20 to +50	-4 to 122	148H6038	
GDC	Premium Flex	CO ₂	Infrared	0 – 2 % Vol (0 – 20000 ppm)	5000/9000				x		-20 to +50	-4 to 122	148H6040	
	Premium Flex	CO ₂	Infrared	0 – 5% Vol (0 – 50000 ppm)	10000/18000				x		-20 to +50	-4 to 122	148H6041	
GDHC	Premium	R123	Semiconductor	0 – 2000	500/900						-30 to +50	-22 to 122	148H6042	
	Premium+	R123	Semiconductor	0 – 2000	500/900			x	x		-30 to +50	-22 to 122	148H6043	
	Premium Flex	R123	Semiconductor	0 – 2000	500/900				x		-20 to +50	-4 to 122	148H6044	
GDHC	Premium Flex	R401a, R22, R401b, R402a, R402b, R403a, R408a, R409a, R411a	Semiconductor	0 – 2000	500/900				x		-20 to +50	-4 to 122	148H6062	
	Premium	R401a, R22, R401b, R402a, R402b, R403a, R408a, R409a, R411a	Semiconductor	0 – 2000	500/900						-30 to +50	-22 to 122	148H6063	

Gas detection unit, Premium

Type	Model	Refrigerant	Sensor	ppm range	Alarm ppm	2nd Sensor ppm (Alarm ppm)	Remote sensor ppm (Alarm ppm)	Buzzer & Light	Display	UPS	Temp. Range °C	Temp. Range °F	Code number
GDHF	Premium	R404a, R507a, R32, R125, R407c, R434a, R448a, R410a, R452b, R143b	Semiconductor	0 – 2000	500/900						-30 to +50	-22 to 122	148H6047
	Premium+	R404a, R507a, R32, R125, R407c, R434a, R448a, R410a, R452b, R143b	Semiconductor	0 – 2000	500/900			x			-30 to +50	-22 to 122	148H6048
	Premium Flex	R404a, R507a, R32, R125, R407c, R434a, R448a, R410a, R452b, R143b	Semiconductor	0 – 2000	500/900				x		-20 to +50	-4 to 122	148H6049
	Premium	R134a, R407a, R416a, R417a, R422a, R422d, R427a, R437a, R438a, R449a, R407f, R450a	Semiconductor	0 – 2000	500/900						-30 to +50	-22 to 122	148H6050
GDHF	Premium+	R134a, R407a, R416a, R417a, R422a, R422d, R427a, R437a, R438a, R449a, R407f, R450a	Semiconductor	0 – 2000	500/900			x			-30 to +50	-22 to 122	148H6051
	Premium Flex	R134a, R407a, R416a, R417a, R422a, R422d, R427a, R437a, R438a, R449a, R407f, R450a	Semiconductor	0 – 2000	500/900				x		-20 to +50	-4 to 122	148H6052

Gas detection unit, Premium

Type	Model	Refrigerant	Sensor	ppm range	Alarm ppm	2nd Sensor ppm (Alarm ppm)	Remote sensor ppm (Alarm ppm)	Buzzer & Light	Display	UPS	Temp. Range °C	Temp. Range °F	Code number
GDH	Premium	R290/ Propane R600 R600a	Pellistor	0 – 5000	800/2500						-30 to +50	-22 to 122	148H6053
	Premium+	R290/ Propane R600 R600a	Pellistor	0 – 5000	800/2500			x			-30 to +50	-22 to 122	148H6054
	Premium Flex	R290/ Propane R600 R600a	Pellistor	0 – 5000	800/2500				x		-20 to +50	-4 to 122	148H6055

Spare parts and accessories

Table 13: Spare parts and accessories

Description	Code number
Replacement sensor - Ammonia EC 100	148H6200
Replacement sensor - Ammonia EC 300	148H6201
Replacement sensor - Ammonia EC 1000	148H6202
Replacement sensor - Ammonia SC 1000	148H6203
Replacement sensor - Ammonia EC 5000	148H6204
Replacement sensor - Ammonia SC 10000	148H6205
Replacement sensor - Ammonia P LEL	148H6206
Replacement sensor - CO ₂ IR 20000	148H6207
Replacement sensor - CO ₂ IR 50000	148H6208
Replacement sensor - HCFC R123 SC 2000	148H6209
Replacement sensor HCFC R401a SC 2000	148H6243
Replacement sensor - HFC R404A, R507 SC 2000	148H6210
Replacement sensor - HFC R134a SC 2000	148H6211
Replacement sensor HCFC R401a SC 2000	148H6243
Replacement sensor - HC R290/Propane P 5000	148H6212
Remote sensor - Ammonia EC 100 (length: 5m (16.4 ft.) - External thread M30 x 1.5)	148H6213
Remote sensor - Ammonia EC 1000 (length: 5m (16.4 ft.) - External thread M30 x 1.5)	148H6214
Remote sensor - Ammonia EC 5000 (length: 5m (16.4 ft.) - External thread M30 x 1.5)	148H6215
Remote sensor - Ammonia SC 10000 (length: 5m (16.4 ft.) - External thread M30 x 1.5)	148H6216
Controller unit	148H6231
Controller solution (controller + enclosure)	148H6221
Uptime solution (UPS for controller)	148H6237
Controller expansion module	148H6222
Service tool	148H6224
PC Tool	148H6235
Calibration adapter	148H6232
Calibration adapter for remote sensors	148H6233
Buzzer & light - acoustic buzzer and optic led	148H6225
Air duct set	148H6236
Seal cap	148H6227
Remote kit	148H6238
Splash guard	148H6226
NPT adapter for remote sensor (M30 x 1.5 to NPT ¾ in.)	148H6234
Gateway for controller	148H6228
Display replacement for premium units	148H6250
Display replacement for Premium Uptime units	148H6251

Accessories overview

Controller unit

Gas detection unit, Premium

Used for a centralized monitoring and warning. The input signals for the controller are collected via RS485 Modbus or analog communication. The controller can handle up to 96 digital sensors via Fieldbus and four (4) analog input. An additional 28 analog input is possible using seven (7) expansion modules (4 – 20 mA signal interface). The total number of connected sensors should not exceed 128 sensors. The controller unit can be employed as pure analog controller, as analog/digital, or as digital controller. Configuration is menu-driven via the keypad. For fast and easy configuration, the PC Tool is recommended.

Controller solution

Controller unit placed in an enclosure ready to be connected to a power source. A separate UPS for the controller is available.

Controller expansion module

The gas detection Controller Expansion module is used for expansion of the cable coverage in terms of number of loops and the total wire length. Each Controller Unit can handle up to 7 Expansion modules allowing additional 7 segments with a total of 7200 meters (23622 ft.) wiring and a total of 32 relays for alarm device circuits.

Service tool

For interface with units with no display (Basic, Basic+, Premium, Premium+). Acts as a portable display and can be connected to all Danfoss gas detection units. (Heavy Duty w. adapter).

PC tool

The PC tool is a menu-driven and standalone software used for easy addressing, parameter setting, calibration, and data logging of the Basic, Premium and Heavy Duty gas detection units, and the controller unit.

Calibration adapter

The calibration adapter is required for connecting the calibration gas container, via the flow regulator, to the sensor head on the gas detection units. (Two variants, One for Basic and Premium plastic head sensors; one for heavy duty and Premium remote metal head sensors.).

Buzzer & light - acoustic buzzer and optic led

Can be installed in Basic or Premium units providing a local alarm.

Air duct set

The air duct set is specially designed to capture the airflow in air ducts. It can be connected to the standard sensor heads, except from Heavy Duty gas detection units.

Seal cap

Airtight seal cap to protect the sensor head against premature exposure during installation. The seal cap is mounted on new sensors (complete units and replacement sensors) but is also available as an accessory.

Remote kit

Enabling installation of a sensor head in plastic housing 5m (16.4 ft.) from the unit. This means that the gas detection unit can be placed outside the room where the sensor is placed to detect hazardous gases, allowing reading of and interfacing with the unit without entering the dedicated space. Basic and Premium gas detection units.

Splash guard

To protect the sensor head against water exposure during wash-down cleaning and rinsing operations.

NPT adapter

The NPT adapter is a steel fitting for installation of remote sensors into NPT threads; it converts the standards M30 X 1.5 thread of the Stainless Steel remote sensor head into an External NPT 3/4" thread for more convenient installation.

Gateway for controller

The gateway is an addition to the controller and used for communicating via Modbus TCP/IP.

Certificates, declarations and approvals

The list contains all certificates, declarations, and approvals for this product type. Individual code number may have some or all of these approvals, and certain local approvals may not appear on the list.

Some approvals may change over time. You can check the most current status at danfoss.com or contact your local Danfoss representative if you have any questions.

Table 14: Valid Approvals

Type	File name	Document type	Document topic	Approval authority
GD	500000219230.AA	Manufacturers Declaration	Similarity	Danfoss
GDA	148R6115.AA	EU Declaration	EMCD/LVD	Danfoss

Table 15: Compliance

	EMC directives 2014/30/EU
	Low voltage directive 2014/35/EU
	Conformity to EN 50271, EN 61010-1
	ETL listed to UL 61010-1 and CSA C22.2 No.61010-1
	Enables regulatory compliance with EN 378:2016, ISO 5149:2014, IAR 2-2017, and ASHRAE 15:2016

Online support

Danfoss offers a wide range of support along with our products, including digital product information, software, mobile apps, and expert guidance. See the possibilities below.

The Danfoss Product Store



The Danfoss Product Store is your one-stop shop for everything product related—no matter where you are in the world or what area of the cooling industry you work in. Get quick access to essential information like product specs, code numbers, technical documentation, certifications, accessories, and more.

Start browsing at store.danfoss.com.

Find technical documentation



Find the technical documentation you need to get your project up and running. Get direct access to our official collection of data sheets, certificates and declarations, manuals and guides, 3D models and drawings, case stories, brochures, and much more.

Start searching now at www.danfoss.com/en/service-and-support/documentation.

Danfoss Learning



Danfoss Learning is a free online learning platform. It features courses and materials specifically designed to help engineers, installers, service technicians, and wholesalers better understand the products, applications, industry topics, and trends that will help you do your job better.

Create your Danfoss Learning account for free at www.danfoss.com/en/service-and-support/learning.

Get local information and support



Local Danfoss websites are the main sources for help and information about our company and products. Find product availability, get the latest regional news, or connect with a nearby expert—all in your own language.

Find your local Danfoss website here: www.danfoss.com/en/choose-region.

Spare Parts



Get access to the Danfoss spare parts and service kit catalog right from your smartphone. The app contains a wide range of components for air conditioning and refrigeration applications, such as valves, strainers, pressure switches, and sensors.

Download the Spare Parts app for free at www.danfoss.com/en/service-and-support/downloads.

Danfoss A/S

Climate Solutions • danfoss.com • +45 7488 2222

Any information, including, but not limited to information on selection of product, its application or use, product design, weight, dimensions, capacity or any other technical data in product manuals, catalogues descriptions, advertisements, etc. and whether made available in writing, orally, electronically, online or via download, shall be considered informative, and is only binding if and to the extent, explicit reference is made in a quotation or order confirmation. Danfoss cannot accept any responsibility for possible errors in catalogues, brochures, videos and other material. Danfoss reserves the right to alter its products without notice. This also applies to products ordered but not delivered provided that such alterations can be made without changes to form, fit or function of the product.

All trademarks in this material are property of Danfoss A/S or Danfoss group companies. Danfoss and the Danfoss logo are trademarks of Danfoss A/S. All rights reserved.