

Data sheet

Check valve

Types NRV and NRVH



NRV and NRVH can be used in liquid suction and hot gas lines in refrigeration and air conditioning plants.

The valves ensure the correct flow direction and prevent back-condensation from a warm part of the system to the cold evaporator.

The hermetic tight design of solder versions meet the environmental demands for today and future.

A built-in damping piston makes the valves suitable for installation in lines where pulsation can occur, e. g. in the discharge line from the compressor.

Features

- Ensure correct flow direction
- Available in both straightway and angleway versions
- Prevents back-condensation from warm to cold system part
- Solder versions are compliant with ATEX hazard zone 2
- Hermetic tight design for solder versions
- Built-in damping piston that makes the valves suitable for installation in lines where pulsation can occur, e.g. in the discharge line from the compressor
- NRVH type check valve is with stronger spring and it's recommended to use for compressors in parallel (i.e. power packs) where higher level of pulsation and vibration are expected
- Oversize connections provide flexibility in use

Data sheet | Check valve, types NRV and NRVH

Approvals



Technical data

Refrigerants	R134a, R22/R407C, R404A/R507, R407A, R407F, R410A, R32, R290, R600, R600a, R1270, R448A, R449A, R450A, R452A, R452B, R454B, R513A, R1234ze, R1234yf
Media temperature range	-50 – 140 °C / -58 – 285 °F
Max. working pressure (PS/MWP)	46 bar / 667 psig



Note: Only solder version, connection sizes from 6 s to 22 s are allowed for flammable refrigerant

- This product is approved for R290, R600, R600a and R1270 by ignition source assessment in accordance to standard EN13463-1. R1234ze can be used for NRV size up to 35s according to the PED category I, Fluid II
- For a fully updated list of approved refrigerants, visit www.products.danfoss.com and search for individual code numbers, where refrigerants are listed as part of product specifications

Dimensioning and selection

When selecting the right Danfoss check valve the capacity tables should be utilised together with plant requirements concerning piping and connection sizes. The optimum solution should include the highest capacity at lowest pressure drop across the valve before it closes. Further, when dimensioning and selecting Danfoss check valves for mounting into the compressor discharge line, it is important to be aware of the following:

The differential pressure across the valve must always be higher than the given minimum pressure drop at which the valve is completely open. This also applies to lowest capacities for compressor with capacity regulation.

NRVH type check valve is with stronger spring and it's recommended to use for compressors in parallel (i.e. power packs) where higher level of pulsation and vibration are expected.

Ordering



Straightway Flare Version without flare nut

Valve type	Connection type	Connection		Pressure drop across valve Δp ²⁾		K _v value ³⁾ (calculated value)	C _v value ³⁾ (calculated value)	Code no.
		[in]	[mm]	[bar]	[psi]	[m ³ /h]	[gal/min]	
NRV 6	Straight-way - flare	1/4	6	0.07	1.01	0.56	0.65	020-1040
NRV 10	Straight-way - flare	3/8	10	0.07	1.01	1.2	1.39	020-1041
NRV 12	Straight-way - flare	1/2	12	0.05	0.72	2.05	2.37	020-1042
NRV 16	Straight-way - flare	5/8	16	0.05	0.72	3.6	4.16	020-1043
NRV 19	Straight-way - flare	3/4	19	0.05	0.72	5.5	6.36	020-1044

Angleway Solder ODF Version

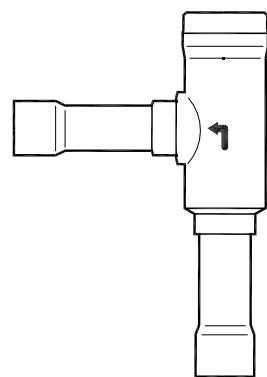

Valve type	Connection type	Connection		Pressure drop across valve Δp ²⁾		K _v value ³⁾ (calculated value)	C _v value ³⁾ (calculated value)	Code no.
		[in]	[mm]	[bar]	[psi]	[m ³ /h]	[gal/min]	
NRV 22s	Angle-way - solder	7/8	22	0.04	0.58	8.5	9.83	020-1020
NRVH 22s	Angle-way - solder	7/8	22	0.30	4.35	8.5	9.83	020-1032
NRV 22s ¹⁾	Angle-way - solder	1 1/8	–	0.04	0.58	8.5	9.83	020-1060
	Angle-way - solder	–	28	0.04	0.58	8.5	9.83	020-1055
NRVH 22s ¹⁾	Angle-way - solder	1 1/8	–	0.30	4.35	8.5	9.83	020-1072
	Angle-way - solder	–	28	0.30	4.35	8.5	9.83	020-1067
NRV 28s	Angle-way - solder	1 1/8	–	0.04	0.58	16.5	19.07	020-1021
	Angle-way - solder	–	28	0.04	0.58	16.5	19.07	020-1025
NRVH 28s	Angle-way - solder	1 1/8	–	0.30	4.35	16.5	19.07	020-1029
	Angle-way - solder	–	28	0.30	4.35	16.5	19.07	020-1033
NRV 28s ¹⁾	Angle-way - solder	1 3/8	35	0.04	0.58	16.5	19.07	020-1056
NRVH 28s ¹⁾	Angle-way - solder	1 3/8	35	0.30	4.35	16.5	19.07	020-1068
NRV 35s	Angle-way - solder	1 3/8	35	0.04	0.58	29	33.52	020-1026
NRVH 35s	Angle-way - solder	1 3/8	35	0.30	4.35	29	33.52	020-1034
NRV 35s ¹⁾	Angle-way - solder	1 3/8	–	0.04	0.58	29	33.52	020-1061
	Angle-way - solder	–	42	0.04	0.58	29	33.52	020-1027
NRVH 35s ¹⁾	Angle-way - solder	1 5/8	–	0.30	4.35	29	33.52	020-1073
	Angle-way - solder	–	42	0.30	4.35	29	33.52	020-1035

¹⁾ Oversize connections

²⁾ Δp = the minimum pressure at which the valve is completely open

The NRVH with a stronger spring is used in the discharge line from compressors connected in parallel

³⁾ The K_v / C_v value is the flow of water in [m³/h – gal/min] at a pressure drop across valve of 1 bar/14.5 psig
 $\rho = 1000 \text{ kg/m}^3 - 2205 \text{ lbs/G}$

Data sheet | Check valve, types NRV and NRVH

Ordering (continued)



Straightway Solder ODF Version

Valve type	Connection type	Connection		Pressure drop across valve Δp ²⁾		K _v value ³⁾ (calculated value)	C _v value ³⁾ (calculated value)	Code no.
		[in]	[mm]	[bar]	[psi]	[m ³ /h]	[gal/min]	
NRV 6s	Straight-way - Solder	1/4	–	0.07	1.01	0.56	0.65	020-1010
	Straight-way - Solder	–	6	0.07	1.01	0.56	0.65	020-1014
NRV 6s ¹⁾	Straight-way - Solder	3/8	–	0.07	1.01	0.56	0.65	020-1057
	Straight-way - Solder	–	10	0.07	1.01	0.56	0.65	020-1050
NRVH 6s ¹⁾	Straight-way - Solder	3/8	–	0.30	4.35	0.56	0.65	020-1069
	Straight-way - Solder	–	10	0.30	4.35	0.56	0.65	020-1062
NRV 10s	Straight-way - Solder	3/8	–	0.07	1.01	1.20	1.39	020-1011
	Straight-way - Solder	–	10	0.07	1.01	1.20	1.39	020-1015
NRVH 10s	Straight-way - Solder	3/8	–	0.30	4.35	1.20	1.39	020-1046
	Straight-way - Solder	–	10	0.30	4.35	1.20	1.39	020-1036
NRV 10s ¹⁾	Straight-way - Solder	1/2	–	0.07	1.01	1.20	1.39	020-1058
	Straight-way - Solder	–	12	0.07	1.01	1.20	1.39	020-1051
NRVH 10s ¹⁾	Straight-way - Solder	1/2	–	0.30	4.35	1.20	1.39	020-1070
	Straight-way - Solder	–	12	0.30	4.35	1.20	1.39	020-1063
NRV 12s	Straight-way - Solder	1/2	–	0.05	0.72	2.05	2.37	020-1012
	Straight-way - Solder	–	12	0.05	0.72	2.05	2.37	020-1016
NRVH 12s	Straight-way - Solder	1/2	–	0.30	4.35	2.05	2.37	020-1039
	Straight-way - Solder	–	12	0.30	4.35	2.05	2.37	020-1037
NRV 12s ¹⁾	Straight-way - Solder	5/8	16	0.05	0.72	2.05	2.37	020-1052
NRVH 12s ¹⁾	Straight-way - Solder	5/8	16	0.30	4.35	2.05	2.37	020-1064
NRV 16s	Straight-way - Solder	5/8	16	0.05	0.72	3.60	4.16	020-1018
NRVH 16s	Straight-way - Solder	5/8	16	0.30	4.35	3.60	4.16	020-1038
NRV 16s ¹⁾	Straight-way - Solder	–	18	0.05	0.72	3.60	4.16	020-1053
NRVH 16s ¹⁾	Straight-way - Solder	–	18	0.30	4.35	3.60	4.16	020-1065
NRV 16s ¹⁾	Straight-way - Solder	3/4	19	0.05	0.72	3.60	4.16	020-1059
NRVH 16s ¹⁾	Straight-way - Solder	3/4	19	0.30	4.35	3.60	4.16	020-1071
NRV 19s	Straight-way - Solder	–	18	0.05	0.72	5.50	6.36	020-1017
NRVH 19s	Straight-way - Solder	–	18	0.30	4.35	5.50	6.36	020-1008
NRV 19s	Straight-way - Solder	3/4	19	0.05	0.72	5.50	6.36	020-1019
NRVH 19s	Straight-way - Solder	3/4	19	0.30	4.35	5.50	6.36	020-1023
NRV 19s ¹⁾	Straight-way - Solder	7/8	22	0.05	0.72	5.50	6.36	020-1054
NRVH 19s ¹⁾	Straight-way - Solder	7/8	22	0.30	4.35	5.50	6.36	020-1066

¹⁾ Oversize connections

²⁾ Δp = the minimum pressure at which the valve is completely open

The NRVH with a stronger spring is used in the discharge line from compressors connected in parallel

³⁾ The K_v/C_v value is the flow of water in [m³/h – gal/min] at a pressure drop across valve of 1 bar/14.5 psig
 $\rho = 1000 \text{ kg/m}^3 - 2205 \text{ lbs/G}$

Data sheet | Check valve, types NRV and NR VH

SI units

Capacity

Liquid capacity (kW)

Type	Liquid capacity ¹⁾ at pressure drop across valve Δp [bar]			
	NRV			NRV/ NRVH
	0.05	0.07	0.14	0.3 ²⁾

R22

NRV/NRVH 6	-	7.70	10.9	15.9
NRV/NRVH 10	-	16.5	23.3	34.1
NRV/NRVH 12	23.8	28.2	39.8	58.3
NRV/NRVH 16	41.8	49.5	70.0	102
NRV/NRVH 19	63.9	75.6	107	157
NRV/NRVH 22	98.7	117	165	242
NRV/NRVH 28	192	227	321	469
NRV/NRVH 35	337	399	564	825

R134a

NRV/NRVH 6	-	7.10	10.1	14.7
NRV/NRVH 10	-	15.3	21.6	31.6
NRV/NRVH 12	22.0	26.1	36.9	53.9
NRV/NRVH 16	38.7	45.8	64.7	94.7
NRV/NRVH 19	59.1	69.9	98.9	145
NRV/NRVH 22	91.3	108	153	224
NRV/NRVH 28	177	300	297	434
NRV/NRVH 35	312	369	521	763

R404A/R507

NRV/NRVH 6	-	5.20	7.40	10.8
NRV/NRVH 10	-	11.2	15.8	23.1
NRV/NRVH 12	16.1	19.1	27.0	39.5
NRV/NRVH 16	28.3	33.5	47.4	69.3
NRV/NRVH 19	43.2	51.2	72.4	106
NRV/NRVH 22	66.8	79.1	112	164
NRV/NRVH 28	130	154	217	318
NRV/NRVH 35	228	270	382	559

¹⁾ Rated liquid capacities are based on:

- Evaporating temperature, $t_e = -10^\circ\text{C}$
- Condensing temperature, $t_c = 30^\circ\text{C}$
- Subcooling $\Delta t_{\text{sub}} = 5\text{ K}$

²⁾ Capacity for NR VH

The table values refer to the evaporator capacity

Suction vapour capacity (kW)

Type	Pressure drop across valve Δp [bar]	Suction vapour capacity ¹⁾ at evaporating temperature t_e [$^\circ\text{C}$]			
		-30	-10	0	5

R22

NRV/NRVH 6	0.07	0.56	0.86	1.04	1.14
NRV/NRVH 10	0.07	1.20	1.85	2.23	2.44
NRV/NRVH 12	0.05	1.75	2.67	3.23	3.53
NRV/NRVH 16	0.05	3.07	4.70	5.67	6.19
NRV/NRVH 19	0.05	4.68	7.18	8.66	9.46
NRV/NRVH 22	0.05	7.24	11.1	13.4	14.6
NRV/NRVH 28	0.05	14.1	21.5	26.0	28.4
NRV/NRVH 35	0.05	24.7	37.83	45.7	49.9

R134a

NRV/NRVH 6	0.07	0.38	0.63	0.80	0.89
NRV/NRVH 10	0.07	0.80	1.36	1.71	1.90
NRV/NRVH 12	0.05	1.18	1.98	2.47	2.75
NRV/NRVH 16	0.05	2.07	3.47	4.34	4.83
NRV/NRVH 19	0.05	3.17	5.30	6.64	7.37
NRV/NRVH 22	0.05	4.89	8.20	10.2	11.4
NRV/NRVH 28	0.05	9.50	15.9	19.9	22.1
NRV/NRVH 35	0.05	16.7	28.0	35.0	38.9

R404A/R507

NRV/NRVH 6	0.07	0.47	0.75	0.92	1.02
NRV/NRVH 10	0.07	1.00	1.61	1.98	2.18
NRV/NRVH 12	0.05	1.46	2.33	2.86	3.15
NRV/NRVH 16	0.05	2.56	4.08	5.02	5.54
NRV/NRVH 19	0.05	3.91	6.24	7.67	8.46
NRV/NRVH 22	0.05	6.05	9.64	11.9	13.1
NRV/NRVH 28	0.05	11.7	18.7	23.0	25.4
NRV/NRVH 35	0.05	20.6	32.9	40.5	44.6

¹⁾ Rated suction vapour capacities are based on:

- Suction superheat $sh = 0\text{ K}$
- Condensing temperature, $t_c = 30^\circ\text{C}$
- Subcooling $\Delta t_{\text{sub}} = 5\text{ K}$

The table values refer to the evaporator capacity

Hot gas capacity (kW)

Type	Hot gas capacity ¹⁾ at pressure drop across valve Δp [bar]			
	NRV			NRV/ NRVH
	0.05	0.07	0.14	0.3 ²⁾

R22

NRV/NRVH 6	-	1.40	2.00	2.80
NRV/NRVH 10	-	3.00	4.20	6.10
NRV/NRVH 12	4.3	5.10	7.20	10.0
NRV/NRVH 16	7.6	8.90	12.6	18.3
NRV/NRVH 19	11.5	13.6	19.2	27.9
NRV/NRVH 22	17.8	21.1	29.7	43.1
NRV/NRVH 28	34.6	40.9	57.7	83.7
NRV/NRVH 35	60.9	71.9	101	147

R134a

NRV/NRVH 6	-	1.1	1.6	2.2
NRV/NRVH 10	-	2.4	3.3	4.8
NRV/NRVH 12	3.4	4.0	5.7	8.2
NRV/NRVH 16	6.0	7.1	10.0	14.4
NRV/NRVH 19	9.2	10.8	15.2	22.0
NRV/NRVH 22	14.2	16.8	23.6	34.0
NRV/NRVH 28	27.5	32.5	45.7	66.0
NRV/NRVH 35	48.4	57.2	80.4	116

R404A/R507

NRV/NRVH 6	-	1.2	1.7	2.4
NRV/NRVH 10	-	2.6	3.6	5.2
NRV/NRVH 12	3.70	4.4	6.2	9.0
NRV/NRVH 16	6.50	7.7	10.8	15.7
NRV/NRVH 19	9.90	11.7	16.6	24.1
NRV/NRVH 22	15.3	18.1	25.6	37.2
NRV/NRVH 28	29.8	35.2	49.7	72.2
NRV/NRVH 35	52.4	61.9	87.3	127

¹⁾ Rated hot gas capacities are based on:

- Evaporating temperature, $t_e = -10^\circ\text{C}$
- Condensing temperature, $t_c = 30^\circ\text{C}$
- Subcooling $\Delta t_{\text{sub}} = 5\text{ K}$
- Hot gas temperature, $t_h = 60^\circ\text{C}$ ahead of the valve
- Discharge temperature, $t_d = 80^\circ\text{C}$ after compressor

²⁾ Capacity for NR VH

The table values refer to the evaporator capacity

Correction factors

When selecting the evaporator capacity is to be multiplied by a correction factor depending on the liquid temperature t_l ahead of the valve/the evaporator. The corrected capacity can then be found from the table.

Correction factors for liquid temperature t_l

t_l [$^\circ\text{C}$]	-10	0	10	15	20	25	30	35	40	45	50
R22	0.77	0.82	0.88	0.92	0.96	1.00	1.05	1.10	1.16	1.22	1.30
R134a	0.73	0.79	0.86	0.90	0.95	1.00	1.06	1.12	1.19	1.28	1.37
R404A/R507	0.67	0.74	0.82	0.87	0.93	1.00	1.08	1.17	1.29	1.43	1.61

Data sheet | Check valve, types NRV and NR VH

Capacity

SI units

Liquid capacity (kW)

Type	Liquid capacity ¹⁾ at pressure drop across valve Δp [bar]			
	NRV			NRV/ NRVH
	0.05	0.07	0.14	0.3 ²⁾

R407A

NRV/NRVH 6	-	6.80	9.60	14.10
NRV/NRVH 10	-	14.6	20.6	30.2
NRV/NRVH 12	21.0	24.9	35.2	51.5
NRV/NRVH 16	37.0	43.7	61.8	90.5
NRV/NRVH 19	56.5	66.8	94.5	138
NRV/NRVH 22	87.2	103	146	214
NRV/NRVH 28	169	200	283	415
NRV/NRVH 35	298	352	498	729

R407C

NRV/NRVH 6	-	7.30	10.4	15.2
NRV/NRVH 10	-	15.7	22.2	32.6
NRV/NRVH 12	22.7	26.9	38.0	55.6
NRV/NRVH 16	39.9	47.2	66.7	97.7
NRV/NRVH 19	60.9	72.1	102	149
NRV/NRVH 22	94.2	111	158	231
NRV/NRVH 28	183	216	306	448
NRV/NRVH 35	321	380	538	787

R407F

NRV/NRVH 6	-	7.50	10.6	15.5
NRV/NRVH 10	-	16.1	22.8	33.3
NRV/NRVH 12	23.2	27.5	38.9	56.9
NRV/NRVH 16	40.8	48.3	68.3	99.9
NRV/NRVH 19	62.3	73.8	104	153
NRV/NRVH 22	96.3	114	161	236
NRV/NRVH 28	187	221	313	458
NRV/NRVH 35	329	389	550	805

¹⁾ Rated liquid capacities are based on:

- Evaporating temperature, $t_e = -10\text{ °C}$
- Condensing temperature, $t_c = 30\text{ °C}$
- Subcooling $\Delta t_{sub} = 5\text{ K}$

²⁾ Capacity for NR VH

The table values refer to the evaporator capacity

Suction vapour capacity (kW)

Type	Pressure drop across valve Δp [bar]	Suction vapour capacity ¹⁾ at evaporating temperature t_e [°C]			
		-30	-10	0	5

R407A

NRV/NRVH 6	0.07	0.49	0.79	0.97	1.08
NRV/NRVH 10	0.07	1.04	1.69	2.09	2.30
NRV/NRVH 12	0.05	1.52	2.45	3.02	3.33
NRV/NRVH 16	0.05	2.67	4.30	5.30	5.85
NRV/NRVH 19	0.05	4.07	6.57	8.10	8.94
NRV/NRVH 22	0.05	6.30	10.2	12.52	13.8
NRV/NRVH 28	0.05	12.2	19.7	24.3	26.8
NRV/NRVH 35	0.05	21.5	34.6	42.7	47.2

R407C

NRV/NRVH 6	0.07	0.49	0.80	0.99	1.09
NRV/NRVH 10	0.07	1.06	1.71	2.11	2.33
NRV/NRVH 12	0.05	1.54	2.48	3.06	3.37
NRV/NRVH 16	0.05	2.70	4.36	5.37	5.93
NRV/NRVH 19	0.05	4.13	6.65	8.20	9.05
NRV/NRVH 22	0.05	6.38	10.3	12.7	14.0
NRV/NRVH 28	0.05	12.4	20.0	24.6	27.2
NRV/NRVH 35	0.05	21.8	35.1	43.2	47.7

R407F

NRV/NRVH 6	0.07	0.54	0.87	1.06	1.17
NRV/NRVH 10	0.07	1.16	1.85	2.27	2.50
NRV/NRVH 12	0.05	1.69	2.69	3.29	3.62
NRV/NRVH 16	0.05	2.97	4.72	5.77	6.35
NRV/NRVH 19	0.05	4.54	7.21	8.82	9.70
NRV/NRVH 22	0.05	7.02	11.1	13.6	15.0
NRV/NRVH 28	0.05	13.6	21.6	26.5	29.1
NRV/NRVH 35	0.05	24.0	38.0	46.5	51.2

¹⁾ Rated suction vapour capacities are based on:

- Suction superheat $sh = 0\text{ K}$
- Condensing temperature, $t_c = 30\text{ °C}$
- Subcooling $\Delta t_{sub} = 5\text{ K}$

The table values refer to the evaporator capacity

Hot gas capacity (kW)

Type	Hot gas capacity ¹⁾ at pressure drop across valve Δp [bar]			
	NRV			NRV/ NRVH
	0.05	0.07	0.14	0.3 ²⁾

R407A

NRV/NRVH 6	-	1.40	2.00	2.90
NRV/NRVH 10	-	3.00	4.30	6.20
NRV/NRVH 12	4.40	5.20	7.30	10.6
NRV/NRVH 16	7.70	9.10	12.9	18.7
NRV/NRVH 19	11.8	13.9	19.7	28.6
NRV/NRVH 22	18.2	21.5	30.4	44.1
NRV/NRVH 28	35.4	41.8	59.0	85.7
NRV/NRVH 35	62.2	73.5	104	151

R407C

NRV/NRVH 6	-	1.50	2.10	3.00
NRV/NRVH 10	-	3.10	4.40	6.40
NRV/NRVH 12	4.50	5.40	7.60	11.0
NRV/NRVH 16	8.00	9.40	13.3	19.3
NRV/NRVH 19	12.2	14.4	20.3	29.4
NRV/NRVH 22	18.8	22.2	31.3	45.5
NRV/NRVH 28	36.5	43.1	60.8	88.3
NRV/NRVH 35	64.1	75.8	107	155

R407F

NRV/NRVH 6	-	1.50	2.20	3.20
NRV/NRVH 10	-	3.30	4.70	6.80
NRV/NRVH 12	4.80	5.70	8.00	11.6
NRV/NRVH 16	8.40	9.90	14.0	20.4
NRV/NRVH 19	12.8	15.2	21.4	31.1
NRV/NRVH 22	19.8	23.5	33.1	48.1
NRV/NRVH 28	38.5	45.5	64.2	93.4
NRV/NRVH 35	67.7	80.0	113	164

¹⁾ Rated hot gas capacities are based on:

- Evaporating temperature, $t_e = -10\text{ °C}$
- Condensing temperature, $t_c = 30\text{ °C}$
- Subcooling $\Delta t_{sub} = 5\text{ K}$
- Hot gas temperature, $t_h = 60\text{ °C}$ ahead of the valve
- Discharge temperature, $t_d = 80\text{ °C}$ after compressor

²⁾ Capacity for NR VH

The table values refer to the evaporator capacity

Correction factors

When selecting the evaporator capacity is to be multiplied by a correction factor depending on the liquid temperature t_l ahead of the valve/the evaporator. The corrected capacity can then be found from the table.

Correction factors for liquid temperature t_l

t_l [°C]	-10	0	10	15	20	25	30	35	40	45	50
R407A	0.71	0.78	0.85	0.90	0.94	1.00	1.06	1.13	1.22	1.32	1.43
R407C	0.73	0.79	0.86	0.90	0.95	1.00	1.06	1.13	1.20	1.29	1.40
R407F	0.73	0.79	0.86	0.90	0.95	1.00	1.06	1.12	1.20	1.29	1.39

Data sheet | Check valve, types NRV and NR VH

SI units

Capacity

Liquid capacity (kW)

Type	Liquid capacity ¹⁾ at pressure drop across valve Δp [bar]			
	NRV			NRV/ NRVH
	0.05	0.07	0.14	0.3 ²⁾

R410A

Type	0.05	0.07	0.14	0.3 ²⁾
NRV/NRVH 6	–	7.50	10.7	15.6
NRV/NRVH 10	–	16.2	22.9	33.5
NRV/NRVH 12	23.3	27.6	39.1	57.2
NRV/NRVH 16	41.0	48.5	68.6	100
NRV/NRVH 19	62.6	74.1	105	153
NRV/NRVH 22	96.8	115	162	237
NRV/NRVH 28	188	222	314	460
NRV/NRVH 35	330	391	552	809

R448A

Type	0.05	0.07	0.14	0.3 ²⁾
NRV/NRVH 6	–	6.80	9.70	14.2
NRV/NRVH 10	–	14.7	20.7	30.3
NRV/NRVH 12	21.2	25.0	35.4	51.8
NRV/NRVH 16	37.1	44.0	62.2	91.0
NRV/NRVH 19	56.7	67.1	95.0	139
NRV/NRVH 22	87.7	104	147	215
NRV/NRVH 28	170	201	285	417
NRV/NRVH 35	299	354	501	733

R449A

Type	0.05	0.07	0.14	0.3 ²⁾
NRV/NRVH 6	–	6.70	9.50	13.9
NRV/NRVH 10	–	14.4	20.3	29.8
NRV/NRVH 12	20.8	24.6	34.7	50.9
NRV/NRVH 16	36.5	43.2	61.0	89.3
NRV/NRVH 19	55.7	65.9	93.2	136.5
NRV/NRVH 22	86.1	102	144	211
NRV/NRVH 28	167	198	280	409
NRV/NRVH 35	294	348	492	720

¹⁾ Rated liquid capacities are based on:

- Evaporating temperature, $t_e = -10\text{ °C}$
- Condensing temperature, $t_c = 30\text{ °C}$
- Subcooling $\Delta t_{sub} = 5\text{ K}$

²⁾ Capacity for NR VH

The table values refer to the evaporator capacity

Suction vapour capacity (kW)

Type	Pressure drop across valve Δp [bar]	Suction vapour capacity ¹⁾ at evaporating temperature t_e [°C]			
		-30	-10	0	5

R410A

Type	0.07	0.05	0.05	0.05	0.05
NRV/NRVH 6	0.07	0.71	1.08	1.30	1.41
NRV/NRVH 10	0.07	1.52	2.31	2.78	3.03
NRV/NRVH 12	0.05	2.20	3.34	4.02	4.38
NRV/NRVH 16	0.05	3.86	5.86	7.05	7.70
NRV/NRVH 19	0.05	5.90	8.95	10.8	11.8
NRV/NRVH 22	0.05	9.11	13.8	16.7	18.2
NRV/NRVH 28	0.05	17.7	26.9	32.3	35.3
NRV/NRVH 35	0.05	31.1	47.2	56.8	62.0

R448A

Type	0.07	0.05	0.05	0.05	0.05
NRV/NRVH 6	0.07	0.50	0.81	0.99	1.10
NRV/NRVH 10	0.07	1.08	1.73	2.13	2.35
NRV/NRVH 12	0.05	1.57	2.51	3.09	3.40
NRV/NRVH 16	0.05	2.76	4.41	5.42	5.97
NRV/NRVH 19	0.05	4.22	6.74	8.28	9.12
NRV/NRVH 22	0.05	6.52	10.4	12.8	14.1
NRV/NRVH 28	0.05	12.7	20.2	24.8	27.4
NRV/NRVH 35	0.05	22.3	35.5	43.7	48.1

R449A

Type	0.07	0.05	0.05	0.05	0.05
NRV/NRVH 6	0.07	0.50	0.80	0.98	1.08
NRV/NRVH 10	0.07	1.07	1.71	2.11	2.32
NRV/NRVH 12	0.05	1.55	2.48	3.05	3.36
NRV/NRVH 16	0.05	2.72	4.35	5.35	5.90
NRV/NRVH 19	0.05	4.16	6.65	8.18	9.01
NRV/NRVH 22	0.05	6.43	10.3	12.6	13.9
NRV/NRVH 28	0.05	12.5	20.0	24.5	27.0
NRV/NRVH 35	0.05	22.0	35.1	43.1	47.5

¹⁾ Rated suction vapour capacities are based on:

- Suction superheat $sh = 0\text{ K}$
- Condensing temperature, $t_c = 30\text{ °C}$
- Subcooling $\Delta t_{sub} = 5\text{ K}$

The table values refer to the evaporator capacity

Hot gas capacity (kW)

Type	Hot gas capacity ¹⁾ at pressure drop across valve Δp [bar]			
	NRV			NRV/ NRVH
	0.05	0.07	0.14	0.3 ²⁾

R410A

Type	0.05	0.07	0.14	0.3 ²⁾
NRV/NRVH 6	–	1.7	2.4	3.5
NRV/NRVH 10	–	3.6	5.1	7.5
NRV/NRVH 12	5.3	6.2	8.8	12.8
NRV/NRVH 16	9.3	10.9	15.4	22.5
NRV/NRVH 19	14.1	16.7	23.6	34.4
NRV/NRVH 22	21.9	25.9	36.5	53.1
NRV/NRVH 28	42.4	50.2	70.8	103
NRV/NRVH 35	74.6	88.2	124	181

R448A

Type	0.05	0.07	0.14	0.3 ²⁾
NRV/NRVH 6	–	1.4	2.0	3.0
NRV/NRVH 10	–	3.1	4.4	6.4
NRV/NRVH 12	4.5	5.3	7.5	10.9
NRV/NRVH 16	7.9	9.3	13.1	19.1
NRV/NRVH 19	12.0	14.2	20.0	29.1
NRV/NRVH 22	18.6	22.0	31.0	45.0
NRV/NRVH 28	36.1	42.6	60.1	87.4
NRV/NRVH 35	63.4	74.9	106	154

R449A

Type	0.05	0.07	0.14	0.3 ²⁾
NRV/NRVH 6	–	1.4	2.0	2.9
NRV/NRVH 10	–	3.1	4.3	6.3
NRV/NRVH 12	4.4	5.2	7.4	10.7
NRV/NRVH 16	7.8	9.2	12.9	18.8
NRV/NRVH 19	11.9	14.0	19.8	28.7
NRV/NRVH 22	18.3	21.7	30.5	44.4
NRV/NRVH 28	35.6	42.0	59.3	86.1
NRV/NRVH 35	62.5	73.9	104	151

¹⁾ Rated hot gas capacities are based on:

- Evaporating temperature, $t_e = -10\text{ °C}$
- Condensing temperature, $t_c = 30\text{ °C}$
- Subcooling $\Delta t_{sub} = 5\text{ K}$
- Hot gas temperature, $t_h = 60\text{ °C}$ ahead of the valve
- Discharge temperature, $t_d = 80\text{ °C}$ after compressor

²⁾ Capacity for NR VH

The table values refer to the evaporator capacity

Correction factors

When selecting the evaporator capacity is to be multiplied by a correction factor depending on the liquid temperature t_l ahead of the valve/the evaporator. The corrected capacity can then be found from the table.

Correction factors for liquid temperature t_l

t_l [°C]	-10	0	10	15	20	25	30	35	40	45	50
R410A	0.72	0.78	0.85	0.90	0.95	1.00	1.06	1.14	1.22	1.32	1.45
R448A	0.72	0.78	0.85	0.90	0.95	1.00	1.06	1.13	1.22	1.31	1.43
R449A	0.71	0.77	0.85	0.89	0.94	1.00	1.06	1.14	1.22	1.32	1.44

Data sheet | Check valve, types NRV and NR VH

SI units

Capacity

Liquid capacity (kW)

Type	Liquid capacity ¹⁾ at pressure drop across valve Δp [bar]			
	NRV			NRV/ NR VH
	0.05	0.07	0.14	0.3 ²⁾

R450A

NRV/NRVH 6	-	6.60	9.30	13.7
NRV/NRVH 10	-	14.1	20.0	29.3
NRV/NRVH 12	20.4	24.2	34.2	50.0
NRV/NRVH 16	35.9	42.4	60.0	87.9
NRV/NRVH 19	54.8	64.8	91.7	134
NRV/NRVH 22	84.7	100	142	208
NRV/NRVH 28	164	195	275	403
NRV/NRVH 35	289	342	484	708

R452A

NRV/NRVH 6	-	5.30	7.50	11.0
NRV/NRVH 10	-	11.3	16.0	23.5
NRV/NRVH 12	16.4	19.4	27.4	40.1
NRV/NRVH 16	28.8	34.0	48.1	70.5
NRV/NRVH 19	44.0	52.0	73.6	107.7
NRV/NRVH 22	67.9	80.4	114	166.4
NRV/NRVH 28	132	156	221	323.0
NRV/NRVH 35	232	274	388	567.7

R513A

NRV/NRVH 6	-	6.30	9.00	13.1
NRV/NRVH 10	-	13.6	19.2	28.1
NRV/NRVH 12	19.6	23.2	32.8	48.0
NRV/NRVH 16	34.4	40.7	57.6	84.3
NRV/NRVH 19	52.6	62.2	88.0	129
NRV/NRVH 22	81.3	96.2	136	199
NRV/NRVH 28	158	187	264	387
NRV/NRVH 35	277	328	464	679

R1234ze

NRV/NRVH 6	-	6.40	9.00	13.2
NRV/NRVH 10	-	13.6	19.3	28.2
NRV/NRVH 12	19.7	23.3	32.9	48.2
NRV/NRVH 16	34.6	40.9	57.8	84.7
NRV/NRVH 19	52.8	62.5	88.4	129
NRV/NRVH 22	81.6	96.6	137	200
NRV/NRVH 28	158	188	265	388
NRV/NRVH 35	279	330	466	682

¹⁾ Rated liquid capacities are based on:

- Evaporating temperature, $t_e = -10\text{ }^\circ\text{C}$
- Condensing temperature, $t_c = 30\text{ }^\circ\text{C}$
- Subcooling $\Delta t_{sub} = 5\text{ K}$

²⁾ Capacity for NR VH

The table values refer to the evaporator capacity

Suction vapour capacity (kW)

Type	Pressure drop across valve Δp [bar]	Suction vapour capacity ¹⁾ at evaporating temperature t_e [$^\circ\text{C}$]			
		-30	-10	0	5

R450A

NRV/NRVH 6	0.07	0.33	0.57	0.72	0.80
NRV/NRVH 10	0.07	0.71	1.22	1.54	1.71
NRV/NRVH 12	0.05	1.04	1.77	2.23	2.48
NRV/NRVH 16	0.05	1.83	3.11	3.91	4.36
NRV/NRVH 19	0.05	2.80	4.75	5.98	6.66
NRV/NRVH 22	0.05	4.32	7.34	9.24	10.3
NRV/NRVH 28	0.05	8.39	14.3	17.9	20.0
NRV/NRVH 35	0.05	14.7	25.1	31.5	35.1

R452A

NRV/NRVH 6	0.07	0.44	0.72	0.89	0.98
NRV/NRVH 10	0.07	0.95	1.54	1.90	2.10
NRV/NRVH 12	0.05	1.38	2.23	2.75	3.04
NRV/NRVH 16	0.05	2.43	3.91	4.83	5.34
NRV/NRVH 19	0.05	3.71	5.98	7.39	8.17
NRV/NRVH 22	0.05	5.73	9.24	11.4	12.6
NRV/NRVH 28	0.05	11.1	17.9	22.2	24.5
NRV/NRVH 35	0.05	19.5	31.5	38.9	43.1

R513A

NRV/NRVH 6	0.07	0.36	0.61	0.77	0.86
NRV/NRVH 10	0.07	0.78	1.31	1.65	1.83
NRV/NRVH 12	0.05	1.14	1.91	2.39	2.66
NRV/NRVH 16	0.05	2.00	3.35	4.19	4.66
NRV/NRVH 19	0.05	3.06	5.12	6.41	7.13
NRV/NRVH 22	0.05	4.73	7.91	9.90	11.0
NRV/NRVH 28	0.05	9.18	15.4	19.2	21.4
NRV/NRVH 35	0.05	16.1	27.0	33.8	37.6

R1234ze

NRV/NRVH 6	0.07	0.29	0.52	0.66	0.73
NRV/NRVH 10	0.07	0.63	1.10	1.40	1.57
NRV/NRVH 12	0.05	0.93	1.61	2.04	2.28
NRV/NRVH 16	0.05	1.63	2.83	3.58	4.00
NRV/NRVH 19	0.05	2.49	4.32	5.47	6.12
NRV/NRVH 22	0.05	3.85	6.67	8.46	9.45
NRV/NRVH 28	0.05	7.47	13.0	16.4	18.35
NRV/NRVH 35	0.05	13.13	22.8	28.9	32.25

¹⁾ Rated suction vapour capacities are based on:

- Suction superheat $sh = 0\text{ K}$
- Condensing temperature, $t_c = 30\text{ }^\circ\text{C}$
- Subcooling $\Delta t_{sub} = 5\text{ K}$

The table values refer to the evaporator capacity

Hot gas capacity (kW)

Type	Hot gas capacity ¹⁾ at pressure drop across valve Δp [bar]			
	NRV			NRV/ NR VH
	0.05	0.07	0.14	0.3 ²⁾

R450A

NRV/NRVH 6	-	1.00	1.40	2.00
NRV/NRVH 10	-	2.20	3.00	4.40
NRV/NRVH 12	3.10	3.70	5.20	7.50
NRV/NRVH 16	5.50	6.50	9.10	13.1
NRV/NRVH 19	8.40	9.90	13.9	20.0
NRV/NRVH 22	12.9	15.3	21.4	30.9
NRV/NRVH 28	25.1	29.6	41.6	60.0
NRV/NRVH 35	44.1	52.1	73.2	105

R452A

NRV/NRVH 6	-	1.20	1.70	2.50
NRV/NRVH 10	-	2.60	3.70	5.40
NRV/NRVH 12	3.80	4.50	6.30	9.20
NRV/NRVH 16	6.70	7.90	11.1	16.2
NRV/NRVH 19	10.2	12.1	17.0	24.7
NRV/NRVH 22	15.8	18.6	26.3	38.2
NRV/NRVH 28	30.6	36.2	51.0	74.2
NRV/NRVH 35	53.8	63.6	89.6	130

R513A

NRV/NRVH 6	-	1.00	1.50	2.10
NRV/NRVH 10	-	2.20	3.20	4.60
NRV/NRVH 12	3.20	3.80	5.40	7.8
NRV/NRVH 16	5.70	6.70	9.50	13.7
NRV/NRVH 19	8.70	10.3	14.4	20.9
NRV/NRVH 22	13.4	15.9	22.3	32.2
NRV/NRVH 28	26.1	30.8	43.3	62.6
NRV/NRVH 35	45.8	54.1	76.1	110

R1234ze

NRV/NRVH 6	-	0.90	1.30	1.80
NRV/NRVH 10	-	2.00	2.70	3.90
NRV/NRVH 12	2.80	3.30	4.70	6.70
NRV/NRVH 16	5.00	5.90	8.20	11.8
NRV/NRVH 19	7.60	9.00	12.6	18.1
NRV/NRVH 22	11.7	13.9	19.5	28.0
NRV/NRVH 28	22.8	26.9	37.8	54.3
NRV/NRVH 35	40.1	47.3	66.4	95.4

¹⁾ Rated hot gas capacities are based on:

- Evaporating temperature, $t_e = -10\text{ }^\circ\text{C}$
- Condensing temperature, $t_c = 30\text{ }^\circ\text{C}$
- Subcooling $\Delta t_{sub} = 5\text{ K}$
- Hot gas temperature, $t_h = 60\text{ }^\circ\text{C}$ ahead of the valve
- Discharge temperature, $t_d = 80\text{ }^\circ\text{C}$ after compressor

²⁾ Capacity for NR VH

The table values refer to the evaporator capacity

Correction factors

When selecting the evaporator capacity is to be multiplied by a correction factor depending on the liquid temperature t_l ahead of the valve/the evaporator. The corrected capacity can then be found from the table.

Correction factors for liquid temperature t_l

t_l [$^\circ\text{C}$]	-10	0	10	15	20	25	30	35	40	45	50
R450A	0.72	0.79	0.86	0.90	0.95	1.00	1.06	1.12	1.20	1.28	1.38
R452A	0.67	0.74	0.83	0.88	0.93	1.00	1.08	1.17	1.27	1.40	1.57
R513A	0.71	0.77	0.85	0.89	0.94	1.00	1.06	1.14	1.22	1.32	1.44
R1234ze	0.72	0.78	0.86	0.90	0.95	1.00	1.06	1.12	1.20	1.29	1.39

Data sheet | Check valve, types NRV and NR VH

SI units

Capacity

Liquid capacity (kW)

Type	Liquid capacity ¹⁾ at pressure drop across valve Δp [bar]			
	NRV			NRV/ NRVH
	0.05	0.07	0.14	0.3 ²⁾

R32

NRV/NRVH 6	-	10.8	15.2	22.3
NRV/NRVH 10	-	23.1	32.7	47.8
NRV/NRVH 12	33.4	39.5	55.8	81.7
NRV/NRVH 16	58.6	69.3	98.0	144
NRV/NRVH 19	89.5	106	150	219
NRV/NRVH 22	139	164	231	339

R290

NRV/NRVH 6	-	8.60	12.1	17.7
NRV/NRVH 10	-	18.4	26.0	38.0
NRV/NRVH 12	26.5	31.4	44.3	64.9
NRV/NRVH 16	46.5	55.1	77.9	114
NRV/NRVH 19	71.1	84.1	119	174
NRV/NRVH 22	110	130	184	269

R600

NRV/NRVH 6	-	9.70	13.7	20.1
NRV/NRVH 10	-	20.8	29.4	43.0
NRV/NRVH 12	30.0	35.5	50.2	73.5
NRV/NRVH 16	52.7	62.3	88.1	129
NRV/NRVH 19	80.5	95.2	135	197
NRV/NRVH 22	124	147	208	305

R600a

NRV/NRVH 6	-	8.60	12.2	17.9
NRV/NRVH 10	-	18.5	26.1	38.3
NRV/NRVH 12	26.7	31.6	44.7	65.4
NRV/NRVH 16	46.9	55.5	78.4	115
NRV/NRVH 19	71.6	84.7	120	175
NRV/NRVH 22	111	131	185	271

¹⁾ Rated liquid capacities are based on:
 - Evaporating temperature, $t_e = -10^\circ\text{C}$
 - Condensing temperature, $t_c = 30^\circ\text{C}$
 - Subcooling $\Delta t_{\text{sub}} = 5\text{K}$

²⁾ Capacity for NR VH

The table values refer to the evaporator capacity

Suction vapour capacity (kW)

Type	Pressure drop across valve Δp [bar]	Suction vapour capacity ¹⁾ at evaporating temperature t_e [$^\circ\text{C}$]			
		-30	-10	0	5

R32

NRV/NRVH 6	0.07	0.92	1.38	1.64	1.78
NRV/NRVH 10	0.07	1.98	2.95	3.52	3.82
NRV/NRVH 12	0.05	2.87	4.27	5.08	5.52
NRV/NRVH 16	0.05	5.04	7.49	8.93	9.70
NRV/NRVH 19	0.05	7.70	11.4	13.6	14.8
NRV/NRVH 22	0.05	11.9	17.7	21.1	22.9

R290

NRV/NRVH 6	0.07	0.68	1.06	1.28	1.40
NRV/NRVH 10	0.07	1.47	2.26	2.74	3.01
NRV/NRVH 12	0.05	2.13	3.28	3.97	4.35
NRV/NRVH 16	0.05	3.75	5.76	6.97	7.64
NRV/NRVH 19	0.05	5.72	8.80	10.7	11.7
NRV/NRVH 22	0.05	8.85	13.6	16.5	18.0

R600

NRV/NRVH 6	0.07	0.28	0.52	0.67	0.76
NRV/NRVH 10	0.07	0.60	1.12	1.44	1.62
NRV/NRVH 12	0.05	0.92	1.65	2.11	2.36
NRV/NRVH 16	0.05	1.61	2.90	3.71	4.15
NRV/NRVH 19	0.05	2.46	4.43	5.66	6.34
NRV/NRVH 22	0.05	3.80	6.85	8.75	9.80

R600a

NRV/NRVH 6	0.07	0.35	0.61	0.77	0.86
NRV/NRVH 10	0.07	0.75	1.31	1.65	1.84
NRV/NRVH 12	0.05	1.12	1.91	2.40	2.68
NRV/NRVH 16	0.05	1.96	3.35	4.22	4.70
NRV/NRVH 19	0.05	2.99	5.12	6.44	7.18
NRV/NRVH 22	0.05	4.63	7.91	9.96	11.1

¹⁾ Rated suction vapour capacities are based on:
 - Suction superheat $sh = 0\text{K}$
 - Condensing temperature, $t_c = 30^\circ\text{C}$
 - Subcooling $\Delta t_{\text{sub}} = 5\text{K}$

The table values refer to the evaporator capacity

Hot gas capacity (kW)

Type	Hot gas capacity ¹⁾ at pressure drop across valve Δp [bar]			
	NRV			NRV/ NRVH
	0.05	0.07	0.14	0.3 ²⁾

R32

NRV/NRVH 6	-	2.20	3.10	4.50
NRV/NRVH 10	-	4.70	6.60	9.60
NRV/NRVH 12	6.80	8.00	11.3	16.4
NRV/NRVH 16	11.9	14.0	19.8	28.9
NRV/NRVH 19	18.1	21.4	30.3	44.1
NRV/NRVH 22	28.0	33.1	46.8	68.1

R290

NRV/NRVH 6	-	1.60	2.30	3.30
NRV/NRVH 10	-	3.50	4.90	7.20
NRV/NRVH 12	5.10	6.00	8.4	12.2
NRV/NRVH 16	8.90	10.5	14.8	21.5
NRV/NRVH 19	13.6	16.1	22.7	32.9
NRV/NRVH 22	21.0	24.9	35.0	50.8

R600

NRV/NRVH 6	-	1.00	1.30	1.90
NRV/NRVH 10	-	2.10	2.90	4.10
NRV/NRVH 12	3.00	3.50	4.90	7.00
NRV/NRVH 16	5.30	6.20	8.70	12.2
NRV/NRVH 19	8.1	9.5	13.2	18.7
NRV/NRVH 22	12.5	14.7	20.5	28.8

R600a

NRV/NRVH 6	-	1.10	1.50	2.10
NRV/NRVH 10	-	2.30	3.20	4.50
NRV/NRVH 12	3.30	3.90	5.40	7.70
NRV/NRVH 16	5.80	6.80	9.50	13.6
NRV/NRVH 19	8.80	10.4	14.6	20.8
NRV/NRVH 22	13.7	16.1	22.5	32.1

¹⁾ Rated hot gas capacities are based on:
 - Evaporating temperature, $t_e = -10^\circ\text{C}$
 - Condensing temperature, $t_c = 30^\circ\text{C}$
 - Subcooling $\Delta t_{\text{sub}} = 5\text{K}$
 - Hot gas temperature, $t_h = 60^\circ\text{C}$ ahead of the valve
 - Discharge temperature, $t_d = 80^\circ\text{C}$ after compressor

²⁾ Capacity for NR VH

The table values refer to the evaporator capacity

Correction factors

When selecting the evaporator capacity is to be multiplied by a correction factor depending on the liquid temperature t_l ahead of the valve/the evaporator. The corrected capacity can then be found from the table.

Correction factors for liquid temperature t_l

t_l [$^\circ\text{C}$]	-10	0	10	15	20	25	30	35	40	45	50
R32	0.76	0.82	0.88	0.92	0.96	1.00	1.05	1.11	1.17	1.24	1.33
R290	0.73	0.79	0.86	0.90	0.95	1.00	1.06	1.12	1.19	1.28	1.38
R600	0.77	0.82	0.88	0.92	0.96	1.00	1.05	1.10	1.16	1.22	1.29
R600a	0.75	0.80	0.87	0.91	0.95	1.00	1.05	1.11	1.18	1.25	1.33



Note: Only solder version, connection sizes from 6 s to 22 s are allowed for flammable refrigerant.

Capacity
Liquid capacity (kW)

Type	Liquid capacity ¹⁾ at pressure drop across valve Δp [bar]			
	NRV			NRV/ NRVH
	0.05	0.07	0.14	0.3 ²⁾

R1270

NRV/NRVH 6	–	8.90	12.6	18.4
NRV/NRVH 10	–	19.0	26.9	39.4
NRV/NRVH 12	27.5	32.5	46.0	67.3
NRV/NRVH 16	48.3	57.1	80.7	118
NRV/NRVH 19	73.7	87.2	123	181
NRV/NRVH 22	114	135	191	279

R452B

NRV/NRVH 6	–	9.0	12.7	18.6
NRV/NRVH 10	–	19.3	27.3	40.0
NRV/NRVH 12	27.9	33.0	46.6	68.3
NRV/NRVH 16	48.9	57.9	81.9	119.9
NRV/NRVH 19	74.8	88.5	125.1	183.1
NRV/NRVH 22	115.6	136.7	193.4	283.0

R454B

NRV/NRVH 6	–	8.80	12.4	18.2
NRV/NRVH 10	–	18.8	26.6	38.9
NRV/NRVH 12	27.1	32.1	45.4	66.5
NRV/NRVH 16	47.7	56.4	79.8	117
NRV/NRVH 19	72.8	86.2	122	178
NRV/NRVH 22	113	133	188	276

R1234yf

NRV/NRVH 6	–	5.30	7.50	10.9
NRV/NRVH 10	–	11.3	16.0	23.4
NRV/NRVH 12	16.3	19.3	27.3	40.0
NRV/NRVH 16	28.7	33.9	47.9	70.2
NRV/NRVH 19	43.8	51.8	73.3	107
NRV/NRVH 22	67.7	80.1	113	166

¹⁾ Rated liquid capacities are based on:
 - Evaporating temperature, $t_e = -10\text{ °C}$
 - Condensing temperature, $t_c = 30\text{ °C}$
 - Subcooling $\Delta t_{sub} = 5\text{ K}$

²⁾ Capacity for NR VH
 The table values refer to the evaporator capacity

Suction vapour capacity (kW)

Type	Pressure drop across valve Δp [bar]	Suction vapour capacity ¹⁾ at evaporating temperature t_e [°C]			
		-30	-10	0	5

R1270

NRV/NRVH 6	0.07	0.78	1.18	1.42	1.55
NRV/NRVH 10	0.07	1.68	2.54	3.05	3.33
NRV/NRVH 12	0.05	2.44	3.68	4.41	4.81
NRV/NRVH 16	0.05	4.28	6.45	7.75	8.45
NRV/NRVH 19	0.05	6.54	9.86	11.8	12.9
NRV/NRVH 22	0.05	10.1	15.2	18.3	20.0

R452B

NRV/NRVH 6	0.07	0.70	1.08	1.30	1.42
NRV/NRVH 10	0.07	1.51	2.31	2.79	3.05
NRV/NRVH 12	0.05	2.19	3.35	4.04	4.41
NRV/NRVH 16	0.05	3.85	5.88	7.09	7.75
NRV/NRVH 19	0.05	5.88	8.98	10.83	11.84
NRV/NRVH 22	0.05	9.09	13.88	16.74	18.29

R454B

NRV/NRVH 6	0.07	0.76	1.15	1.38	1.50
NRV/NRVH 10	0.07	1.62	2.46	2.95	3.22
NRV/NRVH 12	0.05	2.35	3.55	4.27	4.65
NRV/NRVH 16	0.05	4.13	6.24	7.49	8.17
NRV/NRVH 19	0.05	6.31	9.53	11.4	12.5
NRV/NRVH 22	0.05	9.75	14.7	17.7	19.3

R1234yf

NRV/NRVH 6	0.07	0.33	0.55	0.70	0.78
NRV/NRVH 10	0.07	0.70	1.19	1.49	1.66
NRV/NRVH 12	0.05	1.03	1.73	2.17	2.41
NRV/NRVH 16	0.05	1.81	3.03	3.80	4.23
NRV/NRVH 19	0.05	2.76	4.63	5.81	6.47
NRV/NRVH 22	0.05	4.27	7.16	8.98	10.0

¹⁾ Rated suction vapour capacities are based on:
 - Suction superheat $sh = 0\text{ K}$
 - Condensing temperature, $t_c = 30\text{ °C}$
 - Subcooling $\Delta t_{sub} = 5\text{ K}$
 The table values refer to the evaporator capacity

Hot gas capacity (kW)

Type	Hot gas capacity ¹⁾ at pressure drop across valve Δp [bar]			
	NRV			NRV/ NRVH
	0.05	0.07	0.14	0.3 ²⁾

R1270

NRV/NRVH 6	–	1.80	2.60	3.70
NRV/NRVH 10	–	3.90	5.50	8.00
NRV/NRVH 12	5.60	6.60	9.40	13.6
NRV/NRVH 16	9.90	11.7	16.5	23.9
NRV/NRVH 19	15.1	17.8	25.1	36.5
NRV/NRVH 22	23.3	27.6	38.9	56.4

R452B

NRV/NRVH 6	–	2.0	2.8	4.0
NRV/NRVH 10	–	4.2	5.9	8.6
NRV/NRVH 12	6.0	7.1	10.1	14.7
NRV/NRVH 16	10.6	12.6	17.7	25.8
NRV/NRVH 19	16.2	19.2	27.1	39.4
NRV/NRVH 22	25.1	29.6	41.8	60.9

R454B

NRV/NRVH 6	–	1.90	2.60	3.80
NRV/NRVH 10	–	4.00	5.60	8.20
NRV/NRVH 12	5.80	6.80	9.60	14.0
NRV/NRVH 16	10.1	11.9	16.9	24.5
NRV/NRVH 19	15.4	18.3	25.8	37.5
NRV/NRVH 22	23.9	28.2	39.8	58.0

R1234yf

NRV/NRVH 6	–	0.90	1.30	1.90
NRV/NRVH 10	–	2.00	2.80	4.00
NRV/NRVH 12	2.90	3.40	4.80	6.90
NRV/NRVH 16	5.00	5.90	8.30	12.0
NRV/NRVH 19	7.70	9.10	12.7	18.4
NRV/NRVH 22	11.9	14.0	19.7	28.5

¹⁾ Rated hot gas capacities are based on:
 - Evaporating temperature, $t_e = -10\text{ °C}$
 - Condensing temperature, $t_c = 30\text{ °C}$
 - Subcooling $\Delta t_{sub} = 5\text{ K}$
 - Hot gas temperature, $t_h = 60\text{ °C}$ ahead of the valve
 - Discharge temperature, $t_d = 80\text{ °C}$ after compressor
²⁾ Capacity for NR VH
 The table values refer to the evaporator capacity

Correction factors

When selecting the evaporator capacity is to be multiplied by a correction factor depending on the liquid temperature t_l ahead of the valve/the evaporator. The corrected capacity can then be found from the table.

Correction factors for liquid temperature t_l

t_l [°C]	-10	0	10	15	20	25	30	35	40	45	50
R1270	0.74	0.79	0.87	0.91	0.95	1.00	1.06	1.12	1.19	1.27	1.37
R452B	0.75	0.80	0.87	0.91	0.95	1.00	1.05	1.11	1.18	1.26	1.35
R454B	0.74	0.80	0.87	0.91	0.95	1.00	1.06	1.12	1.19	1.28	1.38
R1234yf	0.69	0.75	0.84	0.88	0.94	1.00	1.07	1.15	1.25	1.36	1.49



Note: Only solder version, connection sizes from 6 s to 22 s are allowed for flammable refrigerant.
 - For capacity calculation of other refrigerants, please contact Danfoss.

Data sheet | Check valve, types NRV and NR VH

Capacity

US units

Liquid capacity [TR]

Type	Liquid capacity ¹⁾ at pressure drop across valve Δp [psi]			
	NRV			NRV/ NRVH
	0.73	1.02	2.03	4.4 ²⁾

R22

Type	0.73	1.02	2.03	4.4 ²⁾
NRV/NRVH 6	0.70	2.20	3.10	4.60
NRV/NRVH 10	1.50	4.70	6.60	9.80
NRV/NRVH 12	6.80	8.00	11.3	16.7
NRV/NRVH 16	11.9	14.1	19.9	29.3
NRV/NRVH 19	18.2	21.5	30.4	44.7
NRV/NRVH 22	28.2	33.3	47.0	69.1
NRV/NRVH 28	54.7	64.6	91.2	134
NRV/NRVH 35	96.1	114	160	236

R134a

Type	0.73	1.02	2.03	4.4 ²⁾
NRV/NRVH 6	0.60	2.00	2.90	4.20
NRV/NRVH 10	1.30	4.30	6.10	9.00
NRV/NRVH 12	6.30	7.40	10.5	15.4
NRV/NRVH 16	11.0	13.0	18.4	27.1
NRV/NRVH 19	16.9	19.9	28.1	41.4
NRV/NRVH 22	26.1	30.8	43.4	64.0
NRV/NRVH 28	50.6	59.8	84.3	124
NRV/NRVH 35	88.9	105	148	218

R404A/R507

Type	0.73	1.02	2.03	4.4 ²⁾
NRV/NRVH 6	0.50	1.50	2.10	3.10
NRV/NRVH 10	1.00	3.20	4.50	6.60
NRV/NRVH 12	4.60	5.40	7.70	11.3
NRV/NRVH 16	8.10	9.50	13.5	19.8
NRV/NRVH 19	12.3	14.6	20.6	30.3
NRV/NRVH 22	19.1	22.5	31.8	46.8
NRV/NRVH 28	37.0	43.8	61.7	90.9
NRV/NRVH 35	65.1	76.9	109	160

¹⁾ Rated liquid capacities are based on:

- Evaporating temperature, $t_e = 14^\circ\text{F}$
- Condensing temperature, $t_c = 86^\circ\text{F}$
- Subcooling $\Delta t_{\text{sub}} = 9^\circ\text{F}$

²⁾ Capacity for NR VH

The table values refer to the evaporator capacity

Suction vapour capacity [TR]

Type	Pressure drop across valve Δp [psi]	Suction vapour capacity ¹⁾ at evaporating temperature t_e [°F]			
		-22	14	32	41

R22

Type	0.73	1.02	2.03	4.4 ²⁾	
NRV/NRVH 6	1.02	0.16	0.25	0.30	0.32
NRV/NRVH 10	1.02	0.34	0.53	0.64	0.69
NRV/NRVH 12	0.73	0.50	0.76	0.92	1.01
NRV/NRVH 16	0.73	0.87	1.34	1.62	1.77
NRV/NRVH 19	0.73	1.34	2.05	2.47	2.70
NRV/NRVH 22	0.73	2.06	3.16	3.82	4.17
NRV/NRVH 28	0.73	4.01	6.14	7.41	8.10
NRV/NRVH 35	0.73	7.04	10.8	13.0	14.2

R134a

Type	0.73	1.02	2.03	4.4 ²⁾	
NRV/NRVH 6	1.02	0.11	0.18	0.23	0.25
NRV/NRVH 10	1.02	0.23	0.39	0.49	0.54
NRV/NRVH 12	0.73	0.34	0.56	0.71	0.78
NRV/NRVH 16	0.73	0.59	0.99	1.24	1.38
NRV/NRVH 19	0.73	0.90	1.51	1.89	2.10
NRV/NRVH 22	0.73	1.40	2.34	2.93	3.25
NRV/NRVH 28	0.73	2.71	4.54	5.68	6.31
NRV/NRVH 35	0.73	4.76	7.98	9.98	11.1

R404A/R507

Type	0.73	1.02	2.03	4.4 ²⁾	
NRV/NRVH 6	1.02	0.13	0.21	0.26	0.29
NRV/NRVH 10	1.02	0.29	0.46	0.56	0.62
NRV/NRVH 12	0.73	0.42	0.66	0.82	0.90
NRV/NRVH 16	0.73	0.73	1.16	1.43	1.58
NRV/NRVH 19	0.73	1.12	1.78	2.19	2.41
NRV/NRVH 22	0.73	1.72	2.75	3.38	3.73
NRV/NRVH 28	0.73	3.35	5.34	6.57	7.24
NRV/NRVH 35	0.73	5.88	9.38	11.5	12.7

¹⁾ Rated suction vapour capacities are based on:

- Suction superheat $sh = 0^\circ\text{F}$
- Condensing temperature, $t_c = 86^\circ\text{F}$
- Subcooling $\Delta t_{\text{sub}} = 9^\circ\text{F}$

The table values refer to the evaporator capacity

Hot gas capacity [TR]

Type	Hot gas capacity ¹⁾ at pressure drop across valve Δp [psi]			
	NRV			NRV/ NRVH
	0.73	1.02	2.03	4.4 ²⁾

R22

Type	0.73	1.02	2.03	4.4 ²⁾
NRV/NRVH 6	0.10	0.30	0.50	0.70
NRV/NRVH 10	0.20	0.70	1.00	1.50
NRV/NRVH 12	1.10	1.20	1.70	2.60
NRV/NRVH 16	1.80	2.20	3.10	4.50
NRV/NRVH 19	2.80	3.30	4.70	6.80
NRV/NRVH 22	4.40	5.20	7.30	10.6
NRV/NRVH 28	8.50	10.0	14.1	20.5
NRV/NRVH 35	14.9	17.6	24.7	36.1

R134a

Type	0.73	1.02	2.03	4.4 ²⁾
NRV/NRVH 6	0.10	0.30	0.40	0.60
NRV/NRVH 10	0.20	0.60	0.80	1.20
NRV/NRVH 12	0.80	1.00	1.40	2.00
NRV/NRVH 16	1.50	1.70	2.40	3.50
NRV/NRVH 19	2.30	2.70	3.70	5.40
NRV/NRVH 22	3.50	4.10	5.80	8.40
NRV/NRVH 28	6.80	8.00	11.2	16.3
NRV/NRVH 35	11.9	14.0	19.7	28.6

R404A/R507

Type	0.73	1.02	2.03	4.4 ²⁾
NRV/NRVH 6	0.10	0.30	0.40	0.60
NRV/NRVH 10	0.20	0.60	0.90	1.30
NRV/NRVH 12	0.90	1.10	1.50	2.20
NRV/NRVH 16	1.60	1.90	2.60	3.80
NRV/NRVH 19	2.40	2.80	4.00	5.80
NRV/NRVH 22	3.70	4.40	6.20	9.00
NRV/NRVH 28	7.20	8.50	12.0	17.5
NRV/NRVH 35	12.7	14.9	21.0	30.7

¹⁾ Rated hot gas capacities are based on:

- Evaporating temperature, $t_e = 14^\circ\text{F}$
- Condensing temperature, $t_c = 86^\circ\text{F}$
- Subcooling $\Delta t_{\text{sub}} = 9^\circ\text{F}$
- Hot gas temperature, $t_h = 140^\circ\text{F}$ ahead of the valve
- Discharge temperature, $t_d = 176^\circ\text{F}$ after compressor

²⁾ Capacity for NR VH

The table values refer to the evaporator capacity

Correction factors

When selecting the evaporator capacity is to be multiplied by a correction factor depending on the liquid temperature t_l ahead of the valve/the evaporator. The corrected capacity can then be found from the table.

Correction factors for liquid temperature t_l

t_l [°F]	14	32	50	59	68	77	86	95	104	113	122
R22	0.77	0.82	0.88	0.92	0.96	1.00	1.05	1.10	1.16	1.22	1.30
R134a	0.73	0.79	0.86	0.90	0.95	1.00	1.06	1.12	1.19	1.28	1.37
R404A/R507	0.67	0.74	0.82	0.87	0.93	1.00	1.08	1.17	1.29	1.43	1.61

Data sheet | Check valve, types NRV and NR VH

Capacity

US units

Liquid capacity [TR]

Type	Liquid capacity ¹⁾ at pressure drop across valve Δp [psi]			
	NRV			NRV/ NRVH
	0.73	1.02	2.03	4.4 ²⁾

R407A

Type	0.73	1.02	2.03	4.4
NRV/NRVH 6	0.60	1.90	2.70	4.00
NRV/NRVH 10	1.30	4.20	5.90	8.60
NRV/NRVH 12	6.00	7.10	10.0	14.7
NRV/NRVH 16	10.5	12.5	17.6	25.9
NRV/NRVH 19	16.1	19.0	26.9	39.5
NRV/NRVH 22	24.9	29.4	41.5	61.1
NRV/NRVH 28	48.3	57.1	80.6	119
NRV/NRVH 35	84.9	100	142	209

R407C

Type	0.73	1.02	2.03	4.4
NRV/NRVH 6	0.60	2.10	3.00	4.30
NRV/NRVH 10	1.40	4.50	6.30	9.30
NRV/NRVH 12	6.50	7.70	10.8	15.9
NRV/NRVH 16	11.4	13.4	19.0	27.9
NRV/NRVH 19	17.4	20.5	29.0	42.7
NRV/NRVH 22	26.9	31.8	44.8	65.9
NRV/NRVH 28	52.1	61.6	86.9	128
NRV/NRVH 35	91.6	108	153	225

R407F

Type	0.73	1.02	2.03	4.4
NRV/NRVH 6	0.70	2.10	3.00	4.40
NRV/NRVH 10	1.40	4.60	6.50	9.50
NRV/NRVH 12	6.60	7.80	11.1	16.3
NRV/NRVH 16	11.6	13.8	19.4	28.6
NRV/NRVH 19	17.8	21.0	29.7	43.7
NRV/NRVH 22	27.5	32.5	45.8	67.5
NRV/NRVH 28	53.3	63.1	89.0	131
NRV/NRVH 35	93.8	111	156	230

¹⁾ Rated liquid capacities are based on:

- Evaporating temperature, $t_e = 14^\circ\text{F}$
- Condensing temperature, $t_c = 86^\circ\text{F}$
- Subcooling $\Delta t_{\text{sub}} = 9^\circ\text{F}$

²⁾ Capacity for NR VH

The table values refer to the evaporator capacity

Suction vapour capacity [TR]

Type	Pressure drop across valve Δp [psi]	Suction vapour capacity ¹⁾ at evaporating temperature t_e [°F]			
		-22	14	32	41

R407A

Type	0.73	1.02	2.03	4.4
NRV/NRVH 6	1.02	0.14	0.22	0.28
NRV/NRVH 10	1.02	0.30	0.48	0.59
NRV/NRVH 12	0.73	0.43	0.70	0.86
NRV/NRVH 16	0.73	0.76	1.23	1.51
NRV/NRVH 19	0.73	1.16	1.87	2.31
NRV/NRVH 22	0.73	1.80	2.90	3.57
NRV/NRVH 28	0.73	3.49	5.62	6.93
NRV/NRVH 35	0.73	6.13	9.88	12.2

R407C

Type	0.73	1.02	2.03	4.4
NRV/NRVH 6	1.02	0.14	0.23	0.28
NRV/NRVH 10	1.02	0.30	0.49	0.66
NRV/NRVH 12	0.73	0.44	0.71	0.96
NRV/NRVH 16	0.73	0.77	1.24	1.69
NRV/NRVH 19	0.73	1.18	1.90	2.58
NRV/NRVH 22	0.73	1.82	2.93	3.99
NRV/NRVH 28	0.73	3.53	5.69	7.75
NRV/NRVH 35	0.73	6.21	10.0	13.6

R407F

Type	0.73	1.02	2.03	4.4
NRV/NRVH 6	1.02	0.15	0.25	0.30
NRV/NRVH 10	1.02	0.33	0.53	0.71
NRV/NRVH 12	0.73	0.48	0.77	1.03
NRV/NRVH 16	0.73	0.85	1.35	1.81
NRV/NRVH 19	0.73	1.30	2.06	2.77
NRV/NRVH 22	0.73	2.00	3.18	4.28
NRV/NRVH 28	0.73	3.89	6.17	8.30
NRV/NRVH 35	0.73	6.83	10.8	14.6

¹⁾ Rated suction vapour capacities are based on:

- Suction superheat $sh = 0^\circ\text{F}$
- Condensing temperature, $t_c = 86^\circ\text{F}$
- Subcooling $\Delta t_{\text{sub}} = 9^\circ\text{F}$

The table values refer to the evaporator capacity

Hot gas capacity [TR]

Type	Hot gas capacity ¹⁾ at pressure drop across valve Δp [psi]			
	NRV			NRV/ NRVH
	0.73	1.02	2.03	4.4 ²⁾

R407A

Type	0.73	1.02	2.03	4.4
NRV/NRVH 6	0.10	0.30	0.50	0.70
NRV/NRVH 10	0.20	0.70	1.00	1.50
NRV/NRVH 12	1.10	1.30	1.80	2.60
NRV/NRVH 16	1.90	2.20	3.10	4.50
NRV/NRVH 19	2.90	3.40	4.70	6.90
NRV/NRVH 22	4.40	5.20	7.30	10.7
NRV/NRVH 28	8.60	10.1	14.2	20.8
NRV/NRVH 35	15.1	17.8	25.0	36.6

R407C

Type	0.73	1.02	2.03	4.4
NRV/NRVH 6	0.10	0.40	0.50	0.70
NRV/NRVH 10	0.20	0.80	1.10	1.60
NRV/NRVH 12	1.10	1.30	1.80	2.70
NRV/NRVH 16	1.90	2.30	3.20	4.70
NRV/NRVH 19	2.90	3.50	4.90	7.20
NRV/NRVH 22	4.60	5.40	7.60	11.1
NRV/NRVH 28	8.80	10.5	14.7	21.5
NRV/NRVH 35	15.6	18.4	25.8	37.7

R407F

Type	0.73	1.02	2.03	4.4
NRV/NRVH 6	0.10	0.40	0.50	0.80
NRV/NRVH 10	0.20	0.80	1.10	1.70
NRV/NRVH 12	1.20	1.40	1.90	2.80
NRV/NRVH 16	2.00	2.40	3.40	5.00
NRV/NRVH 19	3.10	3.70	5.20	7.60
NRV/NRVH 22	4.80	5.70	8.00	11.7
NRV/NRVH 28	9.30	11.0	15.5	22.7
NRV/NRVH 35	16.4	19.4	27.3	39.9

¹⁾ Rated hot gas capacities are based on:

- Evaporating temperature, $t_e = 14^\circ\text{F}$
- Condensing temperature, $t_c = 86^\circ\text{F}$
- Subcooling $\Delta t_{\text{sub}} = 9^\circ\text{F}$
- Hot gas temperature, $t_h = 140^\circ\text{F}$ ahead of the valve
- Discharge temperature, $t_d = 176^\circ\text{F}$ after compressor

²⁾ Capacity for NR VH

The table values refer to the evaporator capacity

Correction factors

When selecting the evaporator capacity is to be multiplied by a correction factor depending on the liquid temperature t_l ahead of the valve/the evaporator. The corrected capacity can then be found from the table.

Correction factors for liquid temperature t_l

t_l [°F]	14	32	50	59	68	77	86	95	104	113	122
R407A	0.71	0.78	0.85	0.90	0.94	1.00	1.06	1.13	1.22	1.32	1.43
R407C	0.73	0.79	0.86	0.90	0.95	1.00	1.06	1.13	1.20	1.29	1.40
R407F	0.73	0.79	0.86	0.90	0.95	1.00	1.06	1.12	1.20	1.29	1.39

Data sheet | Check valve, types NRV and NR VH

Capacity

US units

Liquid capacity [TR]

Type	Liquid capacity ¹⁾ at pressure drop across valve Δp [psi]			
	NRV			NRV/ NRVH
	0.73	1.02	2.03	4.4 ²⁾

R410A

Type	0.73	1.02	2.03	4.4
NRV/NRVH 6	0.70	2.10	3.00	4.50
NRV/NRVH 10	1.40	4.60	6.50	9.60
NRV/NRVH 12	6.70	7.90	11.1	16.3
NRV/NRVH 16	11.7	13.8	19.5	28.7
NRV/NRVH 19	17.9	21.1	29.8	43.9
NRV/NRVH 22	27.6	32.6	46.0	67.8
NRV/NRVH 28	53.6	63.3	89.4	132
NRV/NRVH 35	94.2	111	157	231

R448A

Type	0.73	1.02	2.03	4.4
NRV/NRVH 6	0.60	1.90	2.70	4.00
NRV/NRVH 10	1.30	4.20	5.90	8.70
NRV/NRVH 12	6.00	7.10	10.1	14.8
NRV/NRVH 16	10.6	12.5	17.7	26.0
NRV/NRVH 19	16.2	19.1	27.0	39.7
NRV/NRVH 22	25.0	29.6	41.7	61.4
NRV/NRVH 28	48.6	57.4	81.0	119
NRV/NRVH 35	85.4	101	142	210

R449A

Type	0.73	1.02	2.03	4.00
NRV/NRVH 6	0.60	1.90	2.70	4.00
NRV/NRVH 10	1.30	4.10	5.80	8.50
NRV/NRVH 12	5.90	7.00	9.90	14.5
NRV/NRVH 16	10.4	12.3	17.3	25.5
NRV/NRVH 19	15.9	18.8	26.5	39.0
NRV/NRVH 22	24.6	29.0	41.0	60.3
NRV/NRVH 28	47.7	56.4	79.5	117
NRV/NRVH 35	83.8	99.1	140	206

¹⁾ Rated liquid capacities are based on:

- Evaporating temperature, $t_e = 14^\circ\text{F}$
- Condensing temperature, $t_c = 86^\circ\text{F}$
- Subcooling $\Delta t_{\text{sub}} = 9^\circ\text{F}$

²⁾ Capacity for NR VH

The table values refer to the evaporator capacity

Suction vapour capacity [TR]

Type	Pressure drop across valve Δp [psi]	Suction vapour capacity ¹⁾ at evaporating temperature t_e [°F]			
		-22	14	32	41

R410A

Type	1.02	0.20	0.31	0.37	0.40
NRV/NRVH 6	1.02	0.20	0.31	0.37	0.40
NRV/NRVH 10	1.02	0.43	0.66	0.79	0.86
NRV/NRVH 12	0.73	0.63	0.95	1.15	1.25
NRV/NRVH 16	0.73	1.10	1.67	2.01	2.20
NRV/NRVH 19	0.73	1.68	2.55	3.07	3.35
NRV/NRVH 22	0.73	2.60	3.95	4.75	5.18
NRV/NRVH 28	0.73	5.05	7.66	9.22	10.1
NRV/NRVH 35	0.73	8.87	13.5	16.2	17.7

R448A

Type	1.02	0.14	0.23	0.28	0.31
NRV/NRVH 6	1.02	0.14	0.23	0.28	0.31
NRV/NRVH 10	1.02	0.31	0.49	0.61	0.67
NRV/NRVH 12	0.73	0.45	0.72	0.88	0.97
NRV/NRVH 16	0.73	0.79	1.26	1.55	1.70
NRV/NRVH 19	0.73	1.20	1.92	2.36	2.60
NRV/NRVH 22	0.73	1.86	2.97	3.65	4.02
NRV/NRVH 28	0.73	3.61	5.77	7.08	7.81
NRV/NRVH 35	0.73	6.35	10.1	12.5	13.7

R449A

Type	1.02	0.14	0.23	0.28	0.31
NRV/NRVH 6	1.02	0.14	0.23	0.28	0.31
NRV/NRVH 10	1.02	0.30	0.49	0.60	0.66
NRV/NRVH 12	0.73	0.44	0.71	0.87	0.96
NRV/NRVH 16	0.73	0.78	1.24	1.53	1.68
NRV/NRVH 19	0.73	1.19	1.90	2.33	2.57
NRV/NRVH 22	0.73	1.84	2.93	3.60	3.97
NRV/NRVH 28	0.73	3.56	5.69	7.00	7.71
NRV/NRVH 35	0.73	6.26	10.0	12.3	13.6

¹⁾ Rated suction vapour capacities are based on:

- Suction superheat $sh = 0^\circ\text{F}$
- Condensing temperature, $t_c = 86^\circ\text{F}$
- Subcooling $\Delta t_{\text{sub}} = 9^\circ\text{F}$

The table values refer to the evaporator capacity

Hot gas capacity [TR]

Type	Hot gas capacity ¹⁾ at pressure drop across valve Δp [psi]			
	NRV			NRV/ NRVH
	0.73	1.02	2.03	4.4 ²⁾

R410A

Type	0.73	1.02	2.03	4.4
NRV/NRVH 6	0.10	0.40	0.60	0.80
NRV/NRVH 10	0.30	0.90	1.20	1.80
NRV/NRVH 12	1.30	1.50	2.10	3.10
NRV/NRVH 16	2.20	2.60	3.70	5.40
NRV/NRVH 19	3.40	4.00	5.70	8.30
NRV/NRVH 22	5.30	6.20	8.80	12.8
NRV/NRVH 28	10.2	12.1	17.0	24.9
NRV/NRVH 35	18.0	21.2	29.9	43.8

R448A

Type	0.73	1.02	2.03	4.4
NRV/NRVH 6	0.10	0.30	0.50	0.70
NRV/NRVH 10	0.20	0.70	1.10	1.50
NRV/NRVH 12	1.10	1.30	1.80	2.60
NRV/NRVH 16	1.90	2.20	3.20	4.60
NRV/NRVH 19	2.90	3.40	4.80	7.10
NRV/NRVH 22	4.50	5.30	7.50	10.9
NRV/NRVH 28	8.70	10.3	14.5	21.2
NRV/NRVH 35	15.3	18.1	25.5	37.2

R449A

Type	0.73	1.02	2.03	4.4
NRV/NRVH 6	0.10	0.30	0.50	0.70
NRV/NRVH 10	0.20	0.70	1.00	1.50
NRV/NRVH 12	1.10	1.30	1.80	2.60
NRV/NRVH 16	1.90	2.20	3.10	4.60
NRV/NRVH 19	2.90	3.40	4.80	7.00
NRV/NRVH 22	4.40	5.20	7.40	10.7
NRV/NRVH 28	8.60	10.1	14.3	20.9
NRV/NRVH 35	15.1	17.8	25.1	36.7

¹⁾ Rated hot gas capacities are based on:

- Evaporating temperature, $t_e = 14^\circ\text{F}$
- Condensing temperature, $t_c = 86^\circ\text{F}$
- Subcooling $\Delta t_{\text{sub}} = 9^\circ\text{F}$
- Hot gas temperature, $t_h = 140^\circ\text{F}$ ahead of the valve
- Discharge temperature, $t_d = 176^\circ\text{F}$ after compressor

²⁾ Capacity for NR VH

The table values refer to the evaporator capacity

Correction factors

When selecting the evaporator capacity is to be multiplied by a correction factor depending on the liquid temperature t_l ahead of the valve/the evaporator. The corrected capacity can then be found from the table.

Correction factors for liquid temperature t_l

t_l [°F]	14	32	50	59	68	77	86	95	104	113	122
R410A	0.72	0.78	0.85	0.90	0.95	1.00	1.06	1.14	1.22	1.32	1.45
R448A	0.72	0.78	0.85	0.90	0.95	1.00	1.06	1.13	1.22	1.31	1.43
R449A	0.71	0.77	0.85	0.89	0.94	1.00	1.06	1.14	1.22	1.32	1.44

Data sheet | Check valve, types NRV and NR VH

Capacity

US units

Liquid capacity [TR]

Type	Liquid capacity ¹⁾ at pressure drop across valve Δp [psi]			
	NRV			NRV/ NR VH
	0.73	1.02	2.03	4.4 ²⁾

R450A

Type	0.73	1.02	2.03	4.4 ²⁾
NRV/NRVH 6	0.60	1.90	2.70	3.90
NRV/NRVH 10	1.20	4.00	5.70	8.40
NRV/NRVH 12	5.80	6.90	9.70	14.3
NRV/NRVH 16	10.2	12.1	17.1	25.1
NRV/NRVH 19	15.6	18.5	26.1	38.4
NRV/NRVH 22	24.2	28.6	40.3	59.3
NRV/NRVH 28	46.9	55.4	78.2	115
NRV/NRVH 35	82.4	97.4	138	202

R452A

Type	0.73	1.02	2.03	4.4 ²⁾
NRV/NRVH 6	0.50	1.50	2.10	3.10
NRV/NRVH 10	1.00	3.20	4.60	6.70
NRV/NRVH 12	4.70	5.50	7.80	11.5
NRV/NRVH 16	8.20	9.70	13.7	20.2
NRV/NRVH 19	12.5	14.8	20.9	30.8
NRV/NRVH 22	19.4	22.9	32.3	47.6
NRV/NRVH 28	37.6	44.5	62.7	92.4
NRV/NRVH 35	66.1	78.2	110	162

R513A

Type	0.73	1.02	2.03	4.4 ²⁾
NRV/NRVH 6	0.60	1.80	2.50	3.80
NRV/NRVH 10	1.20	3.90	5.50	8.00
NRV/NRVH 12	5.60	6.60	9.30	13.7
NRV/NRVH 16	9.80	11.6	16.4	24.1
NRV/NRVH 19	15.0	17.7	25.0	36.8
NRV/NRVH 22	23.2	27.4	38.7	56.9
NRV/NRVH 28	45.0	53.2	75.1	111
NRV/NRVH 35	79.1	93.5	132	194

R1234ze

Type	0.73	1.02	2.03	4.4 ²⁾
NRV/NRVH 6	0.60	1.80	2.60	3.80
NRV/NRVH 10	1.20	3.90	5.50	8.10
NRV/NRVH 12	5.60	6.60	9.40	13.8
NRV/NRVH 16	9.90	11.7	16.4	24.2
NRV/NRVH 19	15.1	17.8	25.1	37.0
NRV/NRVH 22	23.3	27.5	38.8	57.2
NRV/NRVH 28	45.2	53.4	75.4	111
NRV/NRVH 35	79.4	93.9	133	195

¹⁾ Rated liquid capacities are based on:

- Evaporating temperature, $t_e = 14\text{ }^\circ\text{F}$
- Condensing temperature, $t_c = 86\text{ }^\circ\text{F}$
- Subcooling $\Delta t_{sub} = 9\text{ }^\circ\text{F}$

²⁾ Capacity for NR VH

The table values refer to the evaporator capacity

Suction vapour capacity [TR]

Type	Pressure drop across valve Δp [psi]	Suction vapour capacity ¹⁾ at evaporating temperature t_e [$^\circ\text{F}$]			
		-22	14	32	41

R450A

Type	-22	14	32	41	
NRV/NRVH 6	1.02	0.09	0.16	0.20	0.23
NRV/NRVH 10	1.02	0.20	0.35	0.44	0.49
NRV/NRVH 12	0.73	0.30	0.51	0.64	0.71
NRV/NRVH 16	0.73	0.52	0.89	1.12	1.24
NRV/NRVH 19	0.73	0.80	1.36	1.71	1.90
NRV/NRVH 22	0.73	1.23	2.10	2.64	2.94
NRV/NRVH 28	0.73	2.39	4.07	5.12	5.70
NRV/NRVH 35	0.73	4.21	7.15	8.99	10.0

R452A

Type	-22	14	32	41	
NRV/NRVH 6	1.02	0.13	0.20	0.25	0.28
NRV/NRVH 10	1.02	0.27	0.44	0.54	0.60
NRV/NRVH 12	0.73	0.39	0.64	0.79	0.87
NRV/NRVH 16	0.73	0.69	1.12	1.38	1.52
NRV/NRVH 19	0.73	1.06	1.71	2.11	2.33
NRV/NRVH 22	0.73	1.63	2.64	3.26	3.60
NRV/NRVH 28	0.73	3.17	5.12	6.32	6.99
NRV/NRVH 35	0.73	5.57	8.99	11.1	12.3

R513A

Type	-22	14	32	41	
NRV/NRVH 6	1.02	0.10	0.17	0.22	0.24
NRV/NRVH 10	1.02	0.22	0.37	0.47	0.52
NRV/NRVH 12	0.73	0.33	0.54	0.68	0.76
NRV/NRVH 16	0.73	0.57	0.96	1.20	1.33
NRV/NRVH 19	0.73	0.87	1.46	1.83	2.03
NRV/NRVH 22	0.73	1.35	2.26	2.83	3.14
NRV/NRVH 28	0.73	2.62	4.38	5.48	6.10
NRV/NRVH 35	0.73	4.60	7.70	9.64	10.7

R1234ze

Type	-22	14	32	41	
NRV/NRVH 6	1.02	0.08	0.15	0.19	0.21
NRV/NRVH 10	1.02	0.18	0.31	0.40	0.45
NRV/NRVH 12	0.73	0.26	0.46	0.58	0.65
NRV/NRVH 16	0.73	0.46	0.81	1.02	1.14
NRV/NRVH 19	0.73	0.71	1.23	1.56	1.75
NRV/NRVH 22	0.73	1.10	1.90	2.41	2.70
NRV/NRVH 28	0.73	2.13	3.69	4.68	5.24
NRV/NRVH 35	0.73	3.74	6.49	8.23	9.20

¹⁾ Rated suction vapour capacities are based on:

- Suction superheat $sh = 0\text{ }^\circ\text{F}$
- Condensing temperature, $t_c = 86\text{ }^\circ\text{F}$
- Subcooling $\Delta t_{sub} = 9\text{ }^\circ\text{F}$

The table values refer to the evaporator capacity

Hot gas capacity [TR]

Type	Hot gas capacity ¹⁾ at pressure drop across valve Δp [psi]			
	NRV			NRV/ NR VH
	0.73	1.02	2.03	4.4 ²⁾

R450A

Type	0.73	1.02	2.03	4.4 ²⁾
NRV/NRVH 6	0.10	0.20	0.30	0.50
NRV/NRVH 10	0.20	0.50	0.70	1.10
NRV/NRVH 12	0.80	0.90	1.30	1.80
NRV/NRVH 16	1.30	1.60	2.20	3.20
NRV/NRVH 19	2.10	2.40	3.40	4.90
NRV/NRVH 22	3.20	3.80	5.30	7.60
NRV/NRVH 28	6.20	7.30	10.2	14.8
NRV/NRVH 35	10.9	12.8	17.9	26.0

R452A

Type	0.73	1.02	2.03	4.4 ²⁾
NRV/NRVH 6	0.10	0.30	0.40	0.60
NRV/NRVH 10	0.20	0.60	0.90	1.30
NRV/NRVH 12	0.90	1.10	1.50	2.20
NRV/NRVH 16	1.60	1.90	2.70	3.90
NRV/NRVH 19	2.50	2.90	4.10	6.00
NRV/NRVH 22	3.80	4.50	6.30	9.20
NRV/NRVH 28	7.40	8.70	12.3	17.9
NRV/NRVH 35	13.0	15.3	21.6	31.5

R513A

Type	0.73	1.02	2.03	4.4 ²⁾
NRV/NRVH 6	0.10	0.30	0.40	0.50
NRV/NRVH 10	0.20	0.50	0.80	1.10
NRV/NRVH 12	0.80	0.90	1.30	1.90
NRV/NRVH 16	1.40	1.60	2.30	3.40
NRV/NRVH 19	2.10	2.50	3.50	5.10
NRV/NRVH 22	3.30	3.90	5.50	7.90
NRV/NRVH 28	6.40	7.60	10.6	15.4
NRV/NRVH 35	11.3	13.3	18.6	27.1

R1234ze

Type	0.73	1.02	2.03	4.4 ²⁾
NRV/NRVH 6	0.10	0.20	0.30	0.50
NRV/NRVH 10	0.10	0.50	0.70	1.00
NRV/NRVH 12	0.70	0.80	1.20	1.70
NRV/NRVH 16	1.20	1.40	2.00	2.90
NRV/NRVH 19	1.90	2.20	3.10	4.50
NRV/NRVH 22	2.90	3.40	4.80	6.90
NRV/NRVH 28	5.60	6.60	9.30	13.4
NRV/NRVH 35	9.90	11.7	16.3	23.6

¹⁾ Rated hot gas capacities are based on:

- Evaporating temperature, $t_e = 14\text{ }^\circ\text{F}$
- Condensing temperature, $t_c = 86\text{ }^\circ\text{F}$
- Subcooling $\Delta t_{sub} = 9\text{ }^\circ\text{F}$
- Hot gas temperature, $t_h = 140\text{ }^\circ\text{F}$ ahead of the valve
- Discharge temperature, $t_d = 176\text{ }^\circ\text{F}$ after compressor

²⁾ Capacity for NR VH

The table values refer to the evaporator capacity

Correction factors

When selecting the evaporator capacity is to be multiplied by a correction factor depending on the liquid temperature t_l ahead of the valve/the evaporator. The corrected capacity can then be found from the table.

Correction factors for liquid temperature t_l

t_l [$^\circ\text{F}$]	14	32	50	59	68	77	86	95	104	113	122
R450A	0.72	0.79	0.86	0.90	0.95	1.00	1.06	1.12	1.20	1.28	1.38
R452A	0.67	0.74	0.83	0.88	0.93	1.00	1.08	1.17	1.27	1.40	1.57
R513A	0.71	0.77	0.85	0.89	0.94	1.00	1.06	1.14	1.22	1.32	1.44
R1234ze	0.72	0.78	0.86	0.90	0.95	1.00	1.06	1.12	1.20	1.29	1.39

Data sheet | Check valve, types NRV and NR VH

US units

Capacity

Liquid capacity [TR]

Type	Liquid capacity ¹⁾ at pressure drop across valve Δp [psi]			
	NRV			NRV/NRVH
	0.73	1.02	2.03	4.4 ²⁾

R32

Type	0.73	1.02	2.03	4.4
NRV/NRVH 6	1.00	3.10	4.30	6.40
NRV/NRVH 10	2.00	6.60	9.30	13.7
NRV/NRVH 12	9.50	11.2	15.9	23.4
NRV/NRVH 16	16.7	19.8	27.9	41.0
NRV/NRVH 19	25.5	30.2	42.6	62.7
NRV/NRVH 22	39.5	46.6	65.8	96.9

R290

Type	0.73	1.02	2.03	4.4
NRV/NRVH 6	0.80	2.40	3.40	5.10
NRV/NRVH 10	1.60	5.20	7.40	10.9
NRV/NRVH 12	7.60	8.90	12.6	18.6
NRV/NRVH 16	13.3	15.7	22.1	32.6
NRV/NRVH 19	20.3	24.0	33.8	49.8
NRV/NRVH 22	31.3	37.1	52.3	77.0

R600

Type	0.73	1.02	2.03	4.4
NRV/NRVH 6	0.90	2.80	3.90	5.70
NRV/NRVH 10	1.80	5.90	8.40	12.3
NRV/NRVH 12	8.60	10.1	14.3	21.0
NRV/NRVH 16	15.0	17.8	25.1	36.9
NRV/NRVH 19	23.0	27.1	38.3	56.4
NRV/NRVH 22	35.5	41.9	59.2	87.1

R600a

Type	0.73	1.02	2.03	4.4
NRV/NRVH 6	0.80	2.50	3.50	5.10
NRV/NRVH 10	1.60	5.30	7.40	10.9
NRV/NRVH 12	7.60	9.00	12.7	18.7
NRV/NRVH 16	13.4	15.8	22.3	32.8
NRV/NRVH 19	20.4	24.1	34.1	50.1
NRV/NRVH 22	31.6	37.3	52.6	77.5

¹⁾ Rated liquid capacities are based on:
 - Evaporating temperature, $t_e = 14^\circ\text{F}$
 - Condensing temperature, $t_c = 86^\circ\text{F}$
 - Subcooling $\Delta t_{\text{sub}} = 9^\circ\text{F}$

²⁾ Capacity for NR VH
 The table values refer to the evaporator capacity

Suction vapour capacity [TR]

Type	Pressure drop across valve Δp [psi]	Suction vapour capacity ¹⁾ at evaporating temperature t_e [$^\circ\text{F}$]			
		-22	14	32	41

R32

Type	-22	14	32	41
NRV/NRVH 6	1.02	0.26	0.39	0.47
NRV/NRVH 10	1.02	0.56	0.84	1.00
NRV/NRVH 12	0.73	0.82	1.22	1.45
NRV/NRVH 16	0.73	1.44	2.14	2.55
NRV/NRVH 19	0.73	2.20	3.26	3.89
NRV/NRVH 22	0.73	3.39	5.05	6.01

R290

Type	-22	14	32	41
NRV/NRVH 6	1.02	0.20	0.30	0.36
NRV/NRVH 10	1.02	0.42	0.65	0.78
NRV/NRVH 12	0.73	0.61	0.94	1.13
NRV/NRVH 16	0.73	1.07	1.64	1.99
NRV/NRVH 19	0.73	1.63	2.51	3.04
NRV/NRVH 22	0.73	2.52	3.88	4.70

R600

Type	-22	14	32	41
NRV/NRVH 6	1.02	0.08	0.15	0.19
NRV/NRVH 10	1.02	0.17	0.32	0.41
NRV/NRVH 12	0.73	0.26	0.47	0.60
NRV/NRVH 16	0.73	0.46	0.83	1.06
NRV/NRVH 19	0.73	0.70	1.26	1.61
NRV/NRVH 22	0.73	1.08	1.95	2.50

R600a

Type	-22	14	32	41
NRV/NRVH 6	1.02	0.10	0.17	0.22
NRV/NRVH 10	1.02	0.21	0.37	0.47
NRV/NRVH 12	0.73	0.32	0.54	0.69
NRV/NRVH 16	0.73	0.56	0.96	1.20
NRV/NRVH 19	0.73	0.85	1.46	1.84
NRV/NRVH 22	0.73	1.32	2.26	2.84

¹⁾ Rated suction vapour capacities are based on:
 - Suction superheat $sh = 0^\circ\text{F}$
 - Condensing temperature, $t_c = 86^\circ\text{F}$
 - Subcooling $\Delta t_{\text{sub}} = 9^\circ\text{F}$

The table values refer to the evaporator capacity

Hot gas capacity [TR]

Type	Hot gas capacity ¹⁾ at pressure drop across valve Δp [psi]			
	NRV			NRV/NRVH
	0.73	1.02	2.03	4.4 ²⁾

R32

Type	0.73	1.02	2.03	4.4
NRV/NRVH 6	0.20	0.50	0.70	1.10
NRV/NRVH 10	0.30	1.10	1.60	2.30
NRV/NRVH 12	1.60	1.90	2.70	4.00
NRV/NRVH 16	2.90	3.40	4.80	7.00
NRV/NRVH 19	4.40	5.20	7.30	10.7
NRV/NRVH 22	6.80	8.00	11.3	16.5

R290

Type	0.73	1.02	2.03	4.4
NRV/NRVH 6	0.10	0.40	0.60	0.80
NRV/NRVH 10	0.30	0.90	1.20	1.80
NRV/NRVH 12	1.20	1.50	2.10	3.00
NRV/NRVH 16	2.20	2.60	3.60	5.30
NRV/NRVH 19	3.30	3.90	5.50	8.10
NRV/NRVH 22	5.10	6.10	8.50	12.4

R600

Type	0.73	1.02	2.03	4.4
NRV/NRVH 6	0.10	0.20	0.30	0.50
NRV/NRVH 10	0.20	0.50	0.70	1.00
NRV/NRVH 12	0.80	0.90	1.20	1.70
NRV/NRVH 16	1.30	1.60	2.20	3.10
NRV/NRVH 19	2.00	2.40	3.30	4.70
NRV/NRVH 22	3.10	3.70	5.10	7.20

R600a

Type	0.73	1.02	2.03	4.4
NRV/NRVH 6	0.10	0.30	0.40	0.50
NRV/NRVH 10	0.20	0.60	0.80	1.10
NRV/NRVH 12	0.80	1.00	1.30	1.90
NRV/NRVH 16	1.40	1.70	2.40	3.40
NRV/NRVH 19	2.20	2.60	3.60	5.20
NRV/NRVH 22	3.40	4.00	5.60	8.00

¹⁾ Rated hot gas capacities are based on:
 - Evaporating temperature, $t_e = 14^\circ\text{F}$
 - Condensing temperature, $t_c = 86^\circ\text{F}$
 - Subcooling $\Delta t_{\text{sub}} = 9^\circ\text{F}$
 - Hot gas temperature, $t_h = 140^\circ\text{F}$ ahead of the valve
 - Discharge temperature, $t_d = 176^\circ\text{F}$ after compressor

²⁾ Capacity for NR VH
 The table values refer to the evaporator capacity

Correction factors

When selecting the evaporator capacity is to be multiplied by a correction factor depending on the liquid temperature t_l ahead of the valve/the evaporator. The corrected capacity can then be found from the table.

Correction factors for liquid temperature t_l

t_l [$^\circ\text{F}$]	14	32	50	59	68	77	86	95	104	113	122
R32	0.76	0.82	0.88	0.92	0.96	1.00	1.05	1.11	1.17	1.24	1.33
R290	0.73	0.79	0.86	0.90	0.95	1.00	1.06	1.12	1.19	1.28	1.38
R600	0.77	0.82	0.88	0.92	0.96	1.00	1.05	1.10	1.16	1.22	1.29
R600a	0.75	0.80	0.87	0.91	0.95	1.00	1.05	1.11	1.18	1.25	1.33



Note: Only solder version, connection sizes from 6 s to 22 s are allowed for flammable refrigerant.
 - For capacity calculation of other refrigerants, please contact Danfoss.

Data sheet | Check valve, types NRV and NR VH

Capacity

US units

Liquid capacity [TR]

Type	Liquid capacity ¹⁾ at pressure drop across valve Δp [psi]			
	NRV			NRV/ NRVH
	0.73	1.02	2.03	4.4 ²⁾

R1270

NRV/NRVH 6	0.80	2.50	3.60	5.30
NRV/NRVH 10	1.70	5.40	7.70	11.3
NRV/NRVH 12	7.80	9.30	13.1	19.2
NRV/NRVH 16	13.8	16.3	23.0	33.8
NRV/NRVH 19	21.0	24.9	35.1	51.6
NRV/NRVH 22	32.5	38.4	54.2	79.8

R452B

NRV/NRVH 6	0.79	2.6	3.6	5.3
NRV/NRVH 10	1.7	5.5	7.8	11.4
NRV/NRVH 12	8.0	9.4	13.3	19.5
NRV/NRVH 16	14.0	16.5	23.3	34.3
NRV/NRVH 19	21.3	25.2	35.6	52.4
NRV/NRVH 22	33.0	39.0	55.0	80.9

R454B

NRV/NRVH 6	0.80	2.50	3.50	5.20
NRV/NRVH 10	1.70	5.40	7.60	11.1
NRV/NRVH 12	7.70	9.20	12.9	19.0
NRV/NRVH 16	13.6	16.1	22.7	33.4
NRV/NRVH 19	20.8	24.6	34.6	51.0
NRV/NRVH 22	32.1	38.0	53.5	78.8

R1234yf

NRV/NRVH 6	0.50	1.50	2.10	3.10
NRV/NRVH 10	1.00	3.20	4.50	6.70
NRV/NRVH 12	4.70	5.50	7.80	11.4
NRV/NRVH 16	8.20	9.70	13.6	20.1
NRV/NRVH 19	12.5	14.8	20.8	30.7
NRV/NRVH 22	19.3	22.8	32.2	47.4

¹⁾ Rated liquid capacities are based on:

- Evaporating temperature, $t_e = 14^\circ\text{F}$
- Condensing temperature, $t_c = 86^\circ\text{F}$
- Subcooling $\Delta t_{\text{sub}} = 9^\circ\text{F}$

²⁾ Capacity for NR VH

The table values refer to the evaporator capacity

Suction vapour capacity [TR]

Type	Pressure drop across valve Δp [psi]	Suction vapour capacity ¹⁾ at evaporating temperature t_e [$^\circ\text{F}$]			
		-22	14	32	41

R1270

NRV/NRVH 6	1.02	0.22	0.34	0.41	0.44
NRV/NRVH 10	1.02	0.48	0.72	0.87	0.95
NRV/NRVH 12	0.73	0.70	1.05	1.26	1.37
NRV/NRVH 16	0.73	1.22	1.84	2.21	2.41
NRV/NRVH 19	0.73	1.87	2.81	3.38	3.68
NRV/NRVH 22	0.73	2.88	4.35	5.22	5.69

R452B

NRV/NRVH 6	1.02	0.20	0.31	0.37	0.41
NRV/NRVH 10	1.02	0.43	0.66	0.80	0.87
NRV/NRVH 12	0.73	0.63	0.95	1.15	1.26
NRV/NRVH 16	0.73	1.10	1.68	2.02	2.21
NRV/NRVH 19	0.73	1.68	2.56	3.09	3.38
NRV/NRVH 22	0.73	2.59	3.96	4.78	5.22

R454B

NRV/NRVH 6	1.02	0.22	0.33	0.39	0.43
NRV/NRVH 10	1.02	0.46	0.70	0.84	0.92
NRV/NRVH 12	0.73	0.67	1.01	1.22	1.33
NRV/NRVH 16	0.73	1.18	1.78	2.14	2.33
NRV/NRVH 19	0.73	1.80	2.72	3.26	3.56
NRV/NRVH 22	0.73	2.78	4.20	5.05	5.50

R1234yf

NRV/NRVH 6	1.02	0.09	0.16	0.20	0.22
NRV/NRVH 10	1.02	0.20	0.34	0.43	0.47
NRV/NRVH 12	0.73	0.29	0.49	0.62	0.69
NRV/NRVH 16	0.73	0.52	0.86	1.09	1.21
NRV/NRVH 19	0.73	0.79	1.32	1.66	1.85
NRV/NRVH 22	0.73	1.22	2.04	2.56	2.85

¹⁾ Rated suction vapour capacities are based on:

- Suction superheat $sh = 0^\circ\text{F}$
- Condensing temperature, $t_c = 86^\circ\text{F}$
- Subcooling $\Delta t_{\text{sub}} = 9^\circ\text{F}$

The table values refer to the evaporator capacity

Hot gas capacity [TR]

Type	Hot gas capacity ¹⁾ at pressure drop across valve Δp [psi]			
	NRV			NRV/ NRVH
	0.73	1.02	2.03	4.4 ²⁾

R1270

NRV/NRVH 6	0.10	0.40	0.60	0.90
NRV/NRVH 10	0.30	0.90	1.30	1.90
NRV/NRVH 12	1.40	1.60	2.30	3.30
NRV/NRVH 16	2.40	2.80	4.00	5.80
NRV/NRVH 19	3.70	4.30	6.10	8.90
NRV/NRVH 22	5.70	6.70	9.40	13.8

R452B

NRV/NRVH 6	0.14	0.45	0.63	0.92
NRV/NRVH 10	0.30	1.0	1.4	2.0
NRV/NRVH 12	1.4	1.6	2.3	3.4
NRV/NRVH 16	2.4	2.9	4.1	5.9
NRV/NRVH 19	3.7	4.4	6.2	9.1
NRV/NRVH 22	5.8	6.8	9.6	14.0

R454B

NRV/NRVH 6	0.10	0.40	0.60	0.90
NRV/NRVH 10	0.30	1.00	1.40	2.00
NRV/NRVH 12	1.40	1.60	2.30	3.40
NRV/NRVH 16	2.40	2.90	4.10	5.90
NRV/NRVH 19	3.70	4.40	6.20	9.10
NRV/NRVH 22	5.80	6.80	9.60	14.0

R1234yf

NRV/NRVH 6	0.10	0.20	0.30	0.50
NRV/NRVH 10	0.10	0.50	0.70	1.00
NRV/NRVH 12	0.70	0.80	1.20	1.70
NRV/NRVH 16	1.20	1.50	2.00	3.00
NRV/NRVH 19	1.90	2.20	3.10	4.50
NRV/NRVH 22	2.90	3.40	4.80	7.00

¹⁾ Rated hot gas capacities are based on:

- Evaporating temperature, $t_e = 14^\circ\text{F}$
- Condensing temperature, $t_c = 86^\circ\text{F}$
- Subcooling $\Delta t_{\text{sub}} = 9^\circ\text{F}$
- Hot gas temperature, $t_h = 140^\circ\text{F}$ ahead of the valve
- Discharge temperature, $t_d = 176^\circ\text{F}$ after compressor

²⁾ Capacity for NR VH

The table values refer to the evaporator capacity

Correction factors

When selecting the evaporator capacity is to be multiplied by a correction factor depending on the liquid temperature t_l ahead of the valve/the evaporator. The corrected capacity can then be found from the table.

Correction factors for liquid temperature t_l

t_l [$^\circ\text{F}$]	14	32	50	59	68	77	86	95	104	113	122
R1270	0.74	0.79	0.87	0.91	0.95	1.00	1.06	1.12	1.19	1.27	1.37
R452B	0.68	0.71	0.74	0.75	0.76	0.78	0.80	0.81	0.83	0.85	0.87
R454B	0.74	0.80	0.87	0.91	0.95	1.00	1.06	1.12	1.19	1.28	1.38
R1234yf	0.69	0.75	0.84	0.88	0.94	1.00	1.07	1.15	1.25	1.36	1.49

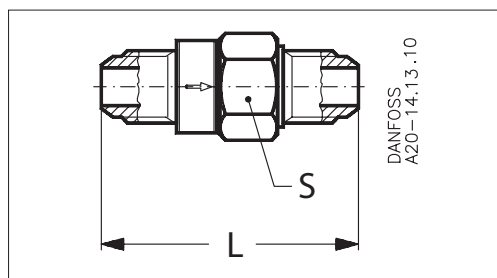

Note: Only solder version, connection sizes from 6 s to 22 s are allowed for flammable refrigerant.
- For capacity calculation of other refrigerants, please contact Danfoss.

Dimensions and weights
NRV 6 - 19

Flare straightway connection - SI Units

Type	Size		L [mm]	Spanner flats S [mm]	Net weight [kg]
	[in]	[mm]			
NRV 6	1/4	6	55	19	0.07
NRV 10	3/8	10	60	19	0.08
NRV 12	1/2	12	70	24	0.14
NRV 16	5/8	16	81	28	0.20
NRV 19	3/4	19	95	34	0.34

Flare straightway connection - US Units

Type	Size	L [in]	Spanner flats S [in]	Net weight [lbs]
	[in]			
NRV 6	1/4	2.17	0.75	0.15
NRV 10	3/8	2.36	0.75	0.19
NRV 12	1/2	2.76	0.94	0.30
NRV 16	5/8	3.19	1.10	0.45
NRV 19	3/4	3.74	1.34	0.75

Data sheet | Check valve, types NRV and NRVH

Dimensions and weights

NRV 6s - 19s / NRVH 6s - 19s

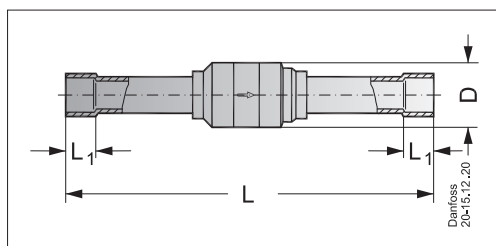

Solder straightway connection - SI Units

Type	Size		L [mm]	L ₁ [mm]	øD [mm]	Net weight [kg]
	[in]	[mm]				
NRV/NRVH 6s	1/4	6	92	7	18	0.06
NRV/NRVH 6s ¹⁾	3/8	10	95	9	18	0.07
NRV/NRVH 10s	3/8	10	109	9	18	0.06
NRV/NRVH 10s ¹⁾	1/2	12	109	10	18	0.07
NRV/NRVH 12s	1/2	12	131	10	22	0.10
NRV/NRVH 12s ¹⁾	5/8	16	131	12	22	0.11
NRV/NRVH 16s	5/8	16	139	12	28	0.17
NRV/NRVH 16s ¹⁾	–	18	139	14	28	0.19
NRV/NRVH 19s	–	18	165	14	34	0.28
NRV/NRVH 16s ¹⁾	3/4	19	139	14	28	0.19
NRV/NRVH 19s	3/4	19	165	14	34	0.29
NRV/NRVH 19s ¹⁾	7/8	22	165	17	34	0.29

Solder straightway connection - US Units

Type	Size	L [in]	L ₁ [in]	øD [in]	Net weight [lbs]
	[in]				
NRV/NRVH 6s	1/4	3.62	0.28	0.71	0.14
NRV/NRVH 6s ¹⁾	3/8	3.74	0.35	0.71	0.16
NRV/NRVH 10s	3/8	4.29	0.35	0.71	0.14
NRV/NRVH 10s ¹⁾	1/2	4.29	0.39	0.71	0.16
NRV/NRVH 12s	1/2	5.16	0.39	0.87	0.22
NRV/NRVH 12s ¹⁾	5/8	5.16	0.47	0.87	0.24
NRV/NRVH 16s	5/8	5.47	0.47	1.10	0.39
NRV/NRVH 16s ¹⁾	3/4	5.47	0.55	1.10	0.43
NRV/NRVH 19s	3/4	6.50	0.55	1.34	0.64
NRV/NRVH 19s ¹⁾	7/8	6.50	0.67	1.34	0.64

¹⁾ Oversize connections.

**Dimensions
and weights**

NRV 22s - 35s / NRVH 22s - 35s

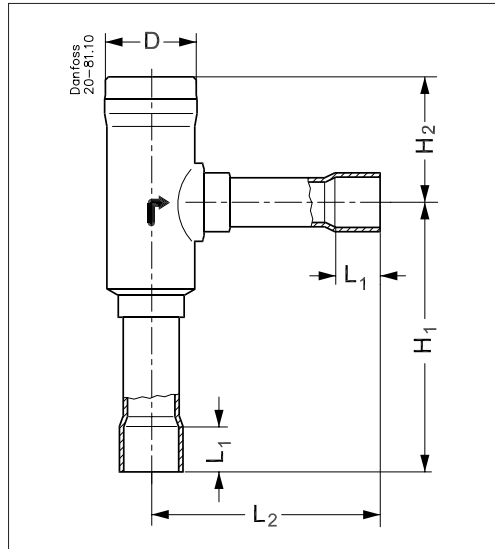

Solder angleway connection - SI Units

Type	Size		H ₁ [mm]	H ₂ [mm]	L ₁ [mm]	L ₂ [mm]	øD [mm]	Net weight [Kg]
	[in]	[mm]						
NRV/NRVH 22s	7/8	22	94	48	17	87	37	0.58
NRV/NRVH 22s ¹⁾	1 1/8	28	94	48	22	87	37	0.61
NRV/NRVH 28s	1 1/8	28	141	67	20	123	49	1.33
NRV/NRVH 28s ¹⁾	1 3/8	35	141	67	25	123	49	1.47
NRV/NRVH 35s	1 3/8	35	141	67	25	123	49	1.40
NRV/NRVH 35s ¹⁾	1 5/8	42	141	67	29	123	49	1.38

Solder angleway connection - US Units

Type	Size	H ₁ [in]	H ₂ [in]	L ₁ [in]	L ₂ [in]	øD [in]	Net weight [lbs]
	[in]						
NRV/NRVH 22s	7/8	3.70	1.89	0.67	3.43	1.46	1.28
NRV/NRVH 22s ¹⁾	1 1/8	3.70	1.89	0.87	3.43	1.46	1.35
NRV/NRVH 28s	1 1/8	5.55	2.64	0.79	4.84	1.93	2.93
NRV/NRVH 28s ¹⁾	1 3/8	5.55	2.64	0.98	4.84	1.93	3.26
NRV/NRVH 35s	1 3/8	5.55	2.64	0.98	4.84	1.93	3.08
NRV/NRVH 35s ¹⁾	1 5/8	5.55	2.64	1.14	4.84	1.93	3.06

¹⁾ Oversize connections.