

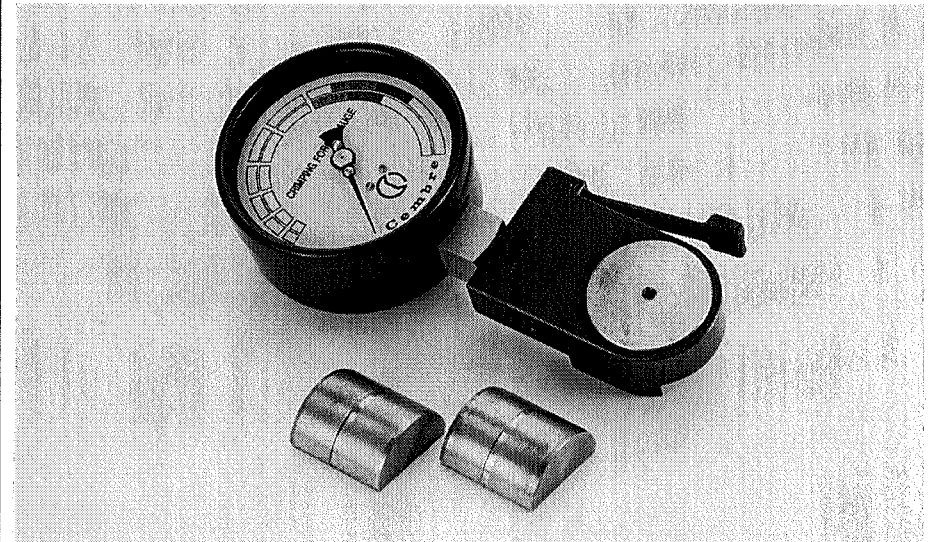

Cembre



DEVICE FOR HYDRAULIC TOOL CRIMPING FORCE TEST "MPC 2"



SERVICE AND MAINTENANCE MANUAL

*This manual is the property of Cembre.
Any reproduction (in full or in part) is forbidden without the prior written permission of Cembre.
Cembre reserve the right to modify the specifications in this catalogue without prior notice.*

 **Cembre** www.cembre.com

Cembre S.p.A.
Via Serenissima, 9
25135 Brescia (Italia)
Telefono: 030 36921
Telefax: 030 3365766
E-mail: info@cembre.com

Cembre Ltd.
Dunton Park
Kingsbury Road, Curdworth - Sutton Coldfield
West Midlands B76 9EB (Great Britain)
Tel.: 01675 470440 - Fax: 01675 470220
E-mail: sales@cembre.co.uk

Cembre S.a.r.l.
22 Avenue Ferdinand de Lesseps
91420 Morangis (France)
Tél.: 01 60 49 11 90 - Fax: 01 60 49 29 10
B.P. 37 - 91421 Morangis Cédex
E-mail: info@cembre.fr

Cembre España S.L.
Calle Llanos de Jerez, 2 - P.I. de Coslada
28823 Coslada - Madrid (España)
Teléfono: 91 4852580
Telefax: 91 4852581
E-mail: info@cembre.es

Cembre AS
Fossnes Senter
N-3160 Stokke (Norway)
Phone: (47) 33361765
Telefax: (47) 33361766
E-mail: cembre@cembre.no

Cembre GmbH
Heidemannstraße 166
80939 München (Deutschland)
Telefon: 089/3580676
Telefax: 089/35806777
E-mail: info@cembre.de

Cembre Inc.
Raritan Center Business Park
181 Fieldcrest Avenue
Edison, New Jersey 08837 (USA)
Tel.: (732) 225-7415 - Fax: (732) 225-7414
E-mail: Sales.US@cembreinc.com

"MPC 2" DEVICE

The "MPC 2" has been projected for the handy and quick test of maximum crimping force developed by **Cembre** hydraulic hand tools.

The kit is composed of:

- a hydraulic transducer, made of burnished steel, coupled to a pointer gauge whose dial bears colour bands setting the acceptance range for the tool crimping force.
- an "M TEST-C" set of dies for testing.

1. GENERAL FEATURES

- **Application range:** suitable to test the maximum crimping force of **Cembre** tools type :

- HT 130-C
- HT 120
- HT 120-KV

- **Dimensions:** length 202 mm
width 101 mm
thickness 53 mm

- **Weight:** (transducer + gauge) 1,31 kg
(set of dies for testing) 0,46 kg

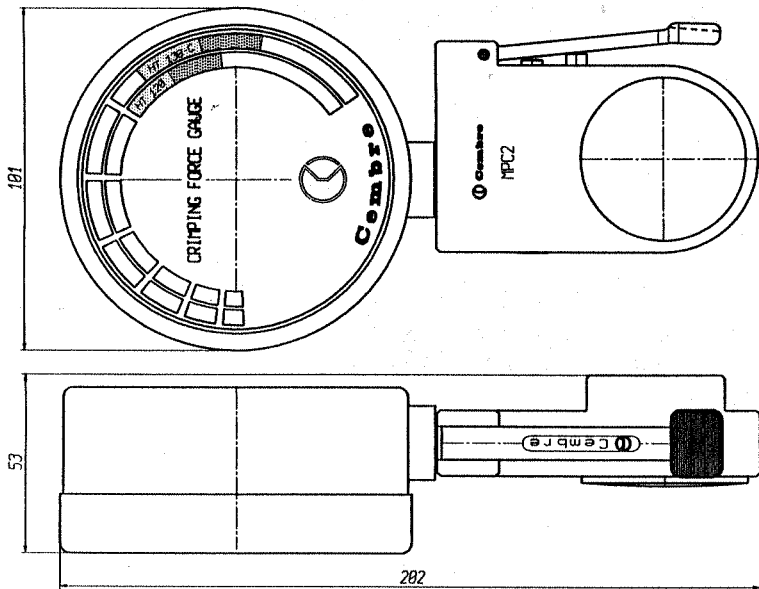

FIG. 1 - DIMENSIONS

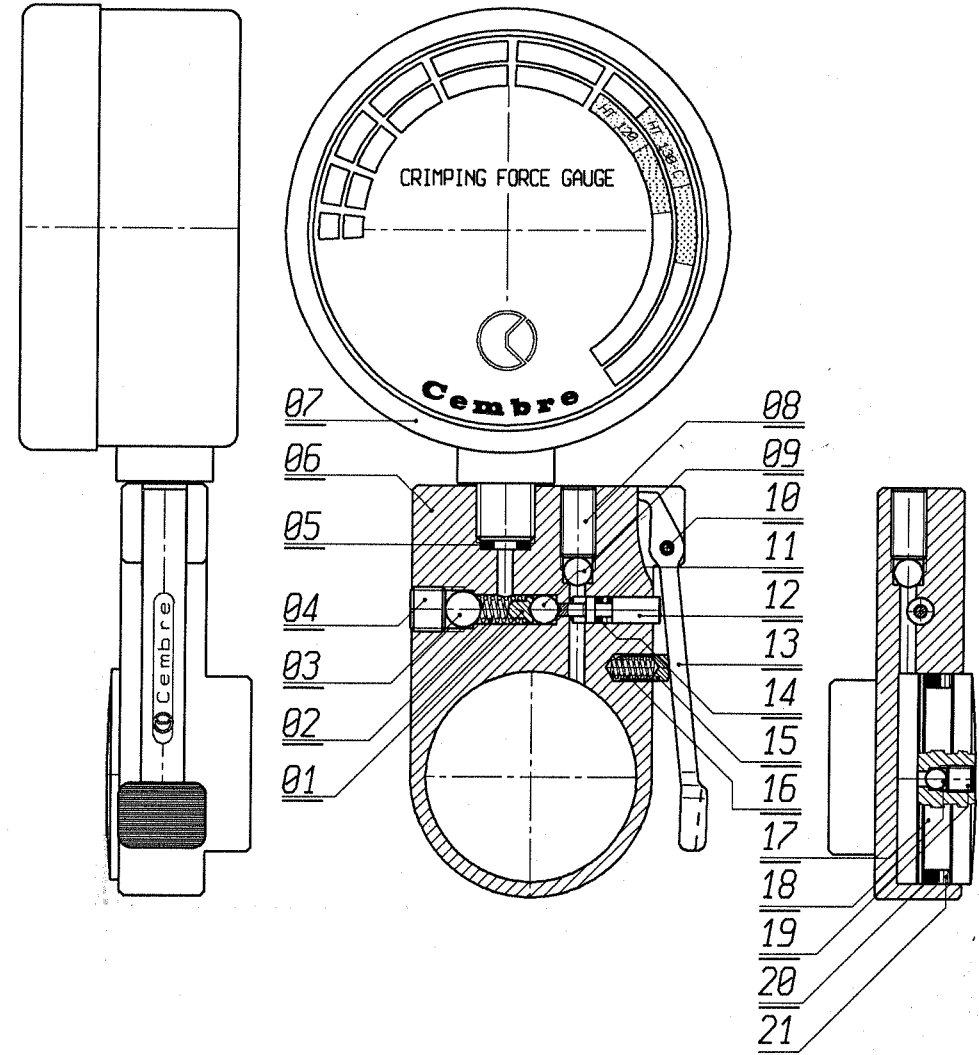

FIG. 6 LONGITUDINAL SECTION VIEW

4. PART LIST (Ref. to fig. 3)

Part.	DESCRIPTION	Q.ty	Part.	DESCRIPTION	Q.ty
*01	BALL POSITIONING DOWEL	1	12	PRESSURE RELEASE SHAFT	1
*02	SPRING	1	13	PRESSURE RELEASE LEVER	1
03	5/16" BALL	1	* 14	O-RING	1
04	M 10 DOWEL	1	15	LEVER RETURN PIN	1
05	COPPER WASHER	1	* 16	SPRING	1
06	BODY	1	17	RAM	1
07	MANOMETER	1	18	3/16" BALL	1
08	M 8x16 DOWEL	1	19	M 6x6 DOWEL	1
*09	1/4" BALL	2	* 20	O-RING	1
10	3x20 SPRING PIN	1	* 21	BACK-UP RING	1
*11	BACK-UP RING	1			

Parts marked with a star (*) are included in the "Servicing kit MPC 2". **Cembre** suggest to change these parts every time the device is disassembled.

Guarantee conditions cease upon usage of not original spare parts.

5. INSTRUCTION FOR RETURNING TOOLS TO Cembre

It is recommended that servicing is performed by an Authorized **Cembre** dealer. Please contact your local representative for advice enclosing, whenever possible, the copy of **Cembre's** Test Certificate, which had been supplied with the device, or quoting date of purchase.

2. INSTRUCTIONS FOR USE

2.1) Setting (Ref. to fig. 2)

With the hydraulic tool in rest position (without oil pressure and the ram (35) completely in rest position) operate as follows:

- Insert one die "M TEST-C" (37) into tool head until it is retained by die/head retainer pin (32). To ease die insertion keep die/head release pin (31) depressed.
- Insert the other die (38) into its seating on ram (35) until retained by die/ram retainer pin (34). It is advisable to advance the ram (35) by 5-8 mm. To facilitate this operation keep die/ram release pin (33) pressed.

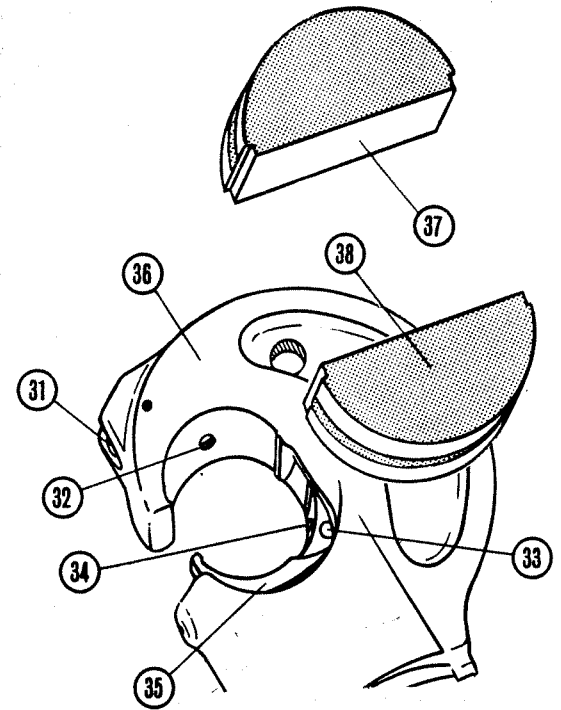

FIG. 2 – DIES INSERTION

2.2) Device positioning (Ref. to fig. 3)

- Insert the hydraulic transducer between the test die halves until the end of the head as show in the figure.



FIG. 3 – DEVICE POSITIONING

2.3) Test (Ref. to fig. 4)

- Position the tool so that both its operating and MPC 2 reading are eased.
- Keeping on operating moveable handle, obtain a slow and gradual advancement of the testing dies until the max pressure valve will come in and a slight “clíc” will be heard. The indicating needle will remain blocked on the maximum crimping force developed by the tool.
- Reopen the dies, releasing the oil pressure of the tool and remove the MPC 2 device.
- Verify that gauge needle indicates a crimping force value within colour band appropriate for the tool tested. Otherwise please return the device to **Cembre** for overhauling (see §5).
- Press the pressure release lever (13), to restore indicating needle to “zero” position.

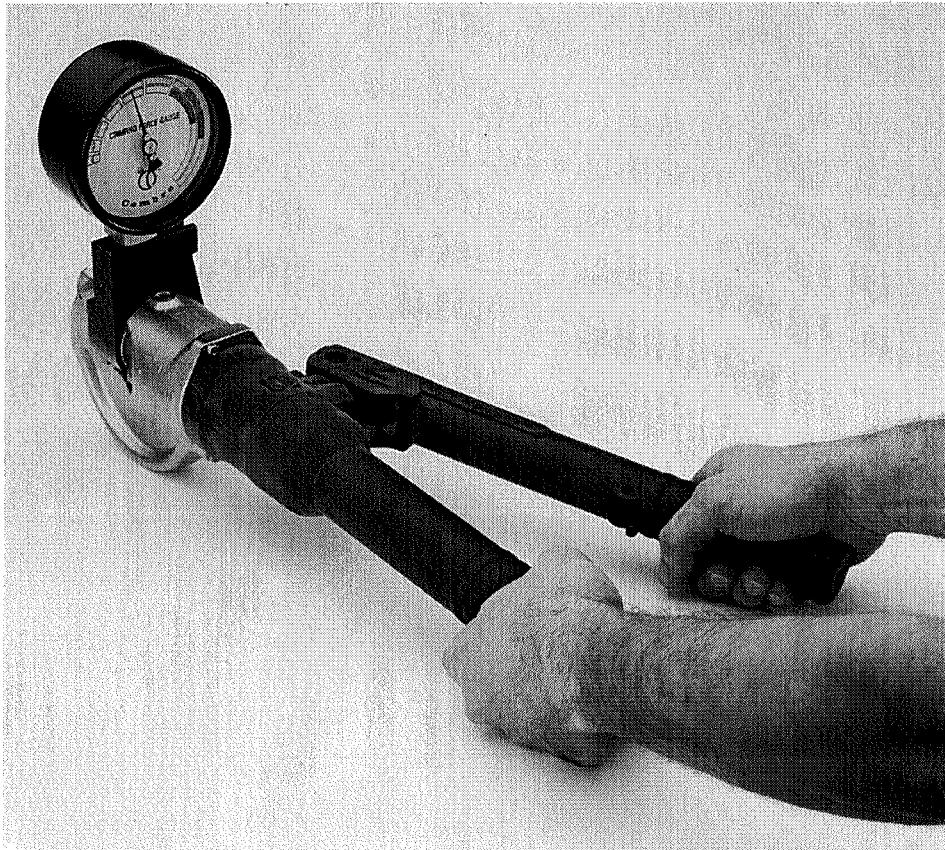

FIG. 4 – TEST

3. MAINTENANCE

The device is sturdy and doesn't need particular care or maintenance. The following cautions are however recommended to warrant a proper performance:

3.1) Accurate cleaning

Bear in mind that dust, sand and dirt are a danger for any hydraulic device. Avoid putting the device on muddy or dusty ground. Any possible solid particle may score the ram producing oil leaks.

The device, after use, must be cleaned with a clean cloth to remove the dirt.

3.2) Storage

It is good rule to store the device in its plastic case properly closed, when not used, to prevent damages from dust or accidental impacts of falls.

This case (type **VAL MPC 2**) measures (350x260x90) mm and weight 0,8 kg.



FIG. 5 – STORAGE CASE