

---

# SAFETY MODULE NA13CT

---



---

## User Manual

---

CARLO GAVAZZI

CE

---

## Table of Contents

1.	INTRODUCTION	.3
2.	PACKAGE CONTENTS	.3
3.	FUNCTION	.3
4.	INSTALLATION.	.4
	4.1 <i>Warning</i>	.4
	4.2 <i>Wiring</i>	.5
	4.3 <i>Power supply</i>	.5
	4.4 <i>E-STOP connection</i>	.5
	4.5 <i>START Circuit</i>	.5
	4.6 <i>Safety Outputs</i>	.5
	4.7 <i>Auxiliary output</i>	.5
5.	OPERATING MODE	.5
6.	TEST & ACTIVATION	.6
7.	USAGE PRECAUTIONS	.6
8.	INSPECTIONS AND MAINTENANCE	.7
9.	APPLICATIONS	.8
10.	TECHNICAL DATA	.10

## 1. INTRODUCTION

This user manual must be read and understood completely, prior to carrying out any operation on the module, by personnel dealing with all the activities of the **NA13CT** safety module. It must be stored in a dry clean place close to where the module is used for easy consultation.

All the operations described in this manual must be carried out by carefully following all the indications given exclusively by specialised personnel.

Contact Carlo Gavazzi and do not carry out any operations on the safety module, ensuring the safety of the operators, if there are any doubts over the contents of this manual, or if there is a fault or a malfunction.

The user of the module is responsible for the evaluation of the risks of the entire system.

Based on the evaluation and on the standards in force in the country of use, the user decides with complete responsibility that the functions described in the user manual are suitable for use on his machine.

Whenever the **NA13CT** safety module is improperly used, by not following only and all the indications of this manual or whenever these indications are partially, incorrectly or incompletely applied by person-

nel unspecialised and/or insufficiently informed on the contents of this manual and the machine safety directives, Carlo Gavazzi is not responsible for the functioning of the **NA13CT** and its capacity to guarantee the operator's safety.

The **NA13CT** module does not require internal maintenance: if it is tampered or if the case is opened, the module loses its safety functions and the guarantee is annulled.

## 2. PACKAGE CONTENTS

The package contains:

- n.1 safety module model **NT13CT**
- n.1 user manual

If any anomalies are found with the package, its contents or with the safety module do not install and contact Carlo Gavazzi.

## 3. FUNCTION

The safety module **NA13CT** is designed to control emergency stop (E-STOP) devices. It has been designed according to safety category 3 of EN 954-1.

Three N.O. force-guided and delayed safety outputs and one auxiliary delayed N.C. output are available, so that the **NA13CT** safety module is suitable for category 1 E-STOP (EN 60204-1) applications.

The delay is set up to 1 second.

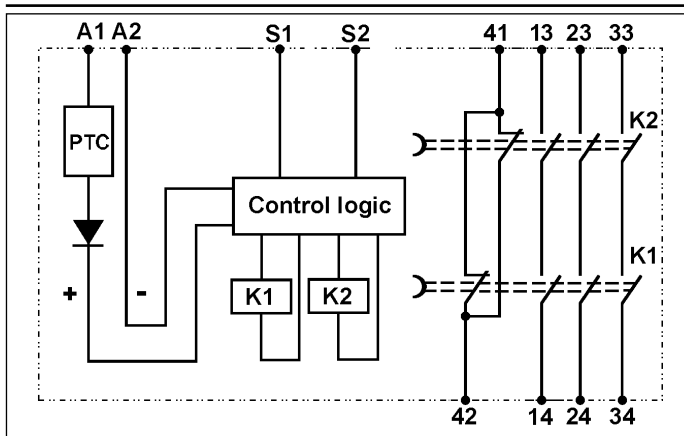

Fig. 1 - NA13CT diagram

## 4. INSTALLATION

### 4.1 Warning

- The NA1/3-C-T safety module must be installed following the standards in force in the country of use, when the machine is not powered and with no dangers for the operator, on the machine's

TERM.	CONNECTION
A1	+24VDC / 18VAC
A2	GND / 18 VAC
S1-S2	Feedback loop and START terminals
13-14 23-24 33-34	N.O. Safety delayed outputs
41-42	N.C. Auxiliary delayed output

Tab. 1: Terminal description

electrical board in a dry and clean place (minimum protection degree: IP54), fixed on the special DIN rail.

- If the safety module is tampered, it can not ensure the safety of the operator any more and the warranty is void.
- To avoid interference due to coupling, run the limit switches connecting conductors separately from the power conductors.
- Avoid the risk of short-circuits between the terminals caused by free cables, wires or material that could come close to the safety module.
- Avoid installation during storms.

- Do not dispose of the packaging in the environment.

## 4.2 Wiring

It is recommended to use conductors with section and length adequate to the terminals, currents and distances involved, ensuring that the conductors are not excessively tight, that their positioning avoids potential cuts or squashing and that they are not in the way of people or things.

## 4.3 Power supply

Connect the A1 & A2 terminals to the power supply source via the E-STOP device(s).

## 4.4 E-STOP connection

The **NA13CT** safety module can be connected to one or more single-channel or double-channel E-STOP devices (see the application examples).

The E-STOP contact(s) must be closed when the E-STOP button is not pushed, open when the E-STOP is pushed.

The contacts of the E-STOP must be connected between the power supply terminals of the module (A1 and eventually A2) and the power supply source, so that when the E-STOP is pushed the safety module is switched off.

## 4.5 START Circuit

The safety module can be configured for manual START (not mon-

itored for welding fault) or automatic START.

To set up the manual START configuration, it is necessary to connect a N.O. pushbutton to the S1-S2 terminals, while to set up the automatic START configuration the two terminals must be short-circuited (directly or via the N.C. contacts of external relays).

## 4.6 Safety Outputs

Three N.O. voltage-free safety outputs are available between the 13-14, 23-24 and 33-34 terminals: their contacts are closed when the safety module is correctly powered, the E-STOP is not pushed, and the START circuit has been activated, as described in this user manual.

## 4.7 Auxiliary output

One N.C. auxiliary voltage-free relay output is available between the 41-42 terminals. It can be used only for signalling functions and not for safety functions.

## 5. OPERATING MODE

With manual START configuration, the safety outputs close and the auxiliary output opens when the E-STOP is not pushed and the N.O. START pushbutton is pressed.

With automatic START configuration, the safety outputs close and the auxiliary output opens as soon as the E-STOP is released (not

pushed).

The **CH1** & **CH2** LEDs turn on as soon as the safety outputs close.

Pushing the E-STOP button leads to a safety condition, forcing the safety outputs to an open status when the delay has expired. The **POWER**, **CH1** & **CH2** LEDs turn off.

A new operating cycle is possible only after releasing the E-STOP button (and pushing the START button, if the safety module has been set up with manual START configuration).

## **6. TEST & ACTIVATION**

The following operations must be repeated when the module is installed and every time the wiring is changed and at regular intervals by carrying out in sequence all the steps described below without any type of dangerous condition for the operators.

**STEP 1** Check the integrity, the correct installation, the correct positioning on the machine and the correct functioning of all the devices connected to the inputs and to the outputs of the **NA13CT** safety module. Check also the correct wiring of all the devices (See 4.2) and the integrity of the labels and documentation.

**STEP 2** Power on the safety module with E-STOP button not pushed: with manual START configuration

the **POWER** LED turns on, while the **CH1** and **CH2** LEDs are off, the safety outputs are open and the auxiliary output is closed (in automatic START configuration all the LEDs are on, the safety outputs are closed and the auxiliary output is open).

Close the N.O.START contact: the safety outputs close, the auxiliary output opens and the **CH1**, **CH2** LEDs turn on.

**STEP 3** Push the E-STOP button: the safety outputs open (after the delay has expired), the auxiliary output closes and the **POWER**, **CH1**, **CH2** LEDs turn off (always when the delay has expired).

Repeat STEP 2 checking that the safety outputs do not close - with manual START configuration - simply releasing the E-STOP device, without pushing the START button.

Check also that the safety outputs do not close, that the auxiliary output does not open, and that the **POWER**, **CH1**, **CH2** LEDs are off simply pushing the START button with E-STOP button pushed.

If more than one E-STOP is used, the STEPS 2 and 3 must be repeated for each device.

## **7. USAGE PRECAUTIONS**

The safety module can check the integrity of external contactors or expansion modules simply con-

necting their N.C. control contacts in series to the START contact (or to the bridge, in automatic START configuration) between S1-S2 terminals.

It is recommended to connect a fuse in series to the safety outputs to reduce the risk of safety outputs contacts welding (see outputs technical data).

Never, in any situation, connect spark quenching unit circuits in parallel to safety outputs contacts: the safety function would no longer be guaranteed.

The safety outputs open with a delay that is defined within a range (see technical data): the user must always consider the worst case (maximum delay allowed by the range) in designing his own machine, in order to avoid the possibility for the operator to reach

hazardous areas when dangerous situations are still active.

The **NA13CT** safety relay can be employed also with mechanical or magnetic limit switches or sensors, if these devices have one/two contacts, closed when there is no danger for the operator (e.g. gate/door closed), open when there are dangerous situations for the operator (e.g. gate/door open).

Never, in any circumstance, exceed the electrical ratings stated in the technical data table of this manual.

## 8. INSPECTIONS AND MAINTENANCE

The integrity of the safety module and of all the connected devices must be checked regularly according to the risk evaluation of the machine, under the complete

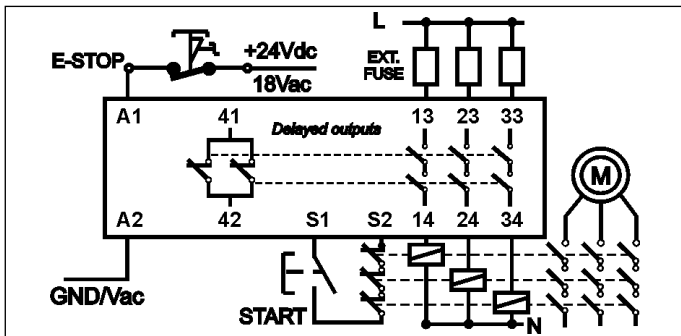

Fig. 2: NA13CT application with one single-channel E-STOP device

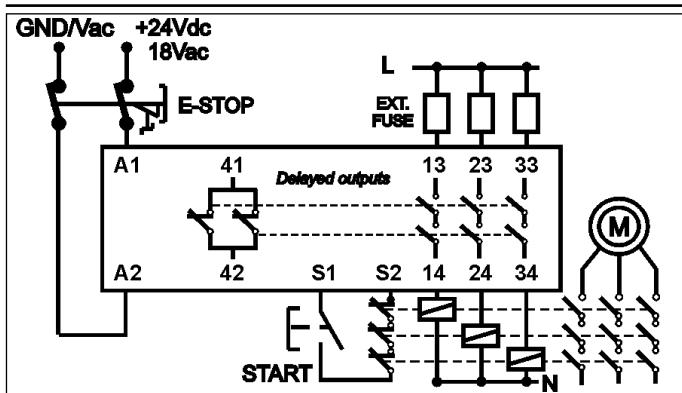

Fig. 3: NA13CT application with one double-channel E-STOP device

responsibility of the user.

Regular inspections must be performed repeating all the operations listed in the **TEST & ACTIVATION** section.

The safety module doesn't require internal maintenance: it must be periodically cleaned - with machine and module powered off - together with all the connected devices, removing dust, liquids and condensation.

## 9. APPLICATIONS

In Fig. 2 and 3, if the one-channel (two-channels) E-STOP button is not pushed, the safety outputs close (with automatic START) or are enabled to close (with manual START). When the E-STOP button

is pushed, the safety module is switched off: the safety outputs open and the auxiliary output closes as soon as the releasing delay has expired.

In Fig. 4 and 5, if both the onechannel (two-channels) E-STOP buttons are not pushed, the safety outputs close (with automatic START) or are enabled to close (with manual START). When even one of the E-STOP buttons is pushed, the safety module is switched off: the safety outputs open and the auxiliary output closes as soon as the releasing delay has expired.



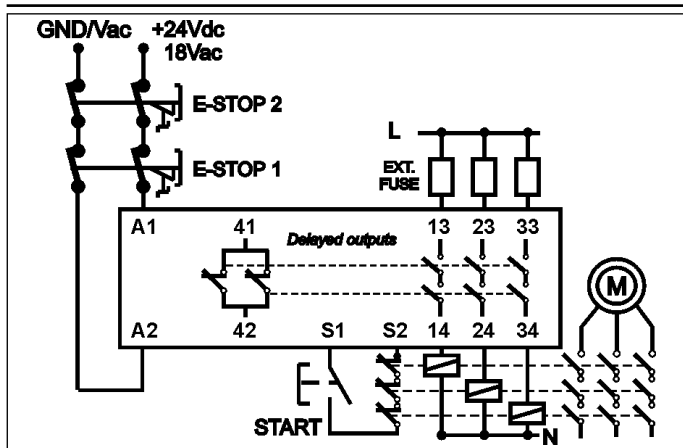

Fig. 4: NA13CT application with two double-channel E-STOP devices

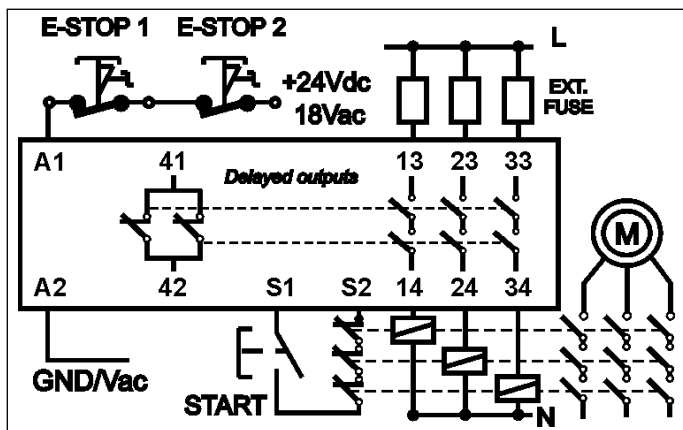

Fig. 5: NA13CT application with two single-channel E-STOP devices

**10. TECHNICAL DATA**

<b>ELECTRICAL CHARACTERISTICS</b>	
Supply Voltage	18 Vac -15/+10% 50 + 60Hz, 24 Vdc -15/+10%
Current Consumption	50 mA (@ 24Vdc, without load)
Power Consumption	Max. 2 VA
Input	1 or 2 N.O. Voltage-free
Safety Category (EN 954-1)	3
E-STOP Category (EN 60204-1)	1
Short-Circuit Protection	Internal PTC
<b>SAFETY OUTPUTS</b>	
Function	Force-guided N.O. contacts
Max Switching Voltage	AC 250 V
Max. Switching Current	6 A
Max. Switching Power (Resistive Load)	1500 VA
Output contacts protection	External fuse: 4 A
Mechanical Life	> 10 <sup>7</sup> switching cycles
Electrical Life (with max. load)	> 10 <sup>5</sup> switching cycles
<b>AUXILIARY OUTPUT</b>	
Function	Force-guided N.C. contacts
Ratings	See Safety Outputs ratings
<b>TIMINGS</b>	
Response time (from E-STOP pushed to safety outputs open): a) @ 24 Vdc	1.0 ± 0.2 seconds
b) Within the supply range	1.0 -0.3/+0.5 seconds
START delay (from START button pushed to safety outputs closed)	Max. 100 ms

<b>LED WARNINGS</b>	
POWER	ON : Module supplied OFF : Module not supplied
CH1 & CH2	ON : Safety outputs closed OFF : Safety outputs open
<b>MECHANICAL AND ENVIRONMENTAL CHARACTERISTICS</b>	
Housing	PA 6.6 flammability class VO-UL94
Fixing	OMEGA - DIN EN 50022 Rail
Protection degree of the module	IP30
Minimum Protection degree of the installation location	IP54
EMC compatibility	EN 61000-6-2; EN 61000-6-3;
Operating Temperature	-20 ÷ 55°C
Storage Temperature	-25 ÷ 75°C
Relative Operating Humidity	10 ÷ 95%
Relative Storage Humidity	10 ÷ 95%
Cross-Section of the cables to connect to the terminals	0.14 ÷ 2.5 mm <sup>2</sup> (rigid & flexible)
Torque setting on connection terminals	0.5 Nm
Dimensions	99 x 22.5 x 115 mm
Weight	200 g



***CARLO GAVAZZI reserves the right to make improvements or changes without prior notice.***