

# PD30CTPS50BPxxIO - IO-Link



Photoelectric Retro-reflective Polarized - PointSpot sensors with IO-Link communication



## Description

The PD30CTPS50BPxxIO are a part of the latest generation of high performance photoelectric sensors designed to solve most detection tasks due to the new IO-Link features.

The sensors are implemented in the compact 10 x 20 x 30 mm ABS housing that are acknowledged world wide.

New implemented functions with weight on functionality, reliability, Predictive maintenance make these sensors ideal for Industry 4.0.

## Benefits

- **Retro-reflective Polarized - PointSpot** sensor with IO-Link with a adjustable distance of 2.5 to 5 m, either by trimmer or via IO-Link.
- **Application functions:** Pattern Recognition, Speed & Length, Divider function and Object & Gap Monitoring.
- **Neighbour Immunity**, selectable up to 3 sensors
- **Easy customization** to specific OEM requests by use of the build in IO-Link functionalities.
- **The output can be operated** either as a standard switching output or in IO-Link mode.
- **Fully configurable via output IO-Link v 1.1.** Electrical outputs can be configured as PNP / NPN / Push-Pull / External input, normally open or normally closed.
- **Timer functions** can be set, such as ON-delay, Off-delay, and one shots.
- **Logging functions:** Temperatures, detecting counter, power cycles and operating hours.
- **Detection modes** Single point, two point and windows mode.
- **Logic functions:** AND, OR, XOR and Gated SR-FF.
- **Analogue output:** In IO-Link mode the sensor will generate 16 bit analogue process data output representing various selectable process data such as received signal level.

 **IO-Link**

## Applications

**Pattern Recognition:** An easy way to verify that a product is manufactured to the specification e.g. Furniture production where tabs or holes has to be with a defined pattern.

**Speed and Length:** Monitor the speed and length of an object on a conveyour for e.g. sorting on size.

**Divider function:** A de-central counting function that gives a signal when a preset count level is reached e.g. when a certain items are packed in a carton box it ask for a new box.

**Object and Gap Monitoring:** Function that can sort out good objects and gaps between them so e.g. a packaging machine only receive objects with the correct size and gaps.

## Main functions

- Detects presence or absence of objects that cut off the light from the emitter
- Detects all opaque objects very reliably
- The PointSpot light source removes halo light and increases detection reliability.



- The sensor can be operated in IO-Link mode once connected to an IO-Link master or in standard I/O mode.
- Received light intensity as process data.
- Neighbour interference protection.
- Sensing distance by potentiometer, teach by wire or by IO-link parameter.
- Quality of Run and Quality of Teach result.
- Temperature data for preventive maintenance.
- Front-end check for preventive maintenance.

**Adjustable parameters via IO-Link interface:**

- Sensing distance and hysteresis.
- Sensing modes: single point or two point or window mode.
- Timer functions, e.g.: On-delay, Off delay, One shot leading edge or trailing edge.
- Logic functions such as: AND, OR, X-OR and SR-FF.
- External input.
- Logging functions: Maximum temperatures, minimum temperatures, operating hours, operating cycles, power cycles, minutes above maximum temperature, minutes below minimum temperature, etc.
- Auto hysteresis
- Special functions: Pattern Recognition, Speed & Length, Divider function and Object & Gap Monitoring.

## References

**Product selection key**

**PD30CTPS50BP  IO**

Enter the code option instead of

Code	Option	Description
P	-	Sensing principle: Photoelectric sensor
D	-	Rectangular housing
30	-	Length of housing
C	-	Plastic housing
T	-	Top trimmer
P	-	Polarized retro-reflective
S	-	PointSpot
50	-	Sensing distance: 5 m
B	-	<b>Selectable functions:</b> NPN, PNP, Push-Pull, External Input (only pin 2) or External teach input (only pin 2)
P	-	<b>Selectable:</b> N.O. or N.C.
<input type="checkbox"/>	A2	Cable, 2 m
	M5	Connector M8
IO	-	IO-Link version

**Type selection**

Connec-tion	Housing	Light type	Code
Cable	Plastic housing	Red	<b>PD30CTPS50BPA2IO</b>
Plug	Plastic housing	Red	<b>PD30CTPS50BPM5IO</b>

## Structure

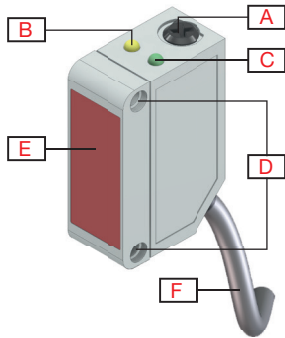

Fig. 1 Cable

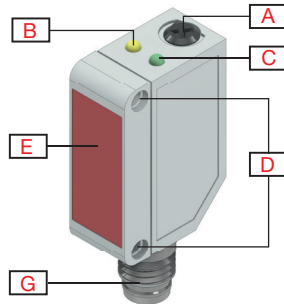

Fig. 2 Plug

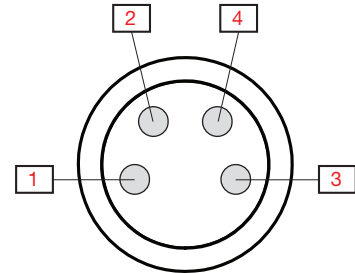
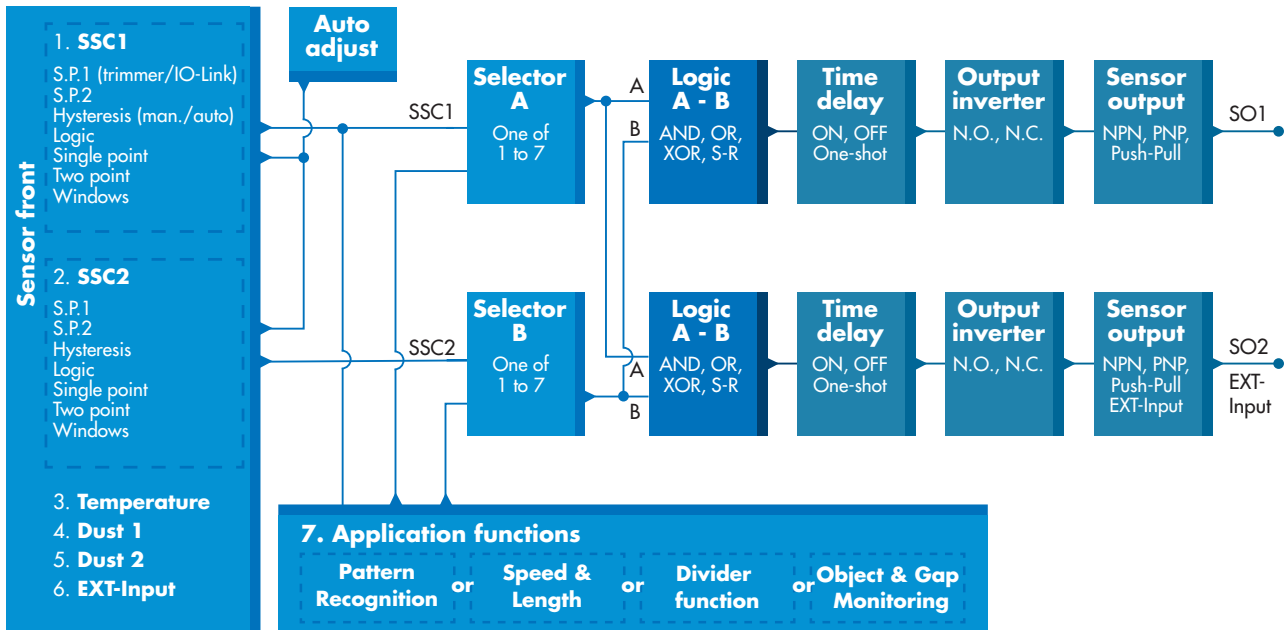

Fig. 3 "M8-plug" Pin numbers

<b>A</b>	Sensitivity adjustment (Top trimmer)	<b>G</b>	M8, 4-pin male connector
<b>B</b>	Yellow LED	<b>1</b>	Brown
<b>C</b>	Green LED	<b>2</b>	White
<b>D</b>	M3 Fixing holes for sensor mounting	<b>3</b>	Blue
<b>E</b>	Sensing window	<b>4</b>	Black
<b>F</b>	2 m, 4 wire PVC Ø 3.3 mm cable		

# Sensing

## Detection





<b>Sensor switching channel SSC1 and SSC2</b>	<b>SSC1</b> <ul style="list-style-type: none"> <li>• Enabled</li> <li>• Disabled</li> </ul> <b>Factory settings:</b> Enabled	<b>SSC2</b> <ul style="list-style-type: none"> <li>• Enabled</li> <li>• Disabled</li> </ul> <b>Factory settings:</b> Enabled
<b>Set Point 1 (SP1)</b>	<ul style="list-style-type: none"> <li>• 0 ... 600</li> </ul> <b>Factory settings:</b> 100 (Approx. 5 m @ Reference target, reflector: ER4 (Ø80 mm))	
<b>Set Point 2 (SP2)</b>	<ul style="list-style-type: none"> <li>• 0 ... 600</li> </ul> <b>Factory settings:</b> 600 (Approx. 2.5 m @ Reference target, reflector: ER4 (Ø80 mm))	
<b>Switching logic</b>	<ul style="list-style-type: none"> <li>• High active</li> <li>• Low active</li> </ul> <b>Factory settings:</b> High active	
<b>Switching mode</b>	<b>SSC1</b> <ul style="list-style-type: none"> <li>• Deactivated</li> <li>• Single point mode</li> <li>• Two point mode</li> <li>• Windows mode</li> </ul> <b>Factory settings:</b> Single point mode	<b>SSC2</b> <ul style="list-style-type: none"> <li>• Deactivated</li> <li>• Single point mode</li> <li>• Two point mode</li> <li>• Windows mode</li> </ul> <b>Factory settings:</b> Single point mode
<b>Rated operating distance (S<sub>n</sub>)</b>	≤ 5 m	@ Reference target, reflector: ER4 (Ø80 mm)
	≤ 3 m	@ Reference target, reflector: ER4060
<b>Maximum detection distance</b>	< 5 m	@ Reference target, reflector: ER4 (Ø80 mm)
<b>Sensitivity control (selectable between)</b>	<ul style="list-style-type: none"> <li>• IO-Link Adjustment (SSC1)</li> <li>• Trimmer Input (SSC1)</li> <li>• Teach by wire (SSC1)</li> </ul> <b>Factory settings:</b> Trimmer Input	
<b>Sensitivity adjustment</b>	70 ... 500	Single-turn potentiometer
<b>Blind zone</b>	≤ 100 mm @ S <sub>n</sub> max	@ reflector ER4, Ø80 or ER4060
<b>Light source / Light type</b>	620 nm / Red modulated	
<b>Detection angle</b>	± 0.6°	@ 2.5 m (half sensing distance)
<b>Light spot size</b>	Ø 9.5 cm	@ 2.5 m (half sensing distance)
<b>Emitter beam angle</b>	± 1.0°	@ 2.5 m (half sensing distance)
<b>Adjustable distance</b>	<ul style="list-style-type: none"> <li>• 0 ... 600</li> </ul> <b>Factory settings:</b> SP1 100 (5 m) and SP2 600 (2.5 m)	@ Reference target, reflector: ER4 (Ø80 mm)
<b>Hysteresis (H)</b>	Adjustable by IO-Link	
<b>Manual</b>	• 1% ... 100%	
<b>Automatic</b>	Typical 5% ... 10% / Max. 15%	
<b>Detection filter</b>	This function can increase the immunity towards unstable targets and electromagnetic disturbances: Value can be set from 1 to 255. <b>Factory settings:</b> 1 (1 is max. operating frequency and 255 is min. operating frequency)	
<b>Mutual Inteferece Protection</b>	<ul style="list-style-type: none"> <li>• MIP Off</li> <li>• One channel</li> <li>• 2 channels - CH A</li> <li>• 2 channels - CH B</li> <li>• 3 channels - CH A</li> <li>• 3 channels - CH B</li> <li>• 3 channels - CH C</li> </ul>	<b>Factory settings:</b> MIP Off



**Application functions**

<b>Selectable dedicated applications</b>	<ul style="list-style-type: none"> <li>• No application</li> <li>• Pattern Recognition</li> <li>• Speed and Length</li> <li>• Divider function</li> <li>• Object and Gap Monitoring</li> </ul>	<b>Factory settings:</b> No application
--	--	---

### Pattern Recognition

<b>Function description</b>	The Pattern recognition function detects a pattern (e.g. a row of holes or pins) and compare the order with a pre-taught reference pattern.	
<b>Conditions</b>	Two sensors (Main sensor and Trigger sensor) are needed for this function.	
<b>Settings</b>	<ul style="list-style-type: none"> <li>• The Trigger sensor has to detect the full length of the body that contains the pattern.</li> <li>• The Main sensor has to be aimed at the e.g. holes or pins that constitute the pattern.</li> </ul>	

### Speed and Length

<b>Function description</b>	This function is designed to monitor the length of an object as well as the speed of a conveyour belt. The actual value if the length in [mm] and the speed in [mm/s] are directly available on the IO-Link master.	
<b>Conditions</b>	Two sensors (Main sensor and Trigger sensor) are needed for this function.	
<b>Settings</b>	Distance between sensors.	25 ... 150 mm <b>Factory settings:</b> 100 mm

### Divider function

<b>Function description</b>	This function can be used to e.g. monitor how many items that are packed into a carton box. Once the preset number is reached the sensor gives an output so the full box can be replaced.	
<b>Conditions</b>	Only one sensor is needed for this function.	
<b>Settings</b>	A counter value must be set in the sensor.	
<b>Settings</b>	Counter limit.	1...60 000 <b>Factory settings:</b> 5



## Object and Gap Monitoring

<b>Function description</b>	This function is designed to monitor, that the length of an object and the gap between the following object on a conveyer belt, are within certain limits.	
<b>Conditions</b>	Only one sensor is needed for this function.	
<b>Settings</b>	An acceptable minimum and maximum time [ms] must be set for both the object size a gap size between two objects represented by the time it takes to pass the sensor.	
	Object minimum time.	10...60 000 ms <b>Factory settings:</b> 500 ms
	Object maximum time.	10...60 000 ms <b>Factory settings:</b> 10 000 ms
	Gap minimum time.	10...60 000 ms <b>Factory settings:</b> 500 ms
	Gap maximum time.	10...60 000 ms <b>Factory settings:</b> 10 000 ms
<b>Outputs</b>	Output 1 is active when an object is outside the set limits. Output 2 is active when the gap between two objects is outside the set limits.	

### Alarm settings

<b>Safe limits</b>	<b>SSC1</b> • 0 ... 100 % of actual SP <b>Factory settings:</b> 20%	<b>SSC2</b> • 0 ... 100 % of actual SP <b>Factory settings:</b> 20%
<b>Dust alarm</b>	Safe limits are used for dust alarm level.	
<b>Water drop alarm</b>	Safe limits are used for water drop alarm level.	
<b>Temperature alarm</b>	<ul style="list-style-type: none"> <li>• High threshold -30 ... +70 °C</li> <li>• Low threshold -30 ... +70 °C</li> </ul> <b>Factory settings:</b> High value 70 °C Low value -30 °C	

### Detection diagram

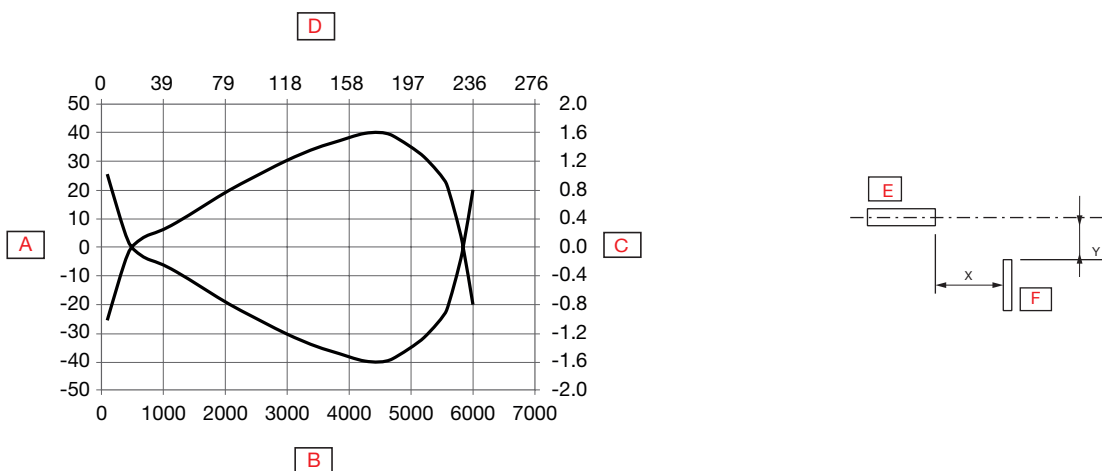

<b>A</b>	Detection width (mm)	<b>D</b>	Sensing range (inches)
<b>B</b>	Sensing range (mm)	<b>E</b>	Sensor
<b>C</b>	Detection width (inches)	<b>F</b>	ER4 reflector



**Accuracy**

Temperature drift	≤ 0.2%/°C
-------------------	-----------

**Excess gain**

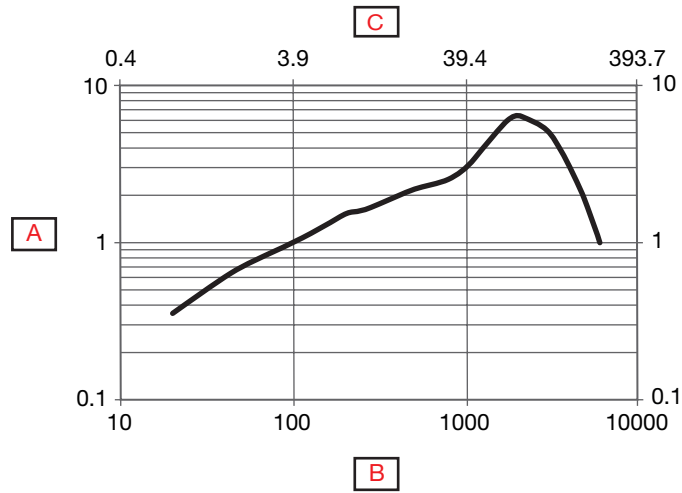

<b>A</b>	Excess gain	<b>C</b>	Distance (inches)
<b>B</b>	Distance mm		





# Features

## ▶ Power Supply

Rated operational voltage ( $U_B$ )	10 ... 30 VDC (ripple included)
Ripple ( $U_{rpp}$ )	≤ 10%
No load supply current ( $I_o$ )	≤ 30 mA @ $U_B$ min. ≤ 15 mA @ $U_B$ max.
Power-ON delay ( $t_v$ )	≤ 150 ms

## ▶ Auto adjust

Auto adjust	<b>SSC1</b> • ON • OFF <i>Factory settings: OFF</i>	<b>SSC2</b> • ON • OFF <i>Factory settings: OFF</i>
-------------	--	--

## ▶ Input selector

Input selector	<b>Channel A</b> • Deactivated • SSC1 • SSC2 • Dust alarm 1 • Dust alarm 2 • Temperature alarm • External input • Application functions <i>Factory settings: SSC1</i>	<b>Channel B</b> • Deactivated • SSC1 • SSC2 • Dust alarm 1 • Dust alarm 2 • Temperature alarm • External input • Application functions <i>Factory settings: SSC1</i>
----------------	--	--

## ▶ Logic functions

Logic functions	<b>Channel A + B for SO1</b> • Direct • AND • OR • X-OR • SR-FF <i>Factory settings: Direct</i>	<b>Channel A + B for SO2</b> • Direct • AND • OR • X-OR • SR-FF <i>Factory settings: Direct</i>
-----------------	---	---



**Time delays**

<b>Timer mode</b>	<b>For SO1</b> <ul style="list-style-type: none"> <li>• Disabled</li> <li>• ON delay</li> <li>• OFF delay</li> <li>• ON delay and OFF delay</li> <li>• One-shot leading edge</li> <li>• One-shot trailing edge</li> </ul> <b>Factory settings: Disabled</b>	<b>For SO2</b> <ul style="list-style-type: none"> <li>• Disabled</li> <li>• ON delay</li> <li>• OFF delay</li> <li>• ON delay and OFF delay</li> <li>• One-shot leading edge</li> <li>• One-shot trailing edge</li> </ul> <b>Factory settings: Disabled</b>
<b>Timer scale</b>	<b>For SO1</b> <ul style="list-style-type: none"> <li>• [ms]</li> <li>• [s]</li> <li>• [min]</li> </ul> <b>Factory settings: ms</b>	<b>For SO2</b> <ul style="list-style-type: none"> <li>• [ms]</li> <li>• [s]</li> <li>• [min]</li> </ul> <b>Factory settings: ms</b>
<b>Timer value</b>	<b>For SO1</b> <ul style="list-style-type: none"> <li>• 0 ... 32 767</li> </ul> <b>Factory settings: 0</b>	<b>For SO2</b> <ul style="list-style-type: none"> <li>• 0 ... 32 767</li> </ul> <b>Factory settings: 0</b>

**Outputs**

<b>Sensor output</b>	<b>For SO1 Pin 4 Black wire</b> <ul style="list-style-type: none"> <li>• Disabled output</li> <li>• NPN</li> <li>• PNP</li> <li>• Push-Pull</li> </ul> <b>Factory settings: PNP</b>	<b>For SO2 Pin 2 White wire</b> <ul style="list-style-type: none"> <li>• Disabled output</li> <li>• NPN</li> <li>• PNP</li> <li>• Push-Pull</li> <li>• External input, active high</li> <li>• External input, active low</li> <li>• External teach</li> <li>• Mute input</li> </ul> <b>Factory settings: PNP</b>
<b>Output Inverter</b>	<b>For SO1 Pin 4 Black wire</b> <ul style="list-style-type: none"> <li>• N.O.</li> <li>• N.C.</li> </ul> <b>Factory settings: N.O.</b>	<b>For SO2 Pin 2 White wire</b> <ul style="list-style-type: none"> <li>• N.O.</li> <li>• N.C.</li> </ul> <b>Factory settings: N.C.</b>
<b>Rated operational current (I<sub>o</sub>)</b>	≤ 100mA (continuous) pr. output 100 mA @ 100 nF Load (Short-time) pr. output	
<b>OFF-state current (I<sub>o</sub>)</b>	≤ 50 μA	
<b>Minimum operational current (I<sub>m</sub>)</b>	> 0,5 mA	
<b>Voltage drop (U<sub>d</sub>)</b>	≤ 1.0 VDC @ 100 mA	
<b>Protection</b>	Short circuit, reverse polarity, transients	
<b>Utilization category</b>	DC-12	Control of resistive loads and solid-state loads with optical isolation
	DC-13	Control of electromagnets
<b>Capacitive load</b>	100 nF @ 100 mA, 24 VDC	

**Operation diagram**

**For default factory sensor**

T<sub>v</sub> = Power-ON delay



Power supply	ON	
Target (Object)	Present	
Break output (N.C.)	ON	
Make output (N.O.)	ON	

**Response times**

Operating frequency (f)	≤ 1000 Hz	
Response times	≤ 500 μs	OFF-ON (t <sub>ON</sub> )
	≤ 500 μs	ON-OFF (t <sub>OFF</sub> )

**Indication**

Green LED	Yellow LED	Power	Function
<b>SIO and IO-Link mode</b>			
ON	ON	ON	ON (stable)* SSC1
ON	OFF	ON	OFF (stable)* SSC1
OFF	OFF	OFF	OFF (Not stable) SSC1
Flashing 1 Hz (10% or 90% duty-cycle)	-	ON	Connected via IO-Link
-	Flashing 10 Hz 50% duty-cycle	ON	Output short-circuit
-	Flashing 0.5...20 Hz 50% duty-cycle	ON	Timer triggered indication
<b>SIO mode only</b>			
-	Flashing 1 HZ ON 100 ms OFF 900 ms	ON	External teach by wire. Only for single point mode.
-	Flashing 1 HZ ON 900 ms OFF 100 ms	ON	Teach time window (3 - 6 sec).
-	Flashing 10 HZ ON 50 ms OFF 50 ms Flashing for 2 sec	ON	Teach time out (12 sec).
-	Flashing 2 HZ ON 250 ms OFF 250 ms Flashing for 2 sec	ON	Teach successful.
<b>IO-Link mode only</b>			
Flashing 1 HZ ON 900 ms OFF 100 ms	-	ON	Sensor is in IO-Link mode.
Flashing 2 Hz 50% duty-cycle		ON	Find my sensor

\*See operation diagram



**LED indication**

<b>LED indication selection</b>	<ul style="list-style-type: none"> <li>• LED indication inactive</li> <li>• LED indication active</li> <li>• Find my sensor</li> </ul> <p><b>Factory settings:</b> LED indication active</p>
---------------------------------	--

**Environmental**

<b>Ambient temperature</b>	-25° ... +60°C (-13° ... +140°F)	Operating <sup>1)</sup>
	-40° ... +85°C (-40° ... +185°F)	Storage <sup>1)</sup>
<b>Ambient humidity range</b>	35% ... 95%	Operating <sup>2)</sup>
	35% ... 95%	Storage <sup>2)</sup>
<b>Ambient light</b>	≤ 45 000 lux	@ 3000 ... 3200 °K
<b>Vibration</b>	10 ... 150 Hz, 1.0 mm/15 g	EN 60068-2-6
<b>Shock</b>	30 g <sub>n</sub> / 11 ms, 3 pos, 3 neg per axis	EN60068-2-27
<b>Drop test</b>	2 x 1 m and 100 x 0.5 m	EN 60068-2-31
<b>Rated insulation voltage (U<sub>i</sub>)</b>	50 VDC	
<b>Dielectric insulation voltage</b>	≥ 500 VAC rms	50/60 Hz for 1 min.
<b>Rated impulse withstand voltage</b>	> 1 kV (with 500 Ω)	1.2/50 μs
<b>Pollution degree</b>	3	IEC60664, 60664A; EN60947-1
<b>Overvoltage category</b>	III	IEC60664; EN60947-1
<b>Degree of protection</b>	IP67	IEC60539; EN60947-1
<b>NEMA Enclosure Types</b>	1	NEMA 250

<sup>1)</sup> Do not bend the cable in temperatures below -10°C

<sup>2)</sup> With no icing or condensation

**EMC**

<b>Electrostatic discharge immunity test</b>	± 8 kV @ air discharge or ± 4 kV @ contact discharge	IEC 61000-4-2; EN60947-1
<b>Electromagnetic field immunity</b>	10 V/m	IEC 61000-4-3; EN60947-1
<b>Fast transient immunity</b>	±2 kV / 5 kHz	IEC 61000-4-4; EN60947-1
<b>Wire-conducted noise</b>	10 Vrms	IEC 61000-4-3; EN60947-1
<b>Power frequency magnetic field immunity test</b>	Continuous: >30 A/m, 28 μ tesla Short-time: >300 A/m, 280 μ tesla	IEC 61000-4-8; EN60947-1



**Diagnostic parameters**

Function	Unit	Range
<b>Sensor Diagnostics</b>		
Frontend Failure	0	0 or 1
Memory Failure	0	0 or 1
<b>Temperature Diagnostics</b>		
Current temperature	[°C]	-50 ... +150
Maximum temperature - All time high	[°C]	-50 ... +150
Minimum temperature - All time low	[°C]	-50 ... +150
Maximum temperature - Since last power-up	[°C]	-50 ... +150
Minimum temperature - Since last power-up	[°C]	-50 ... +150
Minutes above Maximum Temperature	[min]	0 ... 2 147 483 647
Minutes below Minimum Temperature	[min]	0 ... 2 147 483 647
<b>Operating Diagnostic</b>		
Operating Hours	[h]	0 ... 2 147 483 647
Number of Power Cycles	[cycles]	0 ... 2 147 483 647
Detection counter SSC1	[cycles]	0 ... 2 147 483 647
Maintenance event counter	[cycles]	0 ... 2 147 483 647
Download counter	[counts]	0 ...65 536
Quality of Teach	-	0 ... 255%
Quality of Run	-	0 ... 255%
Excess gain		0 ... 255
Error Count	[counts]	0 ...65 536
Device Status	0 = Device is operating properly 1 = Maintenance required 2 = Out-of-specification 3 = Functional-Check 4 = Failure <b>Factory settings: 0</b>	

**Events Configuration**

Events	Factory default setting
Maintenance Event	Inactive
Temperature fault event	Inactive
Temperature over-run	Inactive
Temperature under-run	Inactive
Short circuit	Inactive

**Observation menu**

Process Data	Factory default setting
Analogue value	Analogue value Inactive
	Analogue value normal <b>Factory settings</b>
	Analogue value as Object Length
	Analogue value as Object Speed
	Analogue value as Counter value
Excess gain	Inactive
SO1, Switching output 1	Active
SO2, Switching output 2	Active
SSC1, Sensor switching channel 1	Inactive
SSC2, Sensor switching channel 2	Inactive
DA1, Dust alarm SSC1	Inactive
DA2, Dust alarm SSC2	Inactive
TA, Temperature alarm	Inactive
SC, Short circuit	Inactive
WDA1, Water drop alarm SSC1	Inactive
WDA2, Water drop alarm SSC2	Inactive
AFO1, Application functions output 1	Inactive

**Process data structure**

4 Bytes, Analogue value 16 ... 31 (16 bit)

Byte 0	31	30	29	28	27	26	25	24
	<b>MSB</b>	-	-	-	-	-	-	-
Byte 1	23	22	21	20	19	18	17	16
	-	-	-	-	-	-	-	<b>LSB</b>
Byte 2	15	14	13	12	11	10	9	8
	-	-	<b>SC</b>	<b>TA</b>	<b>DA2</b>	<b>DA1</b>	<b>SSC2</b>	<b>SSC1</b>
Byte 3	7	6	5	4	3	2	1	0
	<b>AFO1</b>	-	-	-	<b>WDA2</b>	<b>WDA1</b>	<b>SO2</b>	<b>SO1</b>

## Mechanics/electronics

### ▶ Connection

<b>Cable</b>	2 m, 4-wire 4 x 0.14 mm <sup>2</sup> , Ø = 3.3 mm, PVC, Black
<b>Plug</b>	M8, 4-pin, male

### ▶ Wiring

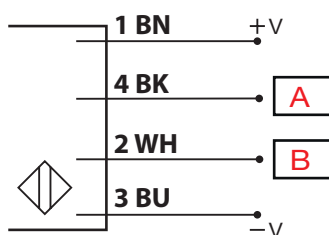

BN	BK	WH	BU	A	B
Brown	Black	White	Blue	OUT/IO-Link	IN/OUT

### ▶ Housing

<b>Body</b>	ABS	
<b>Front glass</b>	PMMA, Red	
<b>Trimmer shaft</b>	POM, Grey	
<b>Indication</b>	TPU, Transparent	
<b>Sealing</b>	NBR70	
<b>Dimensions</b>	10 x 30 x 20 mm	
<b>Weight</b>	≤ 50 g	Cable version
	≤ 20 g	Plug version

Dimensions

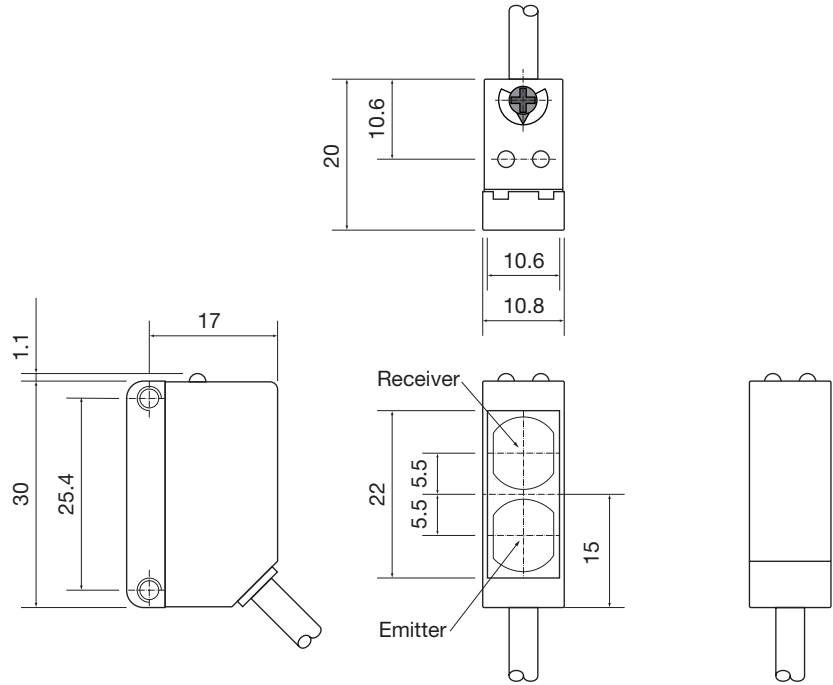

Fig. 4 Cable

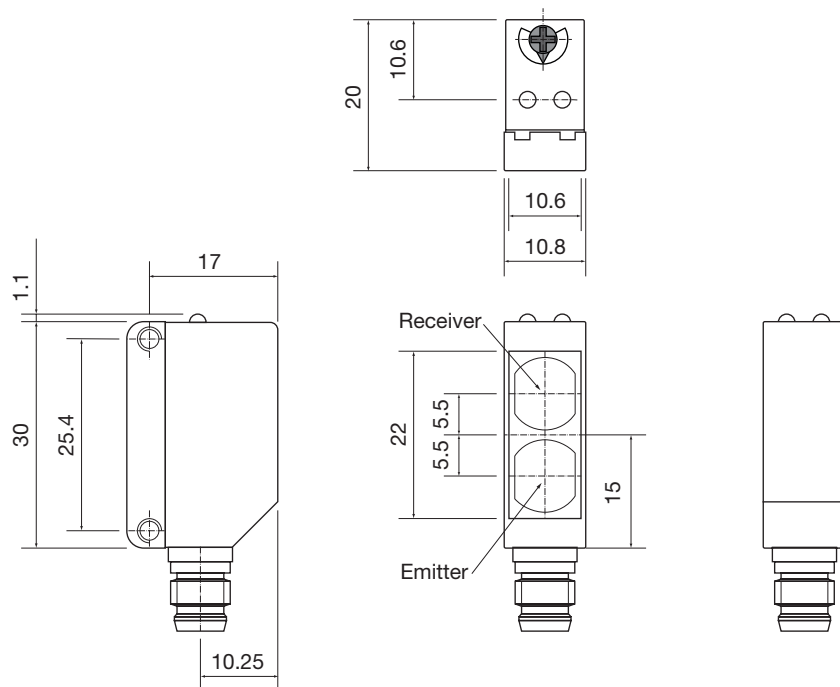



Fig. 5 Plug



## Compatibility and conformity

### Approvals and markings

<b>General reference</b>	Sensor designed according to EN60947-5-2	
<b>MTTF<sub>d</sub></b>	138.5 years	EN ISO 13849-1, SN 29500
<b>CE-marking</b>		
<b>Approvals</b>		

### IO-Link

<b>IO-Link revision</b>	1.1
<b>Transmission rate</b>	COM2 (38.4 kbaud)
<b>SDCI-Norm</b>	IEC 61131-9
<b>Profile</b>	Smart sensor profile 2nd edition, common profile
<b>Min. cycle time</b>	5 ms
<b>SIO mode</b>	Yes
<b>Min. master port class</b>	A (4-pin)
<b>Process data length</b>	32 bit



## Delivery contents and accessories



### ▶ Delivery contents

- Photoelectric switch: PD30CTPS50BPxxIO
- Screwdriver
- Packaging: Plastic bag

### ▶ Accessories

- Mounting bracket: APD30-MB1 or APD30-MB2 to be purchased separately
- Connector type: CON.54NF.. series to be purchased separately

### ▶ Further information

Information	Where to find it	QR
IO-Link manual	<a href="http://cga.pub/?063a58">http://cga.pub/?063a58</a>	
Mounting brackets	<a href="http://cga.pub/?6fa29a">http://cga.pub/?6fa29a</a>	
Connectors	<a href="http://cga.pub/?ed457b">http://cga.pub/?ed457b</a>	



COPYRIGHT ©2022  
 Content subject to change. Download the PDF: [www.gavazziautomation.com](http://www.gavazziautomation.com)