

Photoelectrics Diffuse-reflective Type PA18ALD04T.., AC, Metal-housing

CARLO GAVAZZI



- Range: 400 mm adjustable
- Modulated, infrared light
- Supply voltage: 20 to 250 VAC
- Output: 500 mA SCR
- Make or break switching function, LED indication
- High immunity to ambient light
- Heavy duty M18 metal housing, IP67
- Cable and plug versions



Product Description

The PA18ALD.. is a family of general purpose diffuse-reflective sensors in industrial standard 18 mm cylindrical nickel-plated brass housing for heavy duty applications. They are useful for simple applications where a basic

sensor provides adequate sensing performance. The sensors are easy to adjust with 270° single-turn potentiometer. The output is a 2-wire NO or NC thyristor (SCR) output.

Ordering Key PA18ALD04TOM6SA

Type	_____
Housing style	_____
Housing size	_____
Housing material	_____
Housing length	_____
Detection principle	_____
Sensing distance	_____
Output type	_____
Output configuration	_____
Connection type	_____
Adjustable	_____

Type Selection

Housing diameter	Rated operating dist. (S _n)	Ordering no. SCR/cable Make switching	Ordering no. SCR/plug Make switching	Ordering no. SCR/cable Break switching	Ordering no. SCR/plug Break switching
M18	400 mm	PA18ALD04TOSA	PA18ALD04TOM6SA	PA18ALD04TCSA	PA18ALD04TCM6SA

Note: Plugs to be ordered separately

Specifications

Rated operating dist. (S_n) Adjustable	Up to 400 mm, Ref. target Kodac test card 227, white, 90° reflectivity, 200 x 200 mm	Light type	Infrared, modulated synchronized
Sensitivity	270° single-turn potentiometer	Sensing angle	± 25° at 1/2 range
Temperature drift	0.4%/K	Ambient light	Max 10'000 lux
Hysteresis (H) (Differential travel)	3 to 20%,	Operating frequency (f)	20 Hz, light/dark ratio 1:2
Rated operational volt. (U_B)	20 to 250 VAC, 45 to 65 Hz	Response time OFF-ON (t _{ON}) ON-OFF (t _{OFF})	≤ 20 ms ≤ 30 ms
Output current (AC12, AC140) Continuous (I _a) Short-time (I)	≤ 500 mA ≤ 3A, max. 20 ms	Power ON delay (t_v)	Typ. 100 ms
Min. operational current (I_m)	10 mA	Indication function Output ON	Dark (NC) or light (NO) switching LED, yellow
OFF-state current (I_r)	Max < 5 mA, typ. 2.6 mA	Environment Overvoltage category Pollution degree Degree of protection	II (IEC 60664/60664A; 60947-1) 3 (IEC 60664/60664A; 60947-1) IP 67 (IEC 60529; 60947-1)
Voltage drop (U_d)	Max ≤ 10 V, typ. 7 VAC	Temperature Operating Storage	-20° to +60°C (-4° to 140°F) -30° to + 70°C (-22° to 158°F)
Protection	Transients	Vibration	10 to 150 Hz, 0.5 mm/- 7.5 g (IEC 60068-2-6)
Transient voltage	Max. 1 kV/0,5 J	Shock	2 x 1 m 100 x 0.5 m (IEC 60068-2-32)
Light source	GaAlAs LED, 880 nm		



Specifications (cont.)

Dielectric voltage	1600 VAC (IEC 60364-4-41)
Housing material	Nickel-plated brass Luran®, black
Body	Nickel-plated brass
Front	Luran®, black
Cable end	Polyester, black
Nuts	Nickel-plated brass
Connection	
Cable	Grey, 2 m, 2 x 0.5 mm ² , oilproof PVC,
Plug	M12 x 1
Cables for plug (-6)	CON.6A-.. series
Weight	
Cable version	150 g
Plug version	65 g
Approvals	UL, CSA
CE-marking	Yes

Dimensions

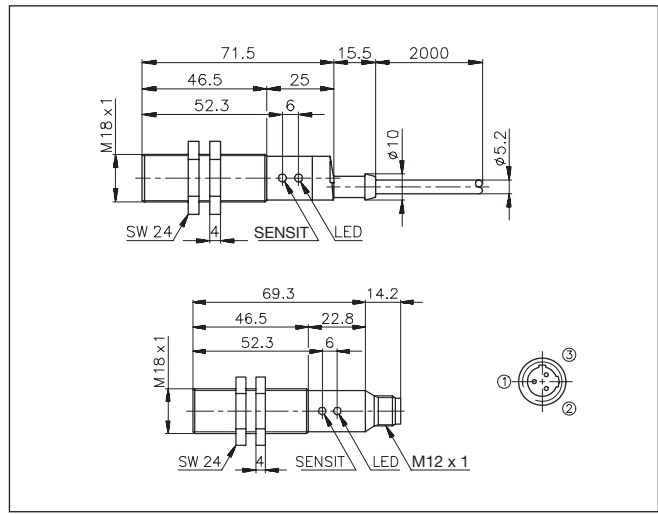

Operation Diagram

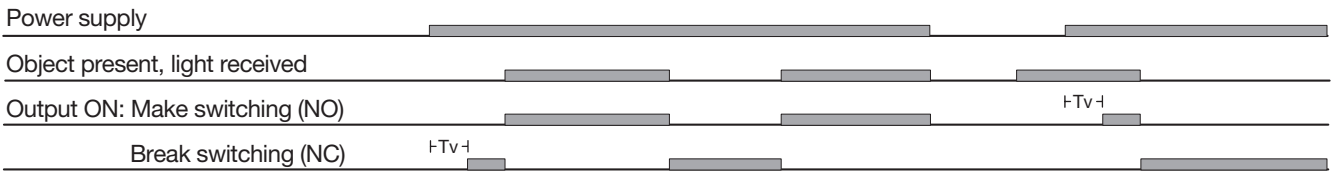

Wiring Diagrams

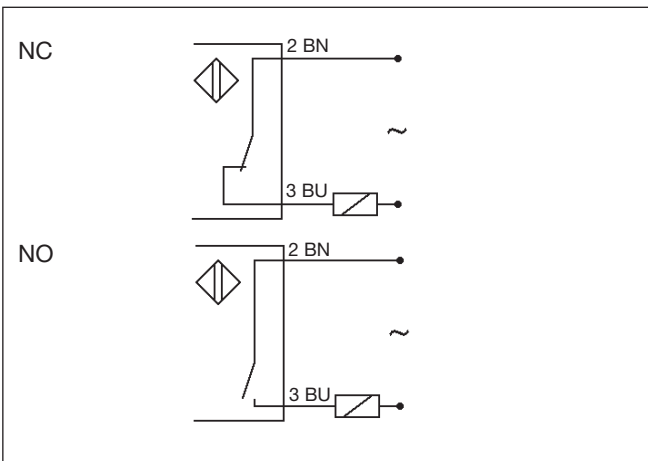

Detection Diagram

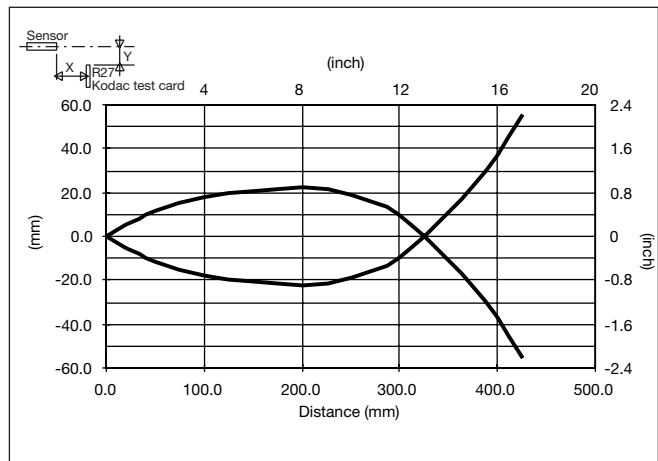



Delivery Contents

- Photoelectric switch: PA18ALD04..
- 2 nuts
- **Packaging:** plastic bag

Accessories

- Connector type CON.6A-.. series.
- Screw driver for adjustments: 77-000
- MB18A
- APA18-RAR

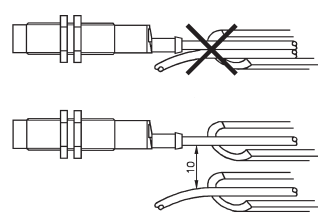
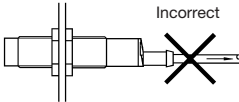
Installation Hints

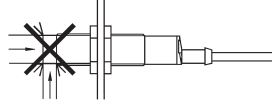
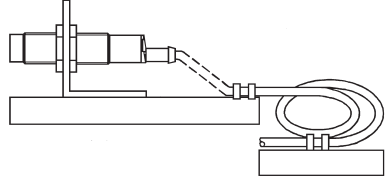
<p>To avoid interference from inductive voltage/current peaks, separate the prox. switch power cables from any other power cables, e.g. motor, contactor or solenoid cables</p> 	<p>Relief of cable strain</p> <p>Incorrect</p>  <p>Correct</p>  <p>The cable should not be pulled</p>	<p>Protection of the sensing face</p>  <p>A proximity switch should not serve as mechanical stop</p>	<p>Switch mounted on mobile carrier</p>  <p>Any repetitive flexing of the cable should be avoided</p>
---	---	--	--