



**Automatización Eléctrica**  
Especialistas en Automatización

At the end of this document you will find links to products related to this catalog. You can go directly to our shop by clicking [HERE](#). [HERE](#)

## Shield connection terminal block - SK 8 - 3025163

Please be informed that the data shown in this PDF Document is generated from our Online Catalog. Please find the complete data in the user's documentation. Our General Terms of Use for Downloads are valid (<http://phoenixcontact.com/download>)



Shield connection clamp, for shield on busbars, contact resistance < 1 mΩ

### Why buy this product

- Easy handling
- Spring-loaded, large-surface pressure plate
- Suitable for direct and busbar mounting
- Knurled screw

### Key Commercial Data

|              |   |
|--------------|---|
| Packing unit | 10 STK  |
| GTIN         | <br>4 017918 130299 |

### Technical data

#### General

|                                  |               |
|----------------------------------|---------------|
| Number of levels                 | 1             |
| Number of connections            | 1             |
| Cable diameter                   | 3 mm ... 8 mm |
| Color                            | silver        |
| Connection in acc. with standard | IEC / EN      |

#### Dimensions

|        |          |
|--------|----------|
| Length | 19.5 mm  |
| Width  | 12 mm    |
| Height | 48.70 mm |

#### Connection data

|                       |                  |
|-----------------------|------------------|
| Screw thread          | M4               |
| Tightening torque max | 0.6 Nm           |
| Connection method     | Screw connection |

#### Standards and Regulations

|                                  |          |
|----------------------------------|----------|
| Connection in acc. with standard | IEC / EN |
|----------------------------------|----------|

# Shield connection terminal block - SK 8 - 3025163

## Classifications

### eCl@ss

|            |          |
|------------|----------|
| eCl@ss 4.0 | 27141131 |
| eCl@ss 4.1 | 27141131 |
| eCl@ss 5.0 | 27141131 |
| eCl@ss 5.1 | 27141131 |
| eCl@ss 6.0 | 27141150 |
| eCl@ss 7.0 | 27141150 |
| eCl@ss 8.0 | 27141150 |

### ETIM

|          |          |
|----------|----------|
| ETIM 2.0 | EC000897 |
| ETIM 3.0 | EC000897 |
| ETIM 4.0 | EC002020 |
| ETIM 5.0 | EC002020 |

### UNSPSC

|               |          |
|---------------|----------|
| UNSPSC 6.01   | 30211811 |
| UNSPSC 7.0901 | 39121410 |
| UNSPSC 11     | 39121410 |
| UNSPSC 12.01  | 39121410 |
| UNSPSC 13.2   | 39121410 |

## Approvals

### Approvals

---

Approvals

EAC

---

Ex Approvals

---

Approvals submitted

---

### Approval details

|     |
|-----|
| EAC |
|-----|

## Drawings

# Shield connection terminal block - SK 8 - 3025163

Dimensional drawing

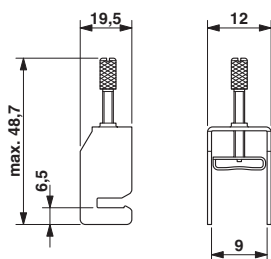

Dimensional drawing

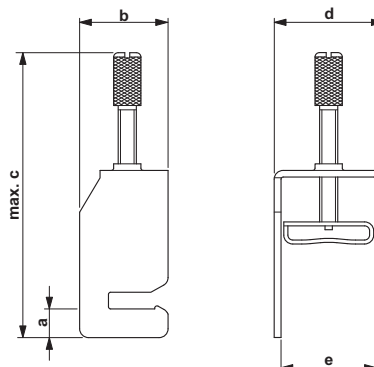

Diagram

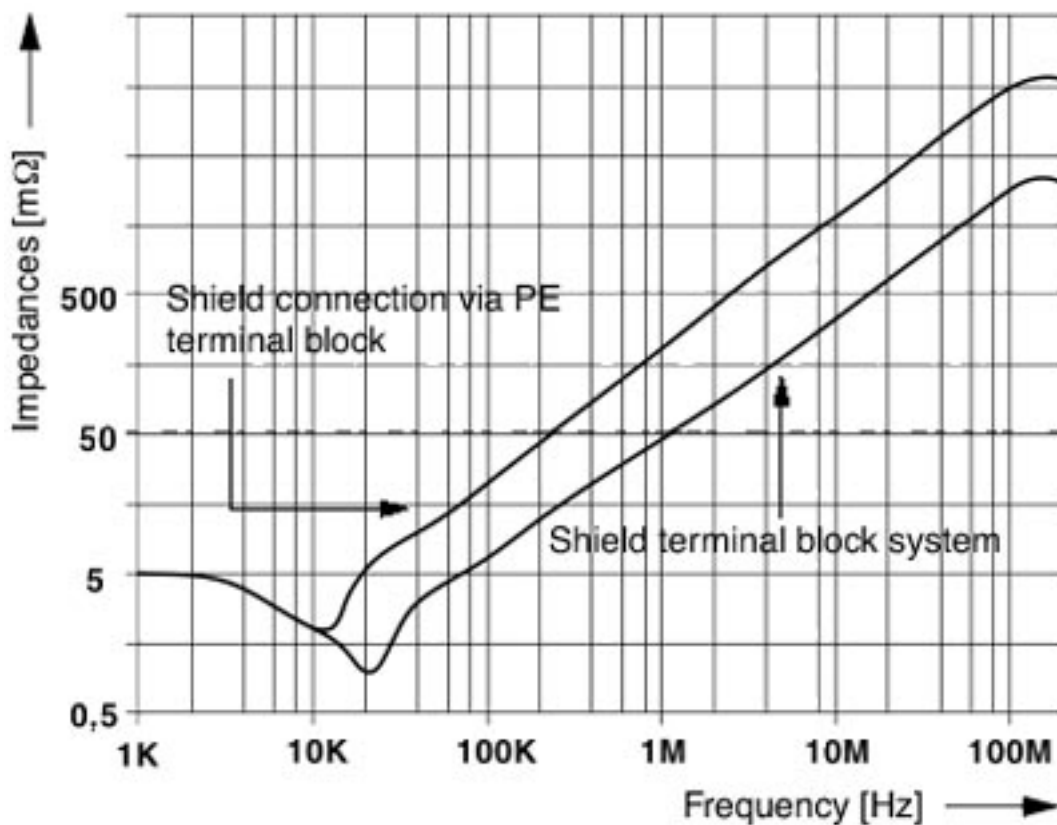

Phoenix Contact 2016 © - all rights reserved  
<http://www.phoenixcontact.com>

PHOENIX CONTACT GmbH & Co. KG  
Flachsmarktstr. 8  
32825 Blomberg  
Germany  
Tel. +49 5235 300  
Fax +49 5235 3 41200  
<http://www.phoenixcontact.com>



Below is a list of articles with direct links to our shop Electric Automation Network where you can see:

- Quote per purchase volume in real time.
- Online documentation and datasheets of all products.
- Estimated delivery time enquiry in real time.
- Logistics systems for the shipment of materials almost anywhere in the world.
- Purchasing management, order record and tracking of shipments.

To access the product, [click on the green button.](#)

| Product   | Code    | Reference | Product link               |
|---|---------|-----------|----------------------------|
| Shield connection clamp, for shield on busbars, contact resistance < 1 mΩ | 3025163 | SK 8      | <a href="#">Buy on EAN</a> |