



Automatización Eléctrica
Especialistas en Automatización

At the end of this document you will find links to products related to this catalog. You can go directly to our shop by clicking [HERE](#). [HERE](#)

Cover - EG 90-AG/ABS GN - 2907389

Please be informed that the data shown in this PDF Document is generated from our Online Catalog. Please find the complete data in the user's documentation. Our General Terms of Use for Downloads are valid (<http://phoenixcontact.com/download>)

Housing cover, closed



Illustration shows a fully mounted version of the electronic housing

Why buy this product

- Tool-free mounting
- Fast snap-on mounting on symmetrical DIN rails according to EN 60715
- Practical and easy-to-wire conductor connection using extra finely stranded sturdy screw terminal blocks up to 2.5 mm²
- Optimum accommodation of electronic components with graded pitches with a design width of 22.5 mm, 45 mm, 67.5 mm, and 90 mm
- Functional and industry-oriented housing technology
- Date of manufacture and material and part identification embossed on the housing (recyclability)
- Shock and contamination-proof accommodation of electronic components (IP40 housing, IP20 terminal blocks)

Key Commercial Data

Packing unit	10 STK
GTIN	 4 017918 131494

Technical data

General

Housing type	Component housing
Color	green

Dimensions

Constructional height	17.5 mm
Width	90 mm

Technical data

Number of positions	34
---------------------	----

Classifications

eCl@ss

eCl@ss 4.0	27180401
------------	----------

Cover - EG 90-AG/ABS GN - 2907389

Classifications

eCl@ss

eCl@ss 4.1	27180401
eCl@ss 5.0	27180506
eCl@ss 5.1	27180506
eCl@ss 6.0	27180802
eCl@ss 7.0	27182702
eCl@ss 8.0	27182702
eCl@ss 9.0	27182702

ETIM

ETIM 2.0	EC001031
ETIM 3.0	EC001031
ETIM 4.0	EC001031
ETIM 5.0	EC001031

UNSPSC

UNSPSC 6.01	31261501
UNSPSC 7.0901	31261501
UNSPSC 11	31261501
UNSPSC 12.01	31261501
UNSPSC 13.2	31261501

Approvals

Approvals

Approvals

UL Recognized

Ex Approvals

Approvals submitted

Approval details

UL Recognized

Drawings

Cover - EG 90-AG/ABS GN - 2907389

Dimensional drawing

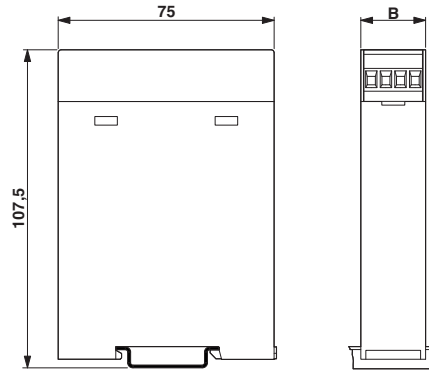

Explosion drawing

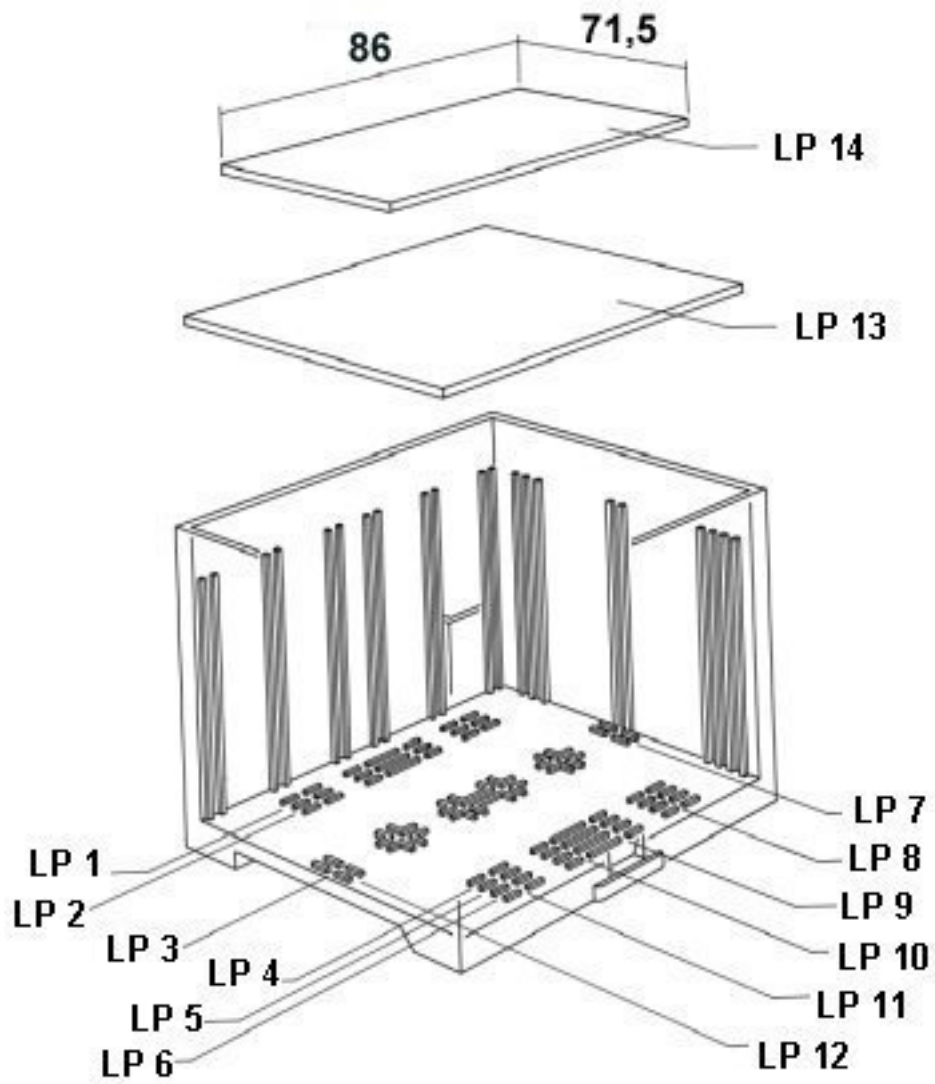

Cover - EG 90-AG/ABS GN - 2907389

Explosion drawing

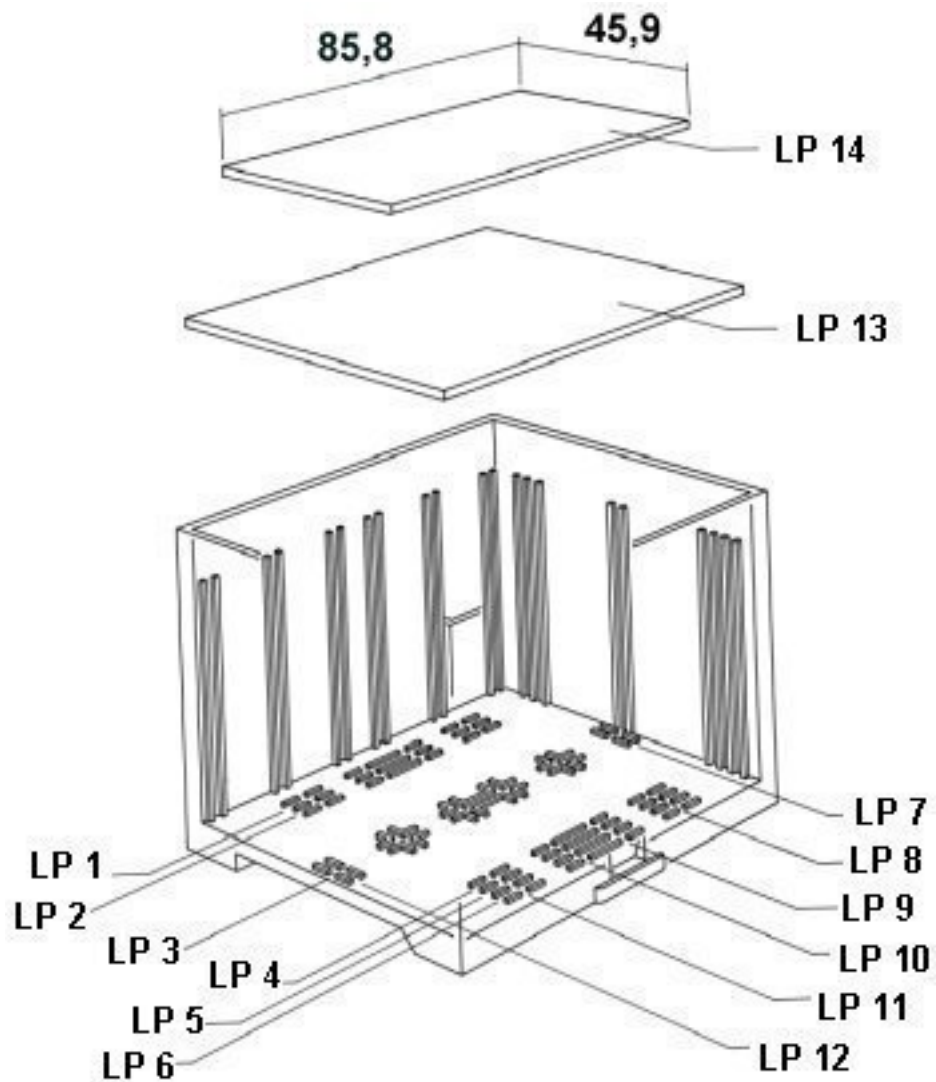

valid for PCB 14

Cover - EG 90-AG/ABS GN - 2907389

Dimensional drawing

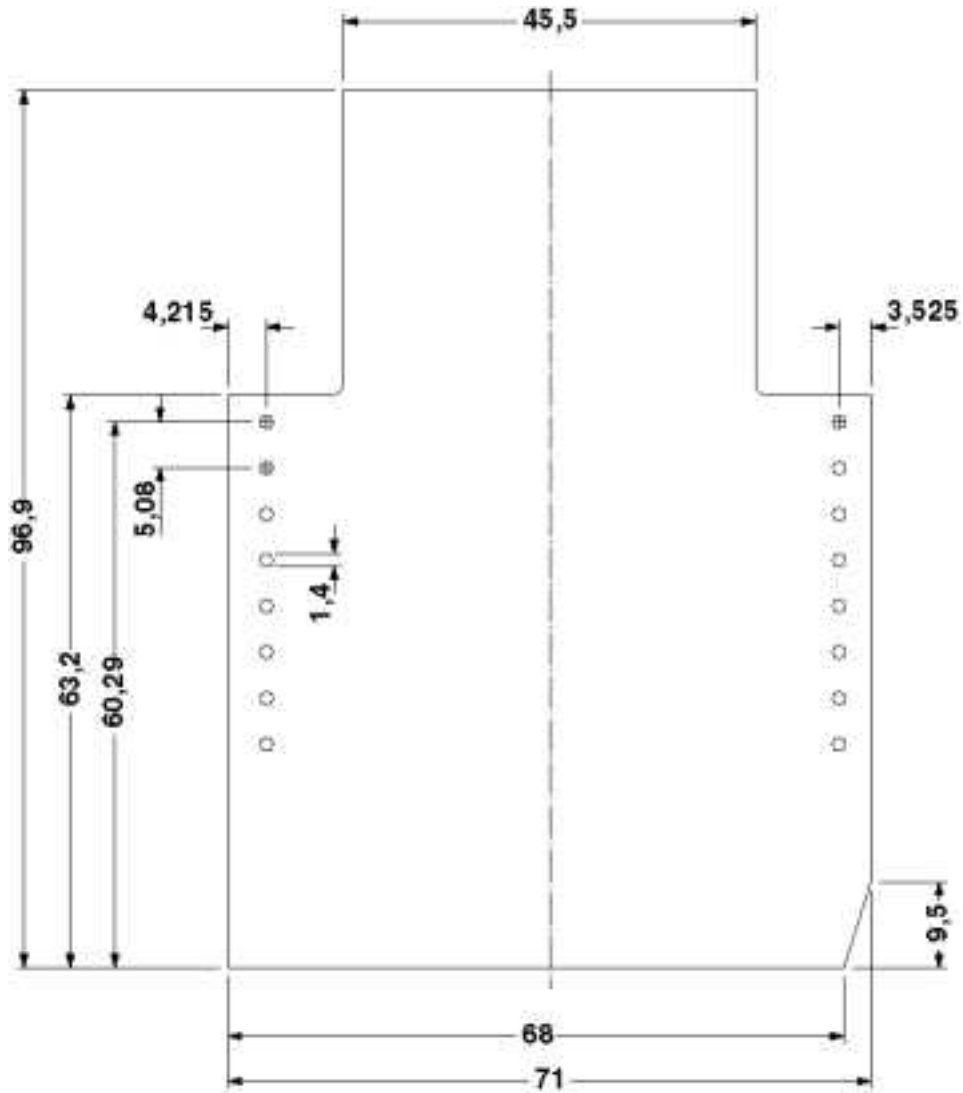

Component mounting side, if the double-level upper part is used

Cover - EG 90-AG/ABS GN - 2907389

Dimensional drawing

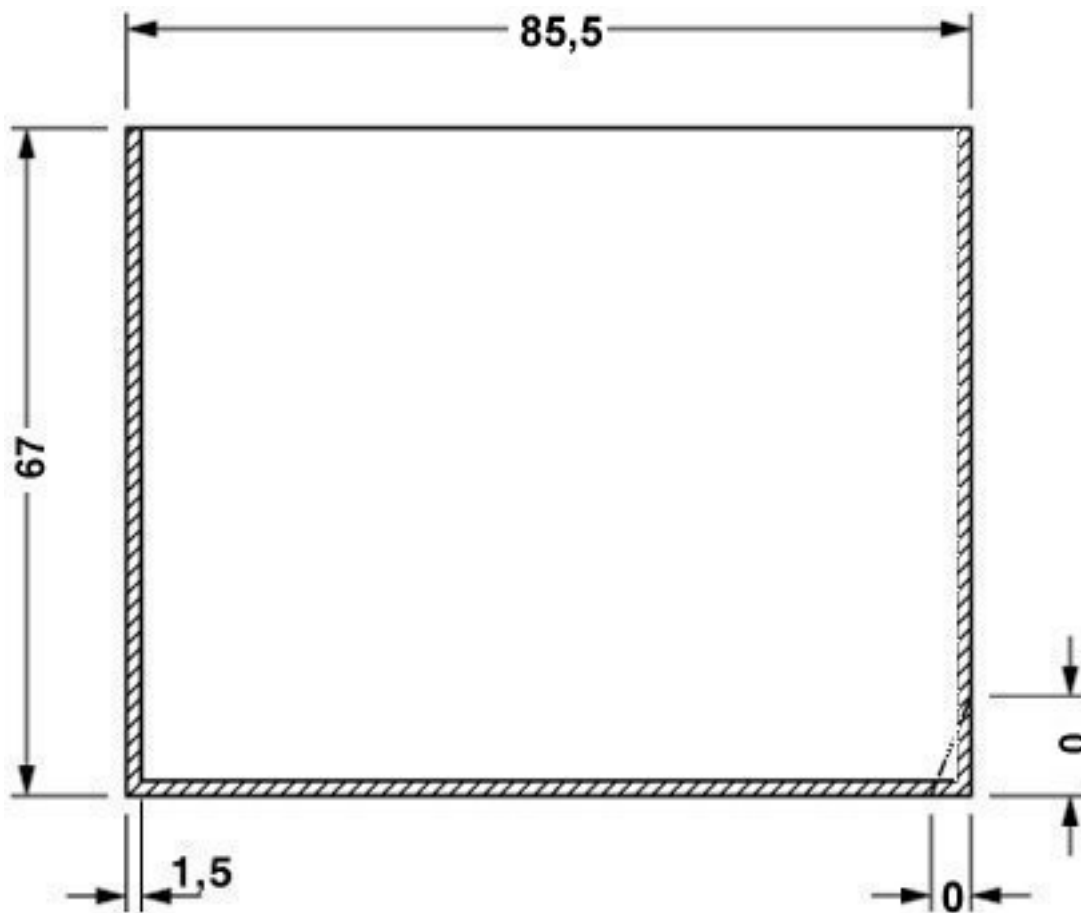

valid for PCB 1; 2; 3; 4; 5 und 6, see explosion drawing

Cover - EG 90-AG/ABS GN - 2907389

Dimensional drawing

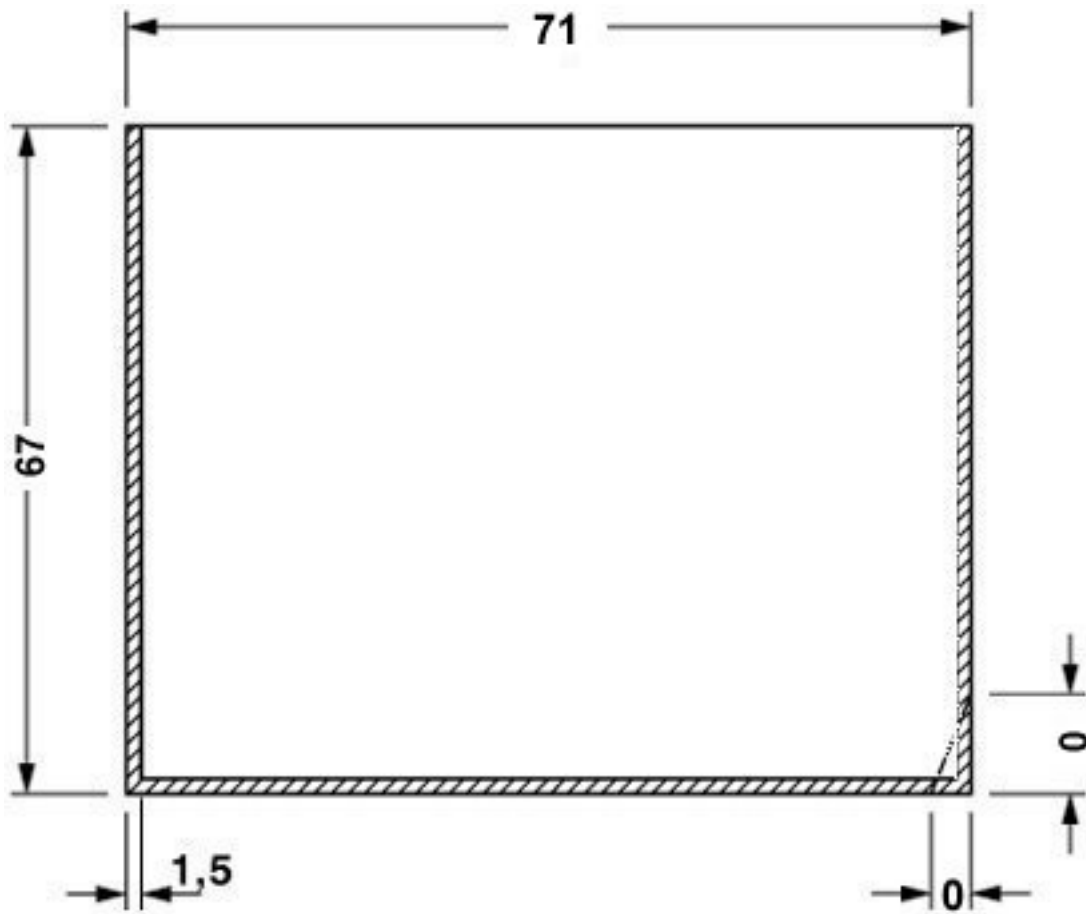

valid for PCB 7; 8; 11 and 12, see explosion drawing

Cover - EG 90-AG/ABS GN - 2907389

Dimensional drawing

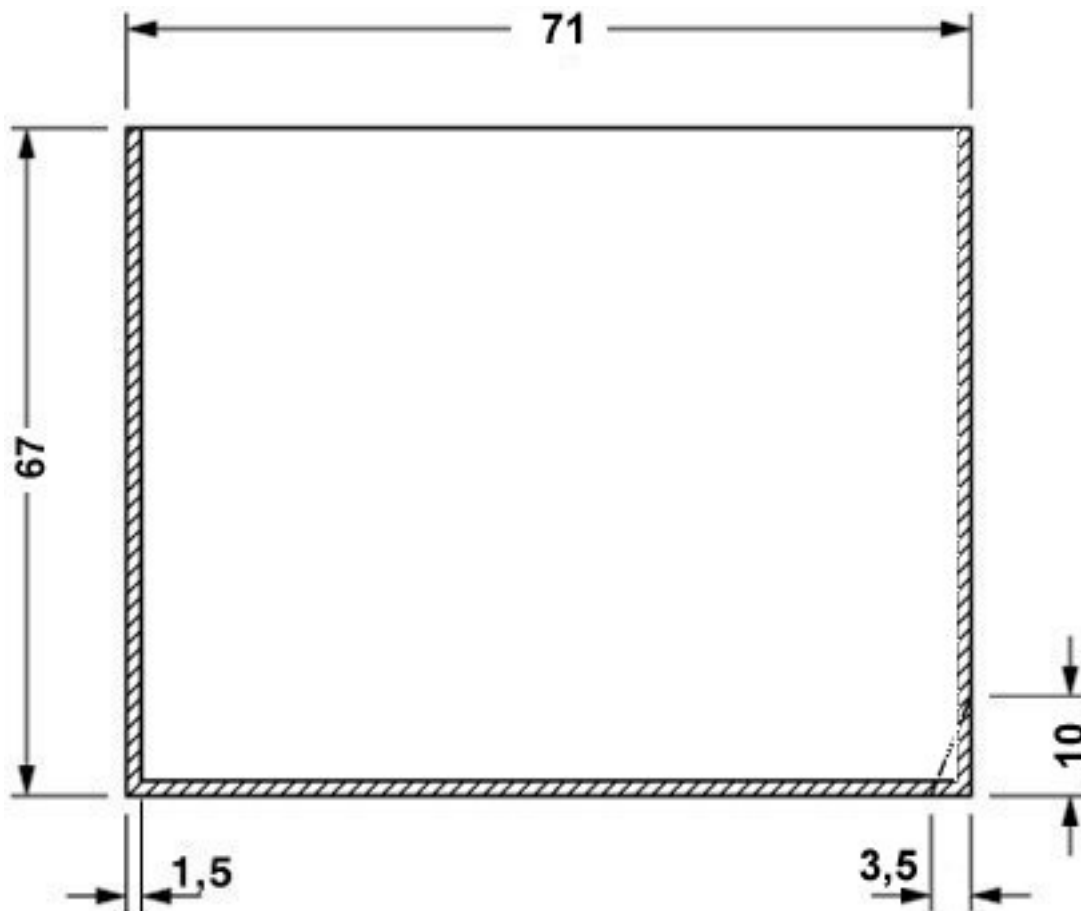

valid for PCB 9 and 10, see explosion drawing

Phoenix Contact 2016 © - all rights reserved
<http://www.phoenixcontact.com>

PHOENIX CONTACT GmbH & Co. KG
Flachsmarktstr. 8
32825 Blomberg
Germany
Tel. +49 5235 300
Fax +49 5235 3 41200
<http://www.phoenixcontact.com>



Below is a list of articles with direct links to our shop Electric Automation Network where you can see:

- Quote per purchase volume in real time.
- Online documentation and datasheets of all products.
- Estimated delivery time enquiry in real time.
- Logistics systems for the shipment of materials almost anywhere in the world.
- Purchasing management, order record and tracking of shipments.

To access the product, [click on the green button.](#)

Product	Code	Reference	Product link
Housing cover, closed	2907389	EG 90-AG/ABS GN	Buy on EAN