



**Automatización Eléctrica**  
Especialistas en Automatización

At the end of this document you will find links to products related to this catalog. You can go directly to our shop by clicking HERE. [HERE](#)

## Interface module - DFLK-D25 SUB/F/FKCT - 2903067

Please be informed that the data shown in this PDF Document is generated from our Online Catalog. Please find the complete data in the user's documentation. Our General Terms of Use for Downloads are valid (<http://phoenixcontact.com/download>)



The VARIOFACE feed-through module implements a 1:1 connection between plug-in push-in spring-cage connection terminal blocks and a D-SUB miniature socket strip (number of positions: 25). A separate ground tap is available.

### Key Commercial Data

Packing unit	1 STK
GTIN	 4 046356 709460

### Technical data

#### Dimensions

Width	36.5 mm
Height	83.4 mm
Depth	46 mm

#### Ambient conditions

Ambient temperature (operation)	-20 °C ... 50 °C
Ambient temperature (storage/transport)	-20 °C ... 70 °C

#### General

Max. perm. operating voltage	125 V AC/DC
Max. perm. current (per branch)	2.5 A
Max. permissible current (all branches)	50 A (at T <sub>A</sub> = 50 °C)
Number of positions	25
Mounting position	any
Assembly instructions	In rows with zero spacing
Degree of protection	IP20
Standards/regulations	DIN EN 50178
	IEC 60664
	IEC 62103
Rated insulation voltage	125 V
Rated surge voltage	1.2 kV (Functional insulation)
Degree of pollution	2
Overvoltage category	II

# Interface module - DFLK-D25 SUB/F/FKCT - 2903067

## Technical data

### Connection data for connection 1

Connection name	Field level
Connection method	Plug-in push-in spring-cage connection
Stripping length	10 mm
Conductor cross section solid	0.2 mm <sup>2</sup> ... 2.5 mm <sup>2</sup>
Conductor cross section flexible	0.2 mm <sup>2</sup> ... 2.5 mm <sup>2</sup>
Conductor cross section AWG	24 ... 12

### Connection data for connection 2

Connection name	Controller level
Connection method	D-SUB socket strip
Number of positions	25

### Standards and Regulations

Connection in acc. with standard	CUL
Standards/regulations	DIN EN 50178
	IEC 60664
	IEC 62103
Degree of pollution	2
Overvoltage category	II

## Classifications

### eCl@ss

eCl@ss 4.0	27250313
eCl@ss 4.1	27250313
eCl@ss 5.0	27250313
eCl@ss 5.1	27250313
eCl@ss 6.0	27242608
eCl@ss 7.0	27141152
eCl@ss 8.0	27141152

### ETIM

ETIM 2.0	EC001434
ETIM 3.0	EC001604
ETIM 4.0	EC001604
ETIM 5.0	EC002780

### UNSPSC

UNSPSC 6.01	30211824
UNSPSC 7.0901	39121421
UNSPSC 11	39121421
UNSPSC 12.01	39121421

# Interface module - DFLK-D25 SUB/F/FKCT - 2903067

## Classifications

### UNSPSC

UNSPSC 13.2	39121421
-------------	----------

## Approvals

### Approvals

### Approvals

UL Recognized / cUL Recognized / EAC / cULus Recognized

### Ex Approvals

### Approvals submitted

## Approval details

UL Recognized	
mm <sup>2</sup> /AWG/kcmil	30-12
Nominal current I <sub>N</sub>	1 A
Nominal voltage U <sub>N</sub>	125 V

cUL Recognized	
mm <sup>2</sup> /AWG/kcmil	30-12
Nominal current I <sub>N</sub>	1 A
Nominal voltage U <sub>N</sub>	125 V

EAC
-----

cULus Recognized
------------------

## Drawings

## Interface module - DFLK-D25 SUB/F/FKCT - 2903067

Dimensional drawing

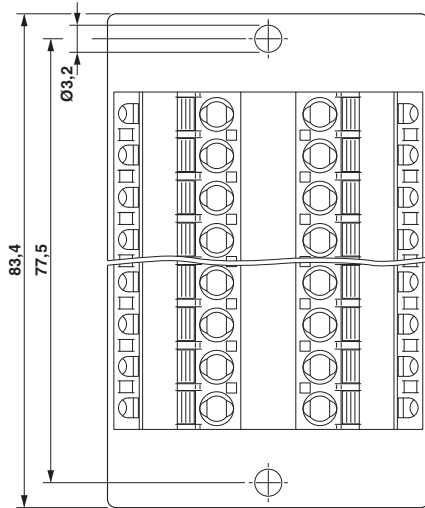

Dimensional drawing

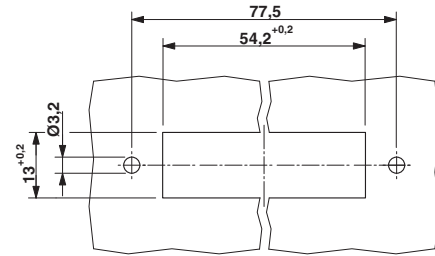

Dimensional drawing

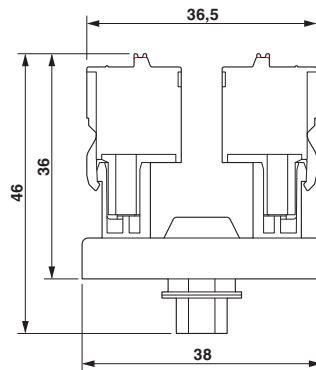

Phoenix Contact 2016 © - all rights reserved  
<http://www.phoenixcontact.com>

PHOENIX CONTACT GmbH & Co. KG  
Flachsmarktstr. 8  
32825 Blomberg  
Germany  
Tel. +49 5235 300  
Fax +49 5235 3 41200  
<http://www.phoenixcontact.com>



Below is a list of articles with direct links to our shop Electric Automation Network where you can see:

- Quote per purchase volume in real time.
- Online documentation and datasheets of all products.
- Estimated delivery time enquiry in real time.
- Logistics systems for the shipment of materials almost anywhere in the world.
- Purchasing management, order record and tracking of shipments.

To access the product, [click on the green button.](#)

Product	Code	Reference	Product link
The VARIOFACE feed-through module implements a 1:1 connection between plug-in push-in spring-cage connection terminal blocks and a D-SUB miniature socket strip (number of positions: 25). A separate ground tap is available.	2903067	DFLK-D25 SUB/F/FKCT	<a href="#">Buy on EAN</a>