



**Automatización Eléctrica**  
Especialistas en Automatización

At the end of this document you will find links to products related to this catalog. You can go directly to our shop by clicking HERE. [HERE](#)

## Round cable - VIP-CAB-FLK14/AXIO/0,14/1,5M - 2901606

Please be informed that the data shown in this PDF Document is generated from our Online Catalog. Please find the complete data in the user's documentation. Our General Terms of Use for Downloads are valid (<http://phoenixcontact.com/download>)

System cable with a 14-pos. molded socket strip (90° outlet) and one open end with 8 wires for connection to Axioline realtime I/O. At the open end, the wires are labeled 1 to 8 and are fitted with ferrules, cable length: 1.5 m.



### Why buy this product

- 8 pre-assembled open ends, for connection to the Axioline realtime I/O system
- 14-pos. connector, molded
- Labeling field on plug
- 1:1 connection
- Transmission of groups of 8 channels

### Key Commercial Data

Packing unit	1 STK
GTIN	 4 046356 616492

### Technical data

#### General

Nominal voltage $U_N$	< 50 V AC
	60 V DC
Max. current carrying capacity per path	1 A
Max. conductor resistance	0.16 $\Omega$ /m
Length of cable	1.5 m
Single wire, cross section	0.14 mm <sup>2</sup>
Single wire, cross section [AWG]	26
Conductor construction: Number of litz wires:	7
Single wire, material	Cu tin-plated
External diameter	6.4 mm
Cable, preassembly	Insulation displacement, IEC 60352-4/DIN EN 60352-4
Shielding	no

#### Environmental conditions

Ambient temperature (operation)	-20 °C ... 50 °C
Ambient temperature (storage/transport)	-20 °C ... 70 °C

# Round cable - VIP-CAB-FLK14/AXIO/0,14/1,5M - 2901606

## Technical data

### Environmental conditions

Flame resistance	IEC 60332-1
	DIN VDE 0482 Part 332-1

### Connector, module side

Connection method	IDC/FLK socket strip (2.54 mm)
Number of connections	1
Number of positions	14
Conductor cross section AWG	26

### Connector, controller side

Connection method	Open end
Number of positions	8

### Supported controller

Controller	PHOENIX CONTACT Axioline
- suitable I/O card	AXL DI 16/4
	AXL DI 32/1
	AXL DO 16/3
	AXL DO 32/1

### Standards and Regulations

Flame resistance	IEC 60332-1
	DIN VDE 0482 Part 332-1

## Classifications

### eCl@ss

eCl@ss 4.0	27250315
eCl@ss 4.1	27250315
eCl@ss 5.0	27249290
eCl@ss 5.1	27061801
eCl@ss 6.0	27061801
eCl@ss 7.0	27061801
eCl@ss 8.0	27249205

### ETIM

ETIM 3.0	EC000830
ETIM 4.0	EC002599
ETIM 5.0	EC000237

### UNSPSC

UNSPSC 6.01	26121620
UNSPSC 7.0901	26121620

# Round cable - VIP-CAB-FLK14/AXIO/0,14/1,5M - 2901606

## Classifications

### UNSPSC

UNSPSC 11	26121620
UNSPSC 12.01	26121620
UNSPSC 13.2	26121620

## Approvals

### Approvals

---

Approvals

EAC / EAC

---

Ex Approvals

---

Approvals submitted

---

### Approval details

EAC

EAC

## Drawings

Dimensional drawing

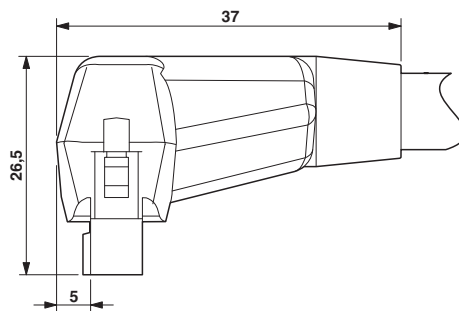

Phoenix Contact 2016 © - all rights reserved  
<http://www.phoenixcontact.com>

PHOENIX CONTACT GmbH & Co. KG  
Flachsmarktstr. 8  
32825 Blomberg  
Germany  
Tel. +49 5235 300  
Fax +49 5235 3 41200  
<http://www.phoenixcontact.com>



Below is a list of articles with direct links to our shop Electric Automation Network where you can see:

- Quote per purchase volume in real time.
- Online documentation and datasheets of all products.
- Estimated delivery time enquiry in real time.
- Logistics systems for the shipment of materials almost anywhere in the world.
- Purchasing management, order record and tracking of shipments.

To access the product, [click on the green button.](#)

Product	Code	Reference	Product link
System cable with a 14-pos. molded socket strip (90° outlet) and one open end with 8 wires for connection to Axioline realtime I/O. At the open end, the wires are labeled 1 to 8 and are fitted with ferrules, cable length: 1.5 m.	2901606	VIP-CAB-FLK14/ AXIO/0,14/1,5M	<a href="#">Buy on EAN</a>