



Automatización Eléctrica
Especialistas en Automatización

At the end of this document you will find links to products related to this catalog. You can go directly to our shop by clicking [HERE](#). [HERE](#)

Type 2 surge protection plug - VAL-US 60 ST - 2800738

Please be informed that the data shown in this PDF Document is generated from our Online Catalog. Please find the complete data in the user's documentation. Our General Terms of Use for Downloads are valid (<http://phoenixcontact.com/download>)



Surge protection plug type 2 with high-capacity varistor for VAL-MS base element, thermal monitoring, visual fault warning. Design: 60 V AC

The figure shows the VAL-US 347 ST version



Key Commercial Data

Packing unit	10 STK
GTIN	 4 046356 643795

Technical data

Dimensions

Height	52.4 mm
Width	17.5 mm
Depth	55.3 mm
Horizontal pitch	1 Div.

Ambient conditions

Degree of protection	IP20
Ambient temperature (operation)	-40 °C ... 80 °C
Ambient temperature (storage/transport)	-40 °C ... 80 °C
Altitude	≤ 2000 m (amsl (above mean sea level))
Permissible humidity (operation)	5 % ... 95 %
Shock (operation)	25g
Vibration (operation)	5g

General

Standards/specifications	IEC 61643-11 2011
	EN 61643-11 2012

Type 2 surge protection plug - VAL-US 60 ST - 2800738

Technical data

General

IEC test classification	II
	T2
EN type	T2
SPD design	Voltage-limiting type
Mode of protection	L-PEN
Mounting type	On base element
Color	black
Housing material	PA 6.6
Degree of pollution	2
Flammability rating according to UL 94	V-0
Type	Male
Number of positions	1
Arrester can be tested with CHECKMASTER from software version:	From SW rev. 1.10
Surge protection fault message	optical

Protective circuit

Nominal voltage U_N	60 V AC (TN)
	60 V DC
	-48 V DC (RRH)
Nominal frequency f_N	60 Hz (50 Hz)
Maximum continuous voltage U_C	75 V AC
Residual current I_{PE}	≤ 0.45 mA
Standby power consumption P_C	≤ 35 mVA
Nominal discharge current I_n (8/20) μ s	15 kA
Maximum discharge current I_{max} (8/20) μ s	40 kA
Short-circuit current rating I_{SCCR}	25 kA
Voltage protection level U_p	≤ 0.55 kV
Residual voltage U_{res}	≤ 0.55 kV (at I_n)
	≤ 0.425 kV (at 10 kA)
	≤ 0.325 kV (at 5 kA)
	≤ 0.275 kV (at 3 kA)
TOV behavior at U_T	100 V AC (5 s / withstand mode)
Response time t_A	≤ 25 ns
Max. backup fuse with branch wiring	125 A AC (gG)
	50 A DC (gG)

Connection data

Connection method	VALVETRAB plug-in system
-------------------	--------------------------

UL specifications

SPD Type	4 (for Type 2 applications)
Maximum continuous operating voltage MCOV (L-N)	75 V AC

Type 2 surge protection plug - VAL-US 60 ST - 2800738

Technical data

UL specifications

Maximum continuous operating voltage MCOV (L+) - (L-)	100 V DC
Maximum continuous operating voltage MCOV (L+/L-) - G	100 V DC
Nom. voltage	60 V AC
Nominal voltage	60 V DC
Mode of protection	L-N
	(L+) - (L-)
	(L+/L-) - G
Power distribution system	1
Nominal frequency	50/60 Hz
Voltage protection rating VPR (L-N)	0.5 kV
Voltage protection rating VPR (L+) - (L-)	0.33 kV
Voltage protection rating VPR (L+/L-) -G	0.33 kV
Nominal discharge current I _n (L-N)	10 kA
Nominal discharge current I _n (L+) - (L-)	10 kA
Nominal discharge current I _n (L+/L-) - G	10 kA

Classifications

eCl@ss

eCl@ss 4.0	27140201
eCl@ss 4.1	27130801
eCl@ss 5.0	27130801
eCl@ss 5.1	27130801
eCl@ss 6.0	27130803
eCl@ss 7.0	27130803
eCl@ss 8.0	27130805

ETIM

ETIM 3.0	EC000472
ETIM 4.0	EC000472
ETIM 5.0	EC000941

UNSPSC

UNSPSC 6.01	30212010
UNSPSC 7.0901	39121610
UNSPSC 11	39121610
UNSPSC 12.01	39121610
UNSPSC 13.2	39121620

Approvals

Approvals

Type 2 surge protection plug - VAL-US 60 ST - 2800738

Approvals

Approvals

UL Recognized / cUL Recognized / CSA / EAC / cULus Recognized

Ex Approvals

Approvals submitted

Approval details

UL Recognized

cUL Recognized

CSA

EAC

cULus Recognized

Drawings

Dimensional drawing

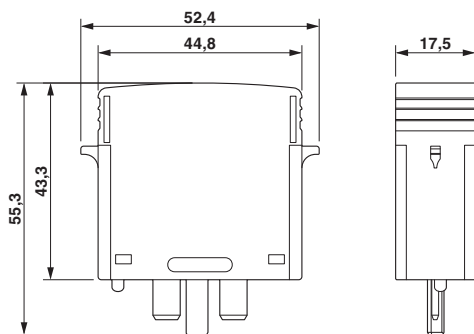

Circuit diagram



Phoenix Contact 2016 © - all rights reserved
<http://www.phoenixcontact.com>

PHOENIX CONTACT GmbH & Co. KG
Flachmarktstr. 8
32825 Blomberg
Germany
Tel. +49 5235 300
Fax +49 5235 3 41200
<http://www.phoenixcontact.com>



Automatización Eléctrica
Especialistas en Automatización

Below is a list of articles with direct links to our shop Electric Automation Network where you can see:

- Quote per purchase volume in real time.
- Online documentation and datasheets of all products.
- Estimated delivery time enquiry in real time.
- Logistics systems for the shipment of materials almost anywhere in the world.
- Purchasing management, order record and tracking of shipments.

To access the product, [click on the green button.](#)

Product	Code	Reference	Product link
Surge protection plug type 2 with high-capacity varistor for VAL-MS base element, thermal monitoring, visual fault warning. Design: 60 V AC	2800738	VAL-US 60 ST	Buy on EAN