



Automatización Eléctrica
Especialistas en Automatización

At the end of this document you will find links to products related to this catalog. You can go directly to our shop by clicking [HERE](#). [HERE](#)

Electronic housing - UEGM-MSTB - 2781453

Please be informed that the data shown in this PDF Document is generated from our Online Catalog. Please find the complete data in the user's documentation. Our General Terms of Use for Downloads are valid (<http://phoenixcontact.com/download>)



Electronic housing, for PCB insertion, with 12-pos. Combicon pin strip

Why buy this product

- Efficient assembly thanks to overlapping housing parts
- Unused LED cutouts can be sealed with UEGM MSTB-BS filler plugs
- Plug-in connection can be keyed with CP-MSTB/CR-MSTB to prevent incorrect polarity
- Can be snapped onto standard NS 35/7,5 and NS 35/15 DIN rails
- Integration of 3 mm LEDs (max. leg length of 29 mm)
- The MSTB-BL keying tab can be used to cover individual contact pins in order to form sections on the pin strip

Key Commercial Data

Packing unit	10 STK
GTIN	 4 017918 068967

Technical data

General

Housing type	Complete housing
Housing material	Polyamide (PA 6.6)
Color	green

Ambient conditions

Ambient temperature (operation)	-40 °C ... 105 °C
---------------------------------	-------------------

Dimensions

Length	79 mm
Constructional height	90.5 mm
Width	25 mm

Technical data

Flammability rating according to UL 94	V0
Power dissipation without gap	4 W
Power dissipation with 20 mm gap	10 W

Electronic housing - UEGM-MSTB - 2781453

Technical data

Technical data

Number of positions	12
---------------------	----

Standards and Regulations

Flammability rating according to UL 94	V0
--	----

Classifications

eCl@ss

eCl@ss 4.0	27180401
eCl@ss 4.1	27180401
eCl@ss 5.0	27180506
eCl@ss 5.1	27180506
eCl@ss 6.0	27180802
eCl@ss 7.0	27182702
eCl@ss 8.0	27182702
eCl@ss 9.0	27182702

ETIM

ETIM 2.0	EC001031
ETIM 3.0	EC001031
ETIM 4.0	EC001031
ETIM 5.0	EC001031

UNSPSC

UNSPSC 6.01	31261501
UNSPSC 7.0901	31261501
UNSPSC 11	31261501
UNSPSC 12.01	31261501
UNSPSC 13.2	31261501

Approvals

Approvals

Approvals

UL Recognized / EAC

Ex Approvals

Approvals submitted

Electronic housing - UEGM-MSTB - 2781453

Approvals

Approval details

UL Recognized

EAC

Drawings

Explosion drawing

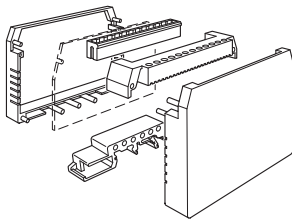

Dimensional drawing

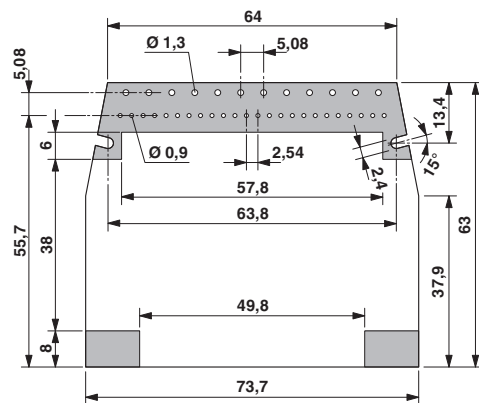

Soldering side of PCB layout
1 = Overall component area

Dimensional drawing

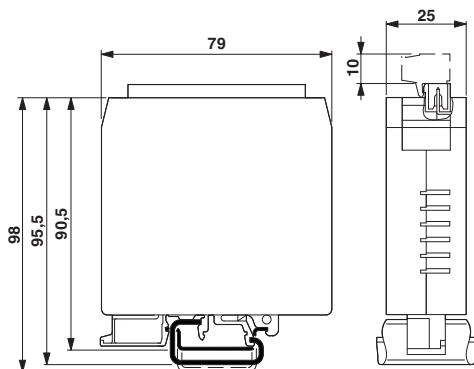

Dimensional drawing

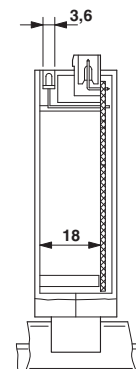

Maximum height of the components on the PCB

Phoenix Contact 2016 © - all rights reserved
<http://www.phoenixcontact.com>

PHOENIX CONTACT GmbH & Co. KG
Flachmarktstr. 8
32825 Blomberg
Germany
Tel. +49 5235 300
Fax +49 5235 3 41200
<http://www.phoenixcontact.com>



Below is a list of articles with direct links to our shop Electric Automation Network where you can see:

- Quote per purchase volume in real time.
- Online documentation and datasheets of all products.
- Estimated delivery time enquiry in real time.
- Logistics systems for the shipment of materials almost anywhere in the world.
- Purchasing management, order record and tracking of shipments.

To access the product, [click on the green button.](#)

Product	Code	Reference	Product link
Electronic housing, for PCB insertion, with 12-pos. Combicon pin strip	2781453	UEGM-MSTB	Buy on EAN