



Automatización Eléctrica
Especialistas en Automatización

At the end of this document you will find links to products related to this catalog. You can go directly to our shop by clicking [HERE](#). [HERE](#)

Distributed I/O device - RL PN 24-2 DI 16 2TX - 2773665

Please be informed that the data shown in this PDF Document is generated from our Online Catalog. Please find the complete data in the user's documentation. Our General Terms of Use for Downloads are valid (<http://phoenixcontact.com/download>)



Digital input device for PROFINET, 100Base-TX, fast startup, supported protocols: SNMPv2, TFTP, LLDP and PDev for topology detection, 16 inputs (24 V DC), VARIOSUB push/pull connection method, rugged metal housing, degree of protection IP67

Why buy this product

- Rugged metal housing
- Comprehensive diagnostic functions
- Push/pull connector for supply voltage
- M12 connector for I/O devices
- Push/pull connector for PROFINET, either with fiber optic or twisted pair



Key Commercial Data

Packing unit	1 STK
GTIN	 4 046356 435987

Technical data

Note

Utilization restriction	EMC: class A product, see manufacturer's declaration in the download area
-------------------------	---

Dimensions

Width	182.5 mm
Height	71.5 mm
Depth	79.8 mm
Note on dimensions	Without connector, with mounting plate

Ambient conditions

Ambient temperature (operation)	-20 °C ... 55 °C
Ambient temperature (storage/transport)	-25 °C ... 85 °C
Permissible humidity (operation)	100 %
Permissible humidity (storage/transport)	95 % (non-condensing)
Air pressure (operation)	860 hPa ... 1080 hPa (up to 1500 m above mean sea level)

Distributed I/O device - RL PN 24-2 DI 16 2TX - 2773665

Technical data

Ambient conditions

Air pressure (storage/transport)	660 hPa ... 1080 hPa (up to 3500 m above mean sea level)
Degree of protection	IP65/IP67

General

Net weight	1180 g
Note on weight specifications	Without plug or mounting plate
Mounting type	Wall mounting
Note	Seal unused slots/connections to ensure the degree of protection.

Interfaces

Fieldbus system	PROFINET
Designation	PROFINET
Connection method	VARIOSUB push-pull connectors
Designation connection point	Copper cable
Transmission speed	10/100 MBit/s (auto negotiation)
Transmission physics	Twisted pair connection
Number of positions	4

Power supply for module electronics

Connection method	VARIOSUB push-pull connectors
Designation	US1
Supply voltage	24 V DC
Supply voltage range	18.5 V DC ... 30 V DC (including ripple)
Ripple	Max 3.6 V _{SS} within the permissible voltage range

Digital inputs

Input name	Digital inputs
Connection method	M12 connector
	2, 3, 4-wire
Number of inputs	16
Protective circuit	Electronic short-circuit/overload protection for each group Protection against polarity reversal
Input characteristic curve	IEC 61131-2 type 1

Standards and Regulations

Test section	Between bus logic and outputs 500 V AC 50 Hz 1 min.
Protection class	III, IEC 61140, EN 61140, VDE 0140-1

Classifications

eCl@ss

eCl@ss 4.0	27250302
eCl@ss 4.1	27250302
eCl@ss 5.0	27250302

Distributed I/O device - RL PN 24-2 DI 16 2TX - 2773665

Classifications

eCl@ss

eCl@ss 5.1	27242604
eCl@ss 6.0	27242604
eCl@ss 7.0	27242604
eCl@ss 8.0	27242604
eCl@ss 9.0	27242604

ETIM

ETIM 2.0	EC001430
ETIM 3.0	EC001599
ETIM 4.0	EC001599
ETIM 5.0	EC001599

UNSPSC

UNSPSC 6.01	43172015
UNSPSC 7.0901	43201404
UNSPSC 11	43172015
UNSPSC 12.01	43201404
UNSPSC 13.2	43201404

Approvals

Approvals

Approvals

UL Listed / cUL Listed / cULus Listed

Ex Approvals

Approvals submitted

Approval details

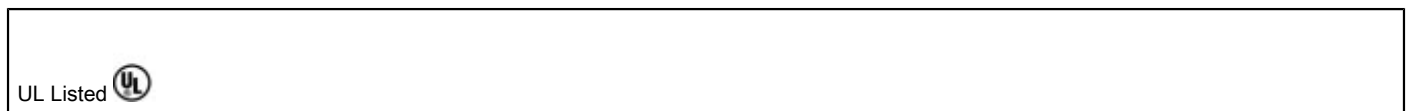

Distributed I/O device - RL PN 24-2 DI 16 2TX - 2773665

Approvals



Drawings

Connection diagram

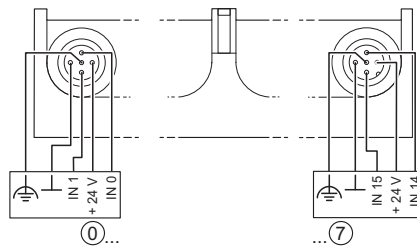

Functional drawing

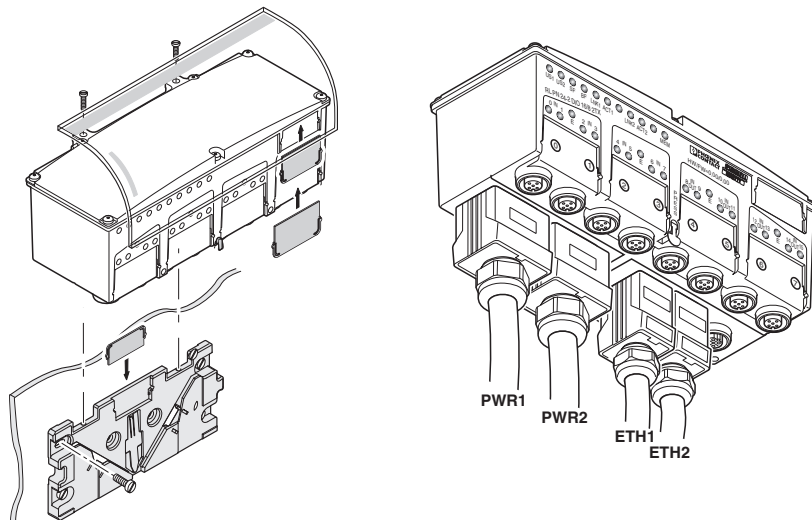

Phoenix Contact 2016 © - all rights reserved
<http://www.phoenixcontact.com>

PHOENIX CONTACT GmbH & Co. KG
Flachsmarktstr. 8
32825 Blomberg
Germany
Tel. +49 5235 300
Fax +49 5235 3 41200
<http://www.phoenixcontact.com>



Below is a list of articles with direct links to our shop Electric Automation Network where you can see:

- Quote per purchase volume in real time.
- Online documentation and datasheets of all products.
- Estimated delivery time enquiry in real time.
- Logistics systems for the shipment of materials almost anywhere in the world.
- Purchasing management, order record and tracking of shipments.

To access the product, [click on the green button.](#)

Product	Code	Reference	Product link
Digital input device for PROFINET, 100Base-TX, fast startup, supported protocols: SNMPv2, TFTP, LLDP andPDev for topology detection, 16 inputs (24 V DC), VARIOSUB push/pull connection method, rugged metal housing, degree of protection IP67	2773665	RL PN 24-2 DI 16 2TX	Buy on EAN