



Automatización Eléctrica
Especialistas en Automatización

At the end of this document you will find links to products related to this catalog. You can go directly to our shop by clicking [HERE](#). [HERE](#)

Sensor/actuator box - SACB-8/16-L-C SCO OTB - 1437232

Please be informed that the data shown in this PDF Document is generated from our Online Catalog. Please find the complete data in the user's documentation. Our General Terms of Use for Downloads are valid (<http://phoenixcontact.com/download>)

Sensor/actuator box, Application: Standard, Connection method: M12-SPEEDCON-socket Metal, Number of slots: 8, Number of positions: 5, Coding: A - standard, Slot assignment: Double, Status indication: Yes, pnp; Master cable connection: Rear plug-in spring connection 270°, Shielding: No



The figure shows the top and bottom side of the article

Why buy this product

- Safety in the field, thanks to molded housing and high degree of protection
- Flexible, distributed bundling of signals in one master cable
- Convenient: increased machine availability thanks to quick and easy diagnostics
- Save space: distributor box with double occupancy for two sensors in one slot
- Save time, thanks to installation with SPEEDCON fast locking system
- Easy PLC system cabling, thanks to master connection on the back



Key Commercial Data

Packing unit	1 STK
GTIN	4 046356 455626

Technical data

General

Rated voltage	24 V DC
Max. operating voltage U_{max}	30 V DC
Current carrying capacity per I/O signal	2 A
Current carrying capacity per slot	4 A
Total rated current	8 A
Number of positions	5
Number of slots	8
Sensor/actuator connection system	M12-SPEEDCON-socket

Ambient conditions

Degree of protection	IP54 (with sealed mounting holes)
----------------------	-----------------------------------

Sensor/actuator box - SACB-8/16-L-C SCO OTB - 1437232

Technical data

Ambient conditions

Ambient temperature (operation)	-30 °C ... 80 °C
Ambient temperature (storage/transport)	-30 °C ... 90 °C

Local diagnostics function

Local diagnostics	Supply voltage Green LED
	Status display I/O Yellow LED

Master cable data/connection data

Connection method	Rear plug-in spring connection
Conductor cross section min. (signal)	0.14 mm ²
Conductor cross section max. (signal)	1.5 mm ²
Conductor cross section AWG min. (signal)	26
Conductor cross section AWG max. (signal)	16
Stripping length (signal)	9 mm
Conductor cross section min. (energy)	0.14 mm ²
Conductor cross section max. (energy)	1.5 mm ²
Conductor cross section AWG min. (energy)	26
Conductor cross section AWG max. (energy)	16
Tightening torque slot sensor/actuator cable	0.4 Nm
Tightening torque of mounting screw for fixing the housing	0.5 Nm

Insulation material

Housing material	PBT
Material of the moulding mass	PUR
Contact material	Cu alloy
Contact surface material	Gold-plated
Contact carrier material	PA
Material of contact, master cable side	CU alloy
Material of contact surface, master cable side	tin-plated
Material of the contact carrier on the master cable side	PA
Material of threaded sleeve	Zinc die-cast
Material of threaded sleeve surface	Nickel-plated
O-ring material	NBR
Sealing material	CR (flat gasket on the back)

Pin assignment

Slot/position = Wire color or connection	1 / 4 (A) = 1 / 4
	1 / 2 (B) = 1 / 2
	2 / 4 (A) = 2 / 4
	2 / 2 (B) = 2 / 2
	3 / 4 (A) = 3 / 4
	3 / 2 (B) = 3 / 2
	4 / 4 (A) = 4 / 4

Sensor/actuator box - SACB-8/16-L-C SCO OTB - 1437232

Technical data

Pin assignment

	4 / 2 (B) = 4 / 2
	5 / 4 (A) = 5 / 4
	5 / 2 (B) = 5 / 2
	6 / 4 (A) = 6 / 4
	6 / 2 (B) = 6 / 2
	7 / 4 (A) = 7 / 4
	7 / 2 (B) = 7 / 2
	8 / 4 (A) = 8 / 4
	8 / 2 (B) = 8 / 2
	1-8 / 1 (+ 24 V) = U _N
	1-8 / 3 (0 V) = 0 V
	1-8 / 5 (PE) = PE

Standards and Regulations

Standard designation	M12 connector
Standards/regulations	IEC 61076-2-101

Classifications

eCl@ss

eCl@ss 4.0	27250313
eCl@ss 4.1	27250313
eCl@ss 5.0	27143423
eCl@ss 5.1	27143423
eCl@ss 6.0	27143423
eCl@ss 7.0	27449001
eCl@ss 8.0	27279219

ETIM

ETIM 3.0	EC001856
ETIM 4.0	EC002585
ETIM 5.0	EC002585

UNSPSC

UNSPSC 6.01	31261501
UNSPSC 7.0901	31261501
UNSPSC 11	31261501
UNSPSC 12.01	31261501
UNSPSC 13.2	31261501

Sensor/actuator box - SACB-8/16-L-C SCO OTB - 1437232

Approvals

Approvals

Approvals

EAC

Ex Approvals

Approvals submitted

Approval details

EAC

Drawings

Schematic diagram

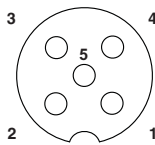

Pin assignment M12 socket, 5-pos.

Circuit diagram

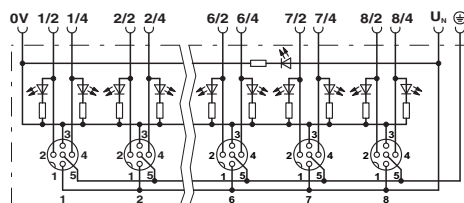

Dimensional drawing

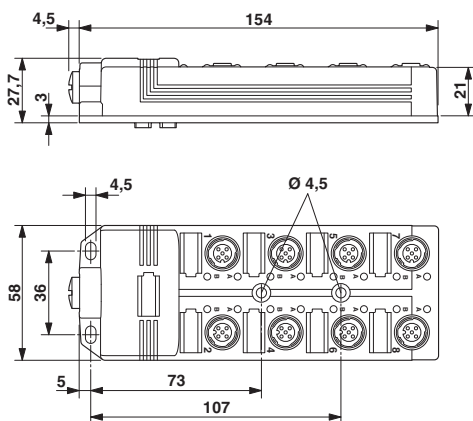

Dimensional drawing

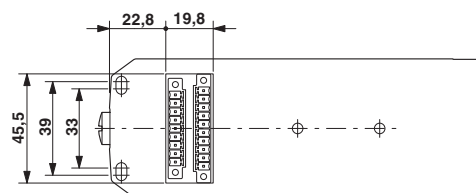

Phoenix Contact 2016 © - all rights reserved
<http://www.phoenixcontact.com>

PHOENIX CONTACT GmbH & Co. KG
Flachsmarktstr. 8
32825 Blomberg
Germany
Tel. +49 5235 300
Fax +49 5235 3 41200
<http://www.phoenixcontact.com>

Below is a list of articles with direct links to our shop Electric Automation Network where you can see:

- Quote per purchase volume in real time.
- Online documentation and datasheets of all products.
- Estimated delivery time enquiry in real time.
- Logistics systems for the shipment of materials almost anywhere in the world.
- Purchasing management, order record and tracking of shipments.

To access the product, [click on the green button.](#)

Product	Code	Reference	Product link
Sensor/actuator box, Application: Standard, Connection method: M12-SPEEDCON-socket Metal, Number of slots: 8, Number of positions: 5, Coding: A - standard, Slot assignment: Double, Status indication: Yes, pnp; Master cable connection: Rear plug-in spring connection 270°, Shielding: No	1437232	SACB-8/16-L-C SCO OTB	Buy on EAN