



Automatización Eléctrica
Especialistas en Automatización

At the end of this document you will find links to products related to this catalog. You can go directly to our shop by clicking [HERE](#). [HERE](#)

USB memory stick - VS-04-MS-IP67 - 1402489

Please be informed that the data shown in this PDF Document is generated from our Online Catalog. Please find the complete data in the user's documentation. Our General Terms of Use for Downloads are valid (<http://phoenixcontact.com/download>)

USB memory stick, IP67, 8 GB, USB 2.0, designed to connect through the panel mounting frame VS-A-F-IP67 on the VARIOSUB-USB socket inserts



Product Description

With USB extension cable (connector A to socket A) 1.5 m

Key Commercial Data

Packing unit	1 STK
GTIN	 4 046356 621427

Technical data

General data

Number of positions	4
---------------------	---

Classifications

eCl@ss

eCl@ss 4.0	272607xx
eCl@ss 4.1	27260701
eCl@ss 5.0	27260701
eCl@ss 5.1	27260701
eCl@ss 6.0	19150701
eCl@ss 7.0	19150701
eCl@ss 8.0	19159090

ETIM

ETIM 4.0	EC001068
ETIM 5.0	EC001068

UNSPSC

UNSPSC 6.01	31261501
UNSPSC 7.0901	31261501

USB memory stick - VS-04-MS-IP67 - 1402489

Classifications

UNSPSC

UNSPSC 11	31261501
UNSPSC 12.01	31261501
UNSPSC 13.2	31261501

Drawings

Dimensional drawing

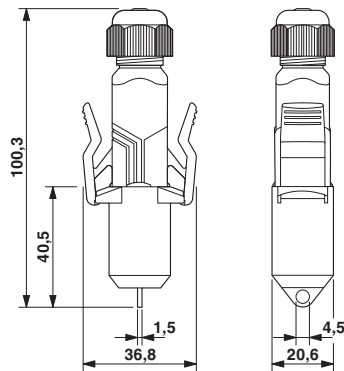

USB memory stick, IP67

Phoenix Contact 2016 © - all rights reserved
<http://www.phoenixcontact.com>

PHOENIX CONTACT GmbH & Co. KG
Flachsmarktstr. 8
32825 Blomberg
Germany
Tel. +49 5235 300
Fax +49 5235 3 41200
<http://www.phoenixcontact.com>



Below is a list of articles with direct links to our shop Electric Automation Network where you can see:

- Quote per purchase volume in real time.
- Online documentation and datasheets of all products.
- Estimated delivery time enquiry in real time.
- Logistics systems for the shipment of materials almost anywhere in the world.
- Purchasing management, order record and tracking of shipments.

To access the product, [click on the green button.](#)

Product	Code	Reference	Product link
USB memory stick, IP67, 8 GB, USB 2.0, designed to connect through the panel mounting frame VS-A-F-IP67 on the VARIOSUB-USB socket inserts	1402489	VS-04-MS-IP67	Buy on EAN