



**Automatización Eléctrica**  
Especialistas en Automatización

At the end of this document you will find links to products related to this catalog. You can go directly to our shop by clicking [HERE](#). [HERE](#)

## End clamp - E/AL-NS 35 - 1201662

Please be informed that the data shown in this PDF Document is generated from our Online Catalog. Please find the complete data in the user's documentation. Our General Terms of Use for Downloads are valid (<http://phoenixcontact.com/download>)



End clamp, for end support of UKH 50 to UKH 240, is pushed onto DIN rail NS 35 and fixed with 2 screws, width: 10 mm, color: aluminum

### Why buy this product

- Large-surface labeling
- The E/AL-NS 35 provides optimum support for large terminal blocks and devices

### Key Commercial Data

Packing unit	10 STK
GTIN	 4 017918 017439

### Technical data

#### Dimensions

Height	44 mm
Length	59 mm
Width	10 mm

#### General

Material	Aluminum
Color	silver
Tightening torque, min	0.4 Nm
Tightening torque max	0.5 Nm

### Classifications

#### eCl@ss

eCl@ss 4.0	27141199
eCl@ss 4.1	27141199
eCl@ss 5.0	27141135
eCl@ss 5.1	27141145
eCl@ss 6.0	27141135
eCl@ss 7.0	27141135

## End clamp - E/AL-NS 35 - 1201662

### Classifications

#### eCl@ss

eCl@ss 8.0	27141135
------------	----------

#### ETIM

ETIM 2.0	EC000761
ETIM 3.0	EC001041
ETIM 4.0	EC001041
ETIM 5.0	EC001041

#### UNSPSC

UNSPSC 6.01	30212109
UNSPSC 7.0901	39121708
UNSPSC 11	39121708
UNSPSC 12.01	39121708
UNSPSC 13.2	39121708

### Drawings

## End clamp - E/AL-NS 35 - 1201662

Dimensional drawing

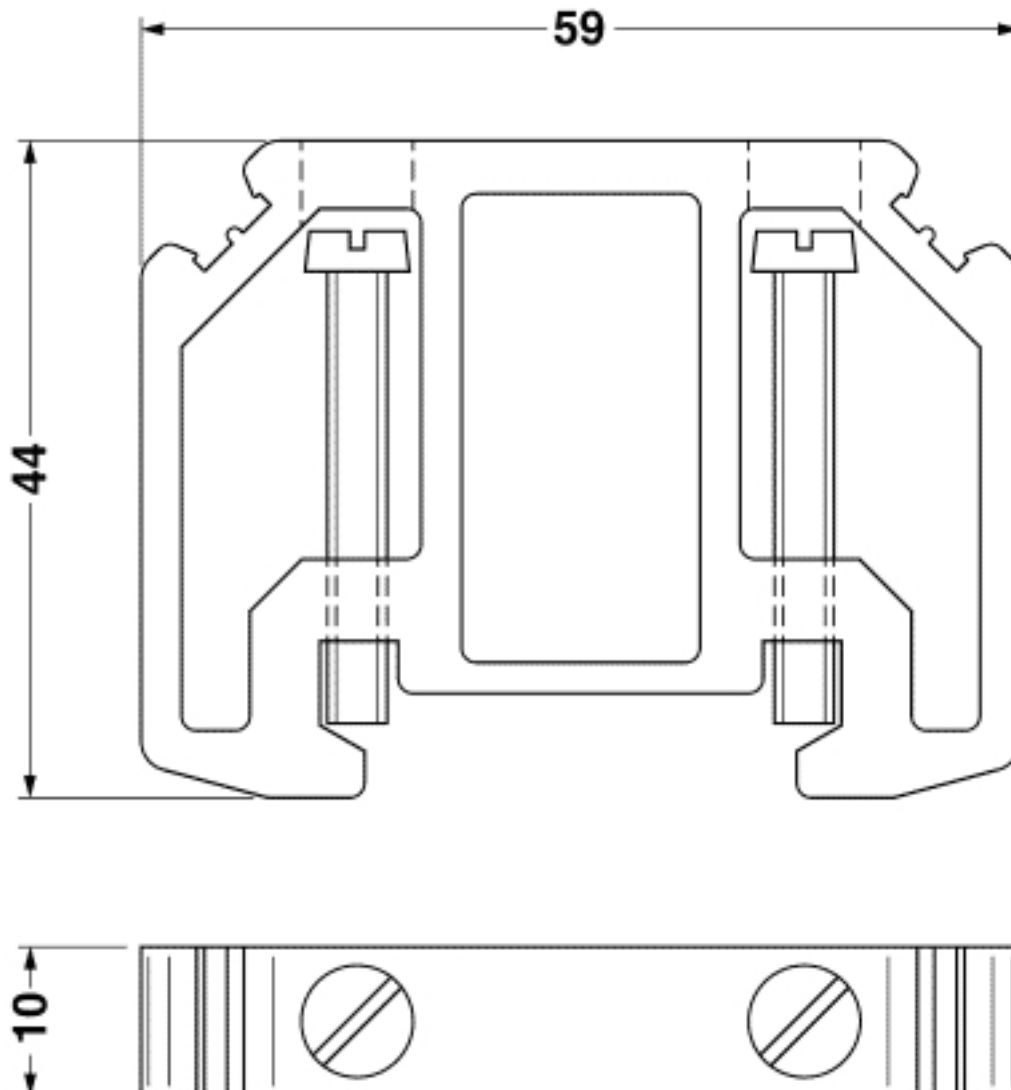

Phoenix Contact 2016 © - all rights reserved  
<http://www.phoenixcontact.com>

PHOENIX CONTACT GmbH & Co. KG  
Flachsmarktstr. 8  
32825 Blomberg  
Germany  
Tel. +49 5235 300  
Fax +49 5235 3 41200  
<http://www.phoenixcontact.com>



Below is a list of articles with direct links to our shop Electric Automation Network where you can see:

- Quote per purchase volume in real time.
- Online documentation and datasheets of all products.
- Estimated delivery time enquiry in real time.
- Logistics systems for the shipment of materials almost anywhere in the world.
- Purchasing management, order record and tracking of shipments.

To access the product, [click on the green button.](#)

Product	Code	Reference	Product link
End clamp, for end support of UKH 50 to UKH 240, is pushed onto DIN rail NS 35 and fixed with 2 screws, width: 10 mm, color: aluminum	1201662	E/AL-NS 35	<a href="#">Buy on EAN</a>