



**Automatización Eléctrica**  
Especialistas en Automatización

At the end of this document you will find links to products related to this catalog. You can go directly to our shop by clicking [HERE](#). [HERE](#)

## Rail adapters - USA 10 - 1201578

Please be informed that the data shown in this PDF Document is generated from our Online Catalog. Please find the complete data in the user's documentation. Our General Terms of Use for Downloads are valid (<http://phoenixcontact.com/download>)



Rail adapters, for M3 screws, Length: 42.6 mm, Width: 10 mm, Height: 19 mm, Color: gray

The illustration shows versions USA 10 and USA 10/4,6

### Why buy this product

- The universal adapters are used to secure and hold electrical or electronic switching devices
- They allow fully insulated mounting of components or DIN rails

### Key Commercial Data

Packing unit	10 STK
Minimum order quantity	10 STK
GTIN	 4 017918 017392

### Technical data

#### Dimensions

Height	19 mm
Length	42.6 mm
Width	10 mm

#### General

Material	PA
Coating	uncoated
Color	gray

#### Standards and Regulations

Flammability rating according to UL 94	V2
--	----

### Classifications

#### eCl@ss

eCl@ss 4.0	27141199
eCl@ss 4.1	27141199

## Rail adapters - USA 10 - 1201578

### Classifications

#### eCl@ss

eCl@ss 5.0	27370419
eCl@ss 5.1	27370419
eCl@ss 6.0	27370419
eCl@ss 7.0	27370419
eCl@ss 8.0	27149214

#### ETIM

ETIM 2.0	EC000761
ETIM 3.0	EC000761
ETIM 4.0	EC001024
ETIM 5.0	EC001024

#### UNSPSC

UNSPSC 6.01	30211802
UNSPSC 7.0901	39121402
UNSPSC 11	39121402
UNSPSC 12.01	39121402
UNSPSC 13.2	39121402

### Drawings

## Rail adapters - USA 10 - 1201578

Dimensional drawing

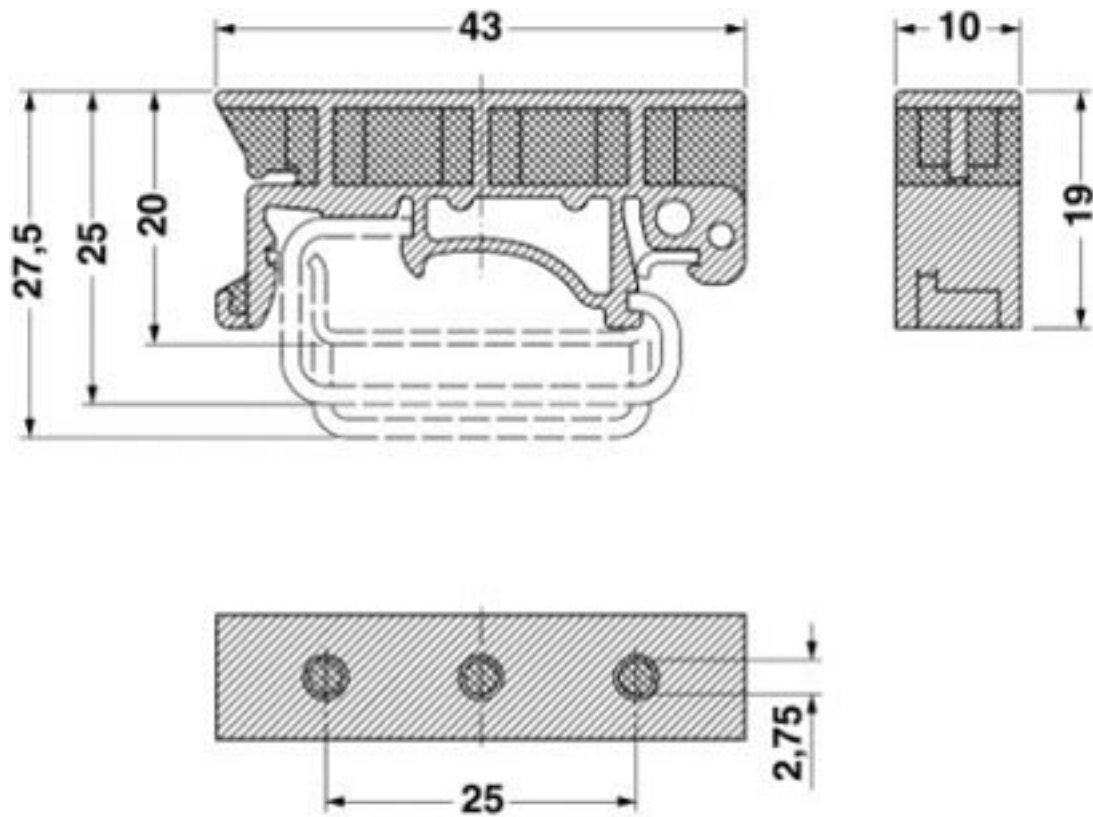

Phoenix Contact 2016 © - all rights reserved  
<http://www.phoenixcontact.com>

PHOENIX CONTACT GmbH & Co. KG  
Flachsmarktstr. 8  
32825 Blomberg  
Germany  
Tel. +49 5235 300  
Fax +49 5235 3 41200  
<http://www.phoenixcontact.com>



Below is a list of articles with direct links to our shop Electric Automation Network where you can see:

- Quote per purchase volume in real time.
- Online documentation and datasheets of all products.
- Estimated delivery time enquiry in real time.
- Logistics systems for the shipment of materials almost anywhere in the world.
- Purchasing management, order record and tracking of shipments.

To access the product, [click on the green button.](#)

Product	Code	Reference	Product link
Rail adapters, for M3 screws, Length: 42.6 mm, Width: 10 mm, Height: 19 mm, Color: gray	1201578	USA 10	<a href="#">Buy on EAN</a>