

The OMRON logo is displayed in a bold, blue, sans-serif font. The letters are thick and closely spaced, with a consistent height and width throughout the word.

Automatización Eléctrica
Especialistas en Automatización

At the end of this document you will find links to products related to this catalog. You can go directly to our shop by clicking [HERE](#). [HERE](#)



Machine Automation Controller CJ-series 4-Channel Counter Unit

Operation Manual for NJ-series CPU Unit

CJ1W-CTL41-E

4-Channel Counter Unit



W512-E2-01

Introduction

Thank you for purchasing a CJ-series CJ1W-CTL41-E 4-Channel Counter Unit.

This manual contains information that is necessary to use the CJ-series CJ1W-CTL41-E 4-Channel Counter Unit for an NJ-series CPU Unit. Please read this manual and make sure you understand the functionality and performance of the NJ-series CPU Unit before you attempt to use it in a control system.

Keep this manual in a safe place where it will be available for reference during operation.

Intended Audience

This manual is intended for the following personnel, who must also have knowledge of electrical systems (an electrical engineer or the equivalent).

- Personnel in charge of introducing FA systems.
- Personnel in charge of designing FA systems.
- Personnel in charge of installing and maintaining FA systems.
- Personnel in charge of managing FA systems and facilities.

For programming, this manual is intended for personnel who understand the programming language specifications in international standard IEC 61131-3 or Japanese standard JIS B3503.

Applicable Products

This manual covers the following products.

CJ-series CJ1W-CTL41-E 4-Channel Counter Unit

Relevant Manuals

There are three manuals that provide basic information on the NJ-series CPU Units: the *NJ-series CPU Unit Hardware User's Manual*, the *NJ-series CPU Unit Software User's Manual* and the *NJ-series Instructions Reference Manual*.

Most operations are performed from the Sysmac Studio Automation Software. Refer to the *Sysmac Studio Version 1 Operation Manual* (Cat. No. W504) for information on the Sysmac Studio.

Other manuals are necessary for specific system configurations and applications.

Read all of the manuals that are relevant to your system configuration and application to make the most of the NJ-series CPU Unit.

	NJ-series User's Manuals								
	Basic information			NJ-series CPU Unit Motion Control User's Manual	NJ-series CPU Unit Built-in EtherCAT Port User's Manual	NJ-series Motion Control Instructions Reference Manual	NJ-series CPU Unit Built-in EtherNet/IP Port User's Manual	NJ-series Troubleshooting Manual	CJ-series Special Unit Operation Manuals for NJ-series CPU Unit
	NJ-series CPU Unit Hardware User's Manual	NJ-series CPU Unit Software User's Manual	NJ-series Instructions Reference Manual						
Introduction to NJ-series Controllers	●								
Setting devices and hardware									
Using motion control				●					
Using EtherCAT	●				●				
Using EtherNet/IP						●			
Using CJ-series Units								●	
Software settings									
Using motion control		●		●					
Using EtherCAT					●				
Using EtherNet/IP						●			
Programming									
Using motion control		●	●	●	●				
Using EtherCAT					●				
Using CJ-series Units								●	
Programming error processing								●	
Testing operation and debugging									
Using motion control		●		●					
Using EtherCAT					●				
Using EtherNet/IP						●			
Troubleshooting and managing errors in an NJ-series Controller	△	△		△		△		△	
	Use the relevant manuals for references according to any error that occurs.								
Maintenance									
Using EtherCAT	●				●				
Using EtherNet/IP						●			
Using CJ-series Units								●	

Manual Configuration

NJ-series CPU Unit Hardware User's Manual (Cat. No. W500)

Section	Description
Section 1 Introduction	This section provides an introduction to the NJ-series Controllers and their features, and gives the NJ-series Controller specifications.
Section 2 System Configuration	This section describes the system configuration used for NJ-series Controllers.
Section 3 Configuration Units	This section describes the parts and functions of the configuration devices in the NJ-series Controller configuration, including the CPU Unit and Configuration Units.
Section 4 Installation and Wiring	This section describes where and how to install the CPU Unit and Configuration Units and how to wire them.
Section 5 Troubleshooting	This section describes the event codes, error confirmation methods, and corrections for errors that can occur.
Section 6 Inspection and Maintenance	This section describes the contents of periodic inspections, the service life of the Battery and Power Supply Units, and replacement methods for the Battery and Power Supply Units.
Appendices	The appendices provide the specifications of the Basic I/O Units, Unit dimensions, load short-circuit protection detection, line disconnection detection, and measures for EMC Directives.

NJ-series CPU Unit Software User's Manual (Cat. No. W501)

Section	Description
Section 1 Introduction	This section provides an introduction to the NJ-series Controllers and their features, and gives the NJ-series Controller specifications.
Section 2 CPU Unit Operation	This section describes the variables and control systems of the CPU Unit and CPU Unit status.
Section 3 I/O Ports, Slave Configuration, and Unit Configuration	This section describes how to use I/O ports, how to create the slave configuration and unit configuration and how to assign functions.
Section 4 Controller Setup	This section describes the initial settings of the function modules.
Section 5 Designing Tasks	This section describes the task system and types of tasks.
Section 6 Programming	This section describes programming, including the programming languages and the variables and instructions that are used in programming.
Section 7 Simulation, Transferring Projects to the Physical CPU Unit, and Operation	This section describes simulation of Controller operation and how to use the results of simulation.
Section 8 CPU Unit Status	This section describes CPU Unit status.
Section 9 CPU Unit Functions	This section describes the functionality provided by the CPU Unit.
Section 10 Communications Setup	This section describes how to go online with the CPU Unit and how to connect to other devices.
Section 11 Example of Actual Application Procedures	This section describes the procedures that are used to actually operate an NJ-series Controller.
Section 12 Troubleshooting	This section describes the event codes, error confirmation methods, and corrections for errors that can occur.
Appendices	The appendices provide the CPU Unit specifications, task execution times, system-defined variable lists, data attribute lists, CJ-series Unit memory information, CJ-series Unit memory allocation methods, and data type conversion information.

Sysmac Studio Version 1 Operation Manual (Cat. No. W504)

Section	Description
Section 1 Introduction	This section provides an overview and lists the specifications of the Sysmac Studio and describes its features and components.
Section 2 Installation and Uninstallation	This section describes how to install and uninstall the Sysmac Studio.
Section 3 System Design	This section describes the basic concepts for designing an NJ-series System with the Sysmac Studio and the basic operating procedures.
Section 4 Programming	This section describes how to create programs with the Sysmac Studio.
Section 5 Online Connections to a Controller	This section describes how to go online with a Controller.
Section 6 Debugging	This section describes how to debug the programs online on the Controller or debug it offline with the Simulator.
Section 7 Other Functions	This section describes Sysmac Studio functions other than system design functions.
Section 8 Reusing Programming	This section describes how to reuse the programs that you create with the Sysmac Studio.
Section 9 Support Software Provided with the Sysmac Studio	This section describes the Support Software that is provided with the Sysmac Studio.
Section 10 Troubleshooting	This section describes the error messages that are displayed when you check a program on the Sysmac Studio and how to correct those errors.
Appendices	The appendices describe the following: Driver Installation for Direct USB Cable Connection Specifying One of Multiple Ethernet Interface Cards Online Help Simulation Instructions

CJ-series 4-Channel Counter Unit Operation Manual for NJ-series CPU Unit (Cat. No W512) (This Manual)

Section	Description
Section 1 Introduction	This section describes the functionality and the specifications of the 4-Channel Counter Unit, and the operating procedure.
Section 2 Components, Installation and Wiring	This section describes the details of the components and where and how to install and wire the 4-Channel Counter Unit.
Section 3 Operation and Configuration	This section describes the functionality of the 4-Channel Counter Unit and how to configure the Unit.
Section 4 Exchanging Data with CPU	This section describes the data exchange between the CPU Unit and 4-Channel Counter Unit and the definitions of the device variables for CJ-series Unit.
Section 5 Error Processing, Maintenance and Inspection	This section describes the troubleshooting procedure, event logs and maintenance procedure for the 4-Channel Counter Unit.
Appendices	---

CJ-series 4-Channel Counter Unit Operation Manual (Cat. No. W02E)

Section	Description
Section 1 Introduction	This section gives specifications of the CJ1W-CTL41-E and a brief description of the functions and features of the Unit and the areas of application.
Section 2 Components, Installation and Wiring	This section provides details of the components, switch settings and other information required to install and operate CJ1W-CTL41-E Counter Units.
Section 3 Operation and Configuration	This section describes how to configure the CJ1W-CTL41-E Counter Unit and how to operate the Unit according to the specific requirements of your application.
Section 4 Exchanging Data with CPU	This section provides information on exchanging data between CJ1W-CTL41-E Counter Units and CJ-series CPU Units.
Section 5 Error Processing, Maintenance and Inspection	This section provides details of the CJ1W-CTL41-E Counter Unit's error indicators and error codes and guidelines for maintenance and inspection of the Unit.
Appendices	---

Manual Structure

Page Structure

The following page structure is used in this manual.

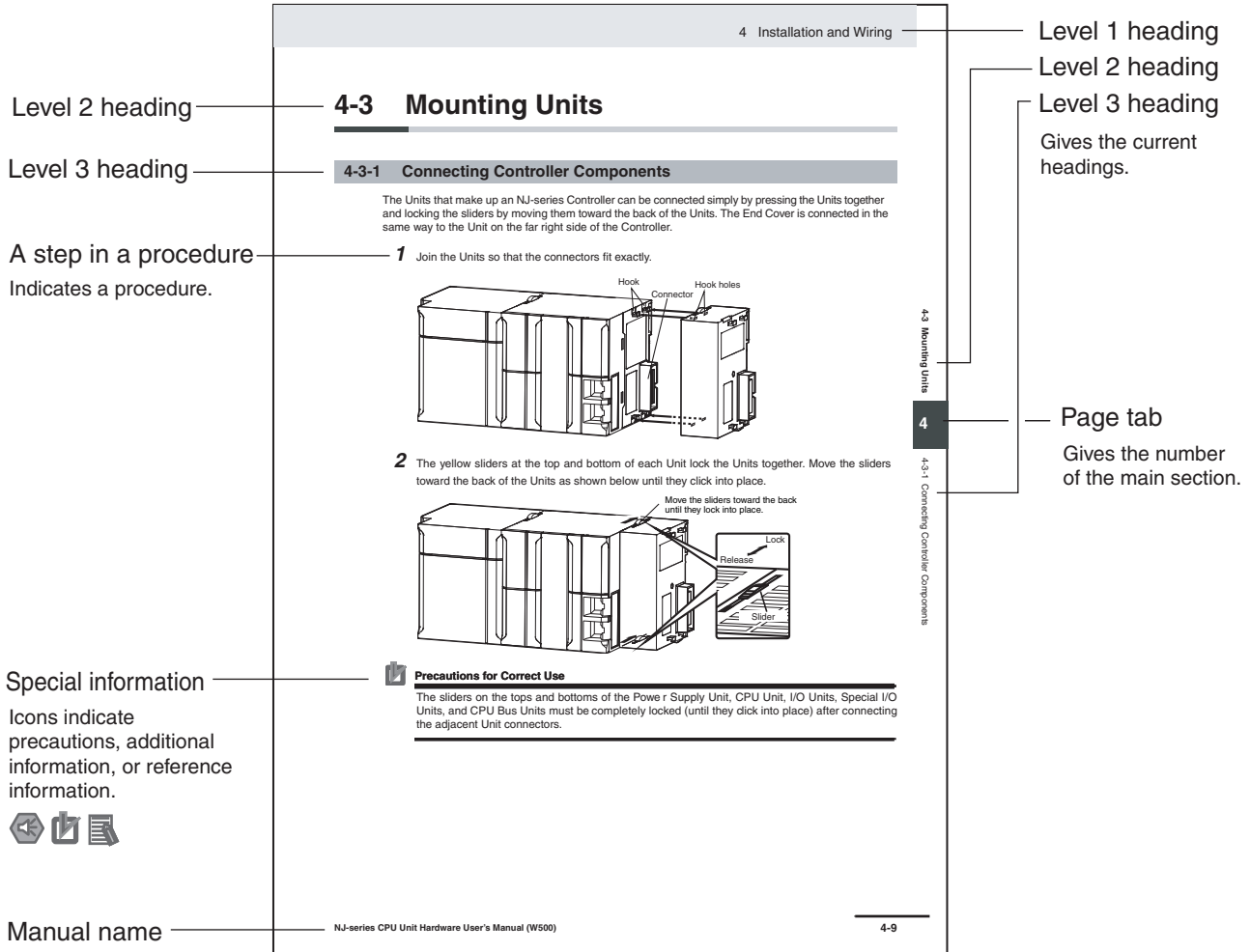

This illustration is provided only as a sample. It may not literally appear in this manual.

Special Information

Special information in this manual is classified as follows:



Precautions for Safe Use

Precautions on what to do and what not to do to ensure safe usage of the product.



Precautions for Correct Use

Precautions on what to do and what not to do to ensure proper operation and performance.



Additional Information

Additional information to read as required.

This information is provided to increase understanding or make operation easier.

Note References are provided to more detailed or related information.

Precaution on Terminology

In this manual, “download” refers to transferring data from the Sysmac Studio to the physical Controller and “upload” refers to transferring data from the physical Controller to the Sysmac Studio.

The terms “Counter Unit”, “4-Channel Counter Unit” and “CJ1W-CTL41-E” maybe be interchanged in this manual when referring to the CJ1W-CTL41-E 4-Channel Counter Unit.

Sections in this Manual

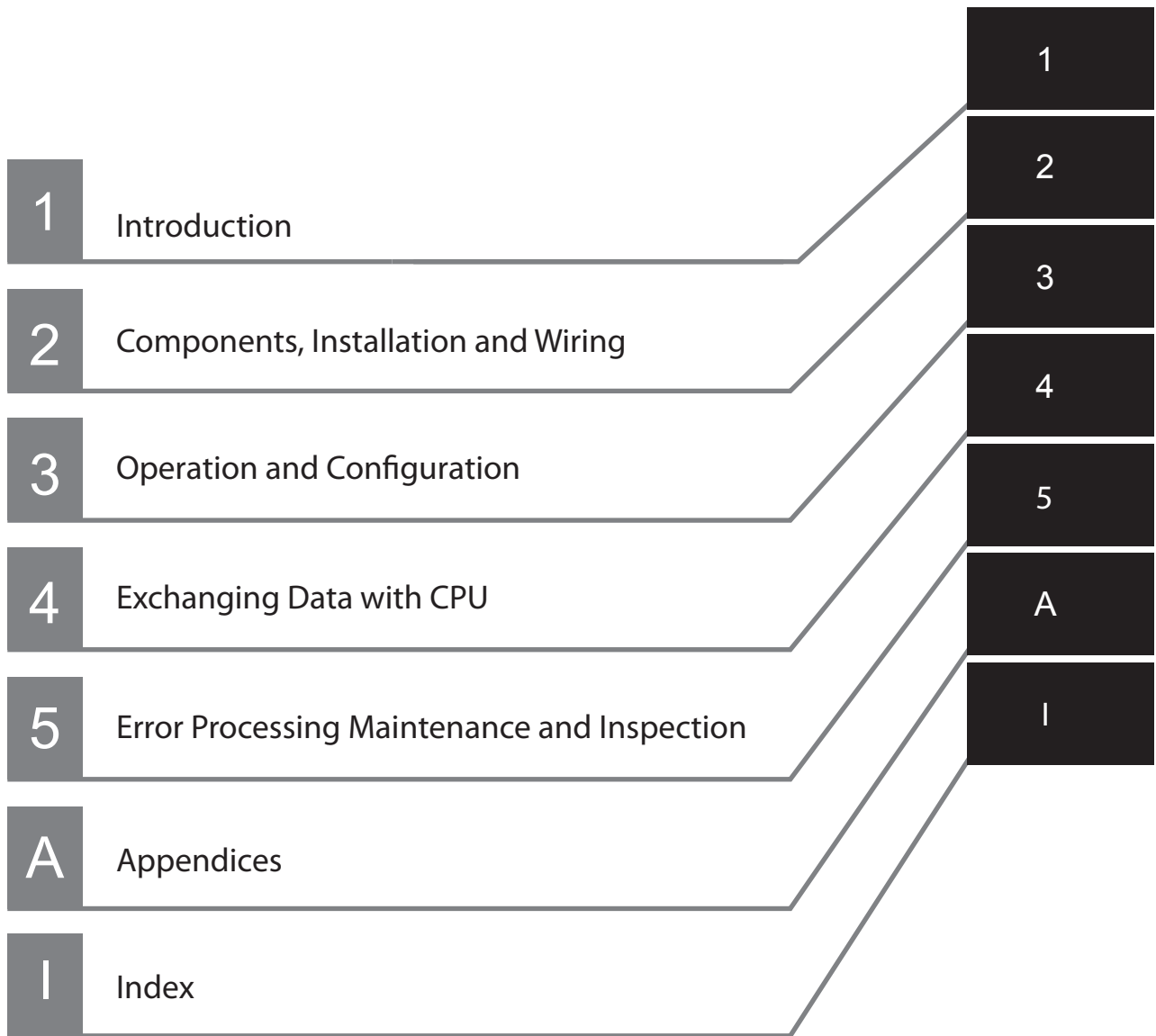

CONTENTS

Introduction	1
Relevant Manuals	2
Manual Configuration	3
Manual Structure	6
Sections in this Manual	8
CONTENTS	10
Read and Understand this Manual	14
Safety Precautions	17
Precautions for Safe Use	22
Precautions for Correct Use	28
Unit Versions	33
Related Manuals	35
Revision History	36

Section 1 Introduction

1-1 Features and Functions	1-2
1-2 Basic Configuration	1-4
1-3 Specifications and Characteristics	1-6
1-3-1 General Specifications	1-6
1-3-2 Functional Specifications	1-6
1-3-3 Input Specifications	1-7
1-4 Quick Start Up Reference Guide	1-10
1-4-1 Configuring the Counter Unit	1-10
1-5 Operating Procedure Guidelines	1-12
1-6 Application Areas	1-14

Section 2 Components, Installation and Wiring

2-1 Components and Switch Settings	2-2
2-1-1 Components	2-2
2-1-2 Indicators	2-2
2-1-3 Machine Number Switch	2-3
2-2 Installation	2-5
2-2-1 System Configuration Precautions	2-5
2-2-2 Installing Units	2-5
2-3 Wiring	2-7
2-3-1 Connector Pin Layout	2-7

2-3-2	Connector Wiring Methods	2-8
2-3-3	Important Wiring Considerations	2-9
2-3-4	Internal Circuitry	2-10
2-3-5	Counter Input Configuration	2-10

Section 3 Operation and Configuration

3-1	Overview	3-2
3-1-1	Summary	3-2
3-1-2	List of Functions/Allocation Areas by Purpose	3-2
3-2	Counter Types	3-4
3-2-1	Circular Counter	3-4
3-2-2	Linear Counter	3-5
3-3	Input Signal Types	3-8
3-3-1	Phase Differential	3-8
3-3-2	Up & Down Pulse	3-9
3-3-3	Pulse & Direction	3-9
3-4	Controlling a Counter	3-11
3-5	Output Control	3-13
3-5-1	Range Mode	3-14
3-5-2	Comparison Mode	3-20
3-6	Reset Signals	3-27
3-7	Extra Functions	3-29
3-7-1	Hysteresis	3-29
3-7-2	Initial Counter Value	3-30

Section 4 Exchanging Data with CPU

4-1	Overview	4-2
4-1-1	Data Flow	4-2
4-1-2	Unit Restart	4-4
4-1-3	Access from User Program	4-5
4-2	Memory Allocation	4-7
4-2-1	Memory Mapping	4-7
4-2-2	Allocating Ranges and Comparison Data	4-8
4-2-3	Details of Device Variables for CJ-series Unit (for input/output)	4-12
4-2-4	Details of Device Variables for CJ-series Unit (for setting)	4-16
4-2-5	Memory Allocation for Ranges	4-19
4-2-6	Memory Allocation for Comparison Data	4-20

Section 5 Error Processing, Maintenance and Inspection

5-1	Error Indicators	5-2
5-1-1	Errors during initial processing	5-2
5-1-2	Errors during normal operation	5-2
5-2	Error Codes	5-3
5-2-1	DM-configuration errors	5-4
5-2-2	Overflow/Underflow errors	5-5
5-2-3	System Errors	5-5
5-2-4	Preset Error	5-5
5-3	Event Log	5-7
5-3-1	Overview of the Event Logs	5-7
5-3-2	Error Table	5-7
5-3-3	Error Descriptions	5-8

5-4 Maintenance and Inspection 5-10
5-4-1 Cleaning 5-10
5-4-2 Routine Inspections 5-10

Appendices

A-1 Differences of NJ Series from CJ Series A-2
A-1-1 Functional Difference A-2
A-1-2 Differences in Access Methods from a User Program A-3
A-2 Using Terminal Block Units with Screw-terminals A-14
A-3 Application Restrictions A-16

Index

Read and Understand this Manual

Please read and understand this manual before using the product. Please consult your OMRON representative if you have any questions or comments.

Warranty and Limitations of Liability

WARRANTY

OMRON's exclusive warranty is that the products are free from defects in materials and workmanship for a period of one year (or other period if specified) from date of sale by OMRON.

OMRON MAKES NO WARRANTY OR REPRESENTATION, EXPRESS OR IMPLIED, REGARDING NON-INFRINGEMENT, MERCHANTABILITY, OR FITNESS FOR PARTICULAR PURPOSE OF THE PRODUCTS. ANY BUYER OR USER ACKNOWLEDGES THAT THE BUYER OR USER ALONE HAS DETERMINED THAT THE PRODUCTS WILL SUITABLY MEET THE REQUIREMENTS OF THEIR INTENDED USE. OMRON DISCLAIMS ALL OTHER WARRANTIES, EXPRESS OR IMPLIED.

LIMITATIONS OF LIABILITY

OMRON SHALL NOT BE RESPONSIBLE FOR SPECIAL, INDIRECT, OR CONSEQUENTIAL DAMAGES, LOSS OF PROFITS OR COMMERCIAL LOSS IN ANY WAY CONNECTED WITH THE PRODUCTS, WHETHER SUCH CLAIM IS BASED ON CONTRACT, WARRANTY, NEGLIGENCE, OR STRICT LIABILITY.

In no event shall the responsibility of OMRON for any act exceed the individual price of the product on which liability is asserted.

IN NO EVENT SHALL OMRON BE RESPONSIBLE FOR WARRANTY, REPAIR, OR OTHER CLAIMS REGARDING THE PRODUCTS UNLESS OMRON'S ANALYSIS CONFIRMS THAT THE PRODUCTS WERE PROPERLY HANDLED, STORED, INSTALLED, AND MAINTAINED AND NOT SUBJECT TO CONTAMINATION, ABUSE, MISUSE, OR INAPPROPRIATE MODIFICATION OR REPAIR.

Application Considerations

SUITABILITY FOR USE

OMRON shall not be responsible for conformity with any standards, codes, or regulations that apply to the combination of products in the customer's application or use of the products.

At the customer's request, OMRON will provide applicable third party certification documents identifying ratings and limitations of use that apply to the products. This information by itself is not sufficient for a complete determination of the suitability of the products in combination with the end product, machine, system, or other application or use.

The following are some examples of applications for which particular attention must be given. This is not intended to be an exhaustive list of all possible uses of the products, nor is it intended to imply that the uses listed may be suitable for the products:

- Outdoor use, uses involving potential chemical contamination or electrical interference, or conditions or uses not described in this manual.
- Nuclear energy control systems, combustion systems, railroad systems, aviation systems, medical equipment, amusement machines, vehicles, safety equipment, and installations subject to separate industry or government regulations.
- Systems, machines, and equipment that could present a risk to life or property.

Please know and observe all prohibitions of use applicable to the products.

NEVER USE THE PRODUCTS FOR AN APPLICATION INVOLVING SERIOUS RISK TO LIFE OR PROPERTY WITHOUT ENSURING THAT THE SYSTEM AS A WHOLE HAS BEEN DESIGNED TO ADDRESS THE RISKS, AND THAT THE OMRON PRODUCTS ARE PROPERLY RATED AND INSTALLED FOR THE INTENDED USE WITHIN THE OVERALL EQUIPMENT OR SYSTEM.

PROGRAMMABLE PRODUCTS

OMRON shall not be responsible for the user's programming of a programmable product, or any consequence thereof.

Disclaimers

CHANGE IN SPECIFICATIONS

Product specifications and accessories may be changed at any time based on improvements and other reasons.

It is our practice to change model numbers when published ratings or features are changed, or when significant construction changes are made. However, some specifications of the products may be changed without any notice. When in doubt, special model numbers may be assigned to fix or establish key specifications for your application on your request. Please consult with your OMRON representative at any time to confirm actual specifications of purchased products.

DIMENSIONS AND WEIGHTS

Dimensions and weights are nominal and are not to be used for manufacturing purposes, even when tolerances are shown.

PERFORMANCE DATA

Performance data given in this manual is provided as a guide for the user in determining suitability and does not constitute a warranty. It may represent the result of OMRON's test conditions, and the users must correlate it to actual application requirements. Actual performance is subject to the OMRON Warranty and Limitations of Liability.

ERRORS AND OMISSIONS

The information in this manual has been carefully checked and is believed to be accurate; however, no responsibility is assumed for clerical, typographical, or proofreading errors, or omissions.

Safety Precautions

Definition of Precautionary Information

The following notation is used in this manual to provide precautions required to ensure safe usage of an NJ-series Controller. The safety precautions that are provided are extremely important to safety. Always read and heed the information provided in all safety precautions.

The following notation is used.

 WARNING	Indicates a potentially hazardous situation which, if not avoided, could result in death or serious injury. Additionally, there may be severe property damage.
--	--

 Caution	Indicates a potentially hazardous situation which, if not avoided, may result in minor or moderate injury, or property damage.
--	--



Precautions for Safe Use

Indicates precautions on what to do and what not to do to ensure safe usage of the product.



Precautions for Correct Use

Indicates precautions on what to do and what not to do to ensure proper operation and performance.

Symbols



The circle and slash symbol indicates operations that you must not do. The specific operation is shown in the circle and explained in text. This example indicates prohibiting disassembly.



The triangle symbol indicates precautions (including warnings). The specific operation is shown in the triangle and explained in text. This example indicates a precaution for electric shock.



The triangle symbol indicates precautions (including warnings). The specific operation is shown in the triangle and explained in text. This example indicates a general precaution.



The filled circle symbol indicates operations that you must do. The specific operation is shown in the circle and explained in text. This example shows a general precaution for something that you must do.

WARNING

During Power Supply

Do not touch any of the terminals or terminal blocks while the power is being supplied. Doing so may result in electric shock.



Do not attempt to take any Unit apart. In particular, high-voltage parts are present in the Power Supply Unit while power is supplied or immediately after power is turned OFF. Touching any of these parts may result in electric shock. There are sharp parts inside the Unit that may cause injury.



Fail-safe Measures

Provide safety measures in external circuits to ensure safety in the system if an abnormality occurs due to malfunction of the CPU Unit, other Units, or slaves or due to other external factors affecting operation. Not doing so may result in serious accidents due to incorrect operation.



Emergency stop circuits, interlock circuits, limit circuits, and similar safety measures must be provided in external control circuits.



The Controller outputs may remain ON or OFF due to deposition or burning of the output relays or destruction of the output transistors. As a countermeasure for such problems, external safety measures must be provided to ensure safe operation of the system.



The CPU Unit will turn OFF all outputs from Basic Output Units in the following cases.

- If an error occurs in the power supply
- If the power supply connection becomes faulty
- If a CPU watchdog timer error or CPU reset occurs
- If a major fault level Controller error occurs
- While the CPU Unit is on standby until RUN mode is entered after the power is turned ON



External safety measures must be provided to ensure safe operation of the system even if the outputs turn OFF.

If external power supplies for slaves or other devices are overloaded or short-circuited, the voltage will drop, outputs will turn OFF, and the system may be unable to read inputs. Provide external safety measures in controls with monitoring of external power supply voltage as required so that the system operates safely in such a case.



WARNING

Fail-safe Measures

Unintended outputs may occur when an error occurs in variable memory or in memory used for CJ-series Units. As a countermeasure for such problems, external safety measures must be provided to ensure safe operation of the system.



Provide measures in the communications system and user program to ensure safety in the overall system even if errors or malfunctions occur in data link communications or remote I/O communications.



If there is interference in remote I/O communications or if a major fault level error occurs, output status will depend on the products that are used. Confirm the operation that will occur when there is interference in communications or a major fault level error, and implement safety measures. Correctly set all of the EtherCAT slaves.



The NJ-series Controller continues normal operation for a certain period of time when a momentary power interruption occurs. This means that the NJ-series Controller may receive incorrect signals from external devices that are also affected by the power interruption. Accordingly, take suitable actions, such as external fail-safe measures and interlock conditions, to monitor the power supply voltage of the external device as required.



You must take fail-safe measures to ensure safety in the event of incorrect, missing, or abnormal signals caused by broken signal lines, momentary power interruptions, or other causes. Not doing so may result in serious accidents due to incorrect operation.



Voltage and Current Inputs

Make sure that the voltages and currents that are input to the Units and slaves are within the specified ranges. Inputting voltages or currents that are outside of the specified ranges may cause accidents or fire.



Downloading

Always confirm safety at the destination before you transfer a user program, configuration data, setup data, device variables, or values in memory used for CJ-series Units from the Sysmac Studio. The devices or machines may perform unexpected operation regardless of the operating mode of the CPU Unit.



Caution

Application

Do not touch any Unit when power is being supplied or immediately after the power supply is turned OFF. Doing so may result in burn injury.



Wiring

Be sure that all terminal screws and cable connector screws are tightened to the torque specified in the relevant manuals. The loose screws may result in fire or malfunction.



Online Editing

Execute online editing only after confirming that no adverse effects will be caused by deviations in the timing of I/O. If you perform online editing, the task execution time may exceed the task period, I/O may not be refreshed with external devices, input signals may not be read, and output timing may change.



Precautions for Safe Use

Disassembly and Dropping

- Do not attempt to disassemble, repair, or modify any Units. Doing so may result in malfunction or fire.
- Do not drop any Unit or subject it to abnormal vibration or shock. Doing so may result in Unit malfunction or burning.

Mounting

- The sliders on the tops and bottoms of the Power Supply Unit, CPU Unit, I/O Units, Special I/O Unit, and CPU Bus Units must be completely locked (until they click into place) after connecting the adjacent Unit connectors.

Installation

- Always connect to a ground of 100 Ω or less when installing the Units. A ground of 100 Ω or less must be installed when shorting the GR and LG terminals on the Power Supply Unit.

Wiring

- Follow the instructions in this manual to correctly perform wiring.
Double-check all wiring and switch settings before turning ON the power supply.
- Use crimp terminals for wiring.
Do not connect bare stranded wires directly to terminals.
- Do not pull on the cables or bend the cables beyond their natural limit.
Do not place heavy objects on top of the cables or other wiring lines. Doing so may break the cables.
- Mount terminal blocks and connectors only after checking the mounting location carefully.
- Be sure that the terminal blocks, expansion cables, and other items with locking devices are properly locked into place.
- Always remove any dust proof labels that are on the top of the Units when they are shipped before you turn ON the power supply. If the labels are not removed, heat will accumulate and malfunctions may occur.
- Before you connect a computer to the CPU Unit, disconnect the power supply plug of the computer from the AC outlet. Also, if the computer has an FG terminal, make the connections so that the FG terminal has the same electrical potential as the FG (GR) terminal on the Power Supply Unit. A difference in electric potential between the computer and Controller may cause failure or malfunction.
- If the external power supply to an Output Unit or slave has polarity, connect it with the correct polarity. If the polarity is reversed, current may flow in the reverse direction and damage the connected devices regardless of the operation of the Controller.

Power Supply Design

- Do not exceed the rated supply capacity of the Power Supply Units in the NJ-series Controller. The rated supply capacities are given in the *NJ-series CPU Unit Hardware User's Manual* (Cat. No. W500).
If the capacity is exceeded, operation may stop, malfunctions may occur, or data may not be backed up normally for power interruptions.
Use NJ-series Power Supply Units for both the NJ-series CPU Rack and Expansion Racks.
Operation is not possible if a CJ-series Power Supply Unit is used with an NJ-series CPU Unit or an NJ-series Power Supply Unit is used with a CJ-series CPU Unit.

- Do not apply voltages or connect loads to the Output Units or slaves in excess of the maximum ratings.
- Surge current occurs when the power supply is turned ON. When selecting fuses or breakers for external circuits, consider the above precaution and allow sufficient margin in shut-off performance. Refer to the relevant manuals for surge current specifications. Refer to the *NJ-series CPU Unit Hardware User's Manual* (Cat. No. W500) for surge current specifications.
- If the full dielectric strength voltage is applied or turned OFF using the switch on the tester, the generated impulse voltage may damage the Power Supply Unit. Use the adjustment on the tester to gradually increase and decrease the voltage.
- Apply the voltage between the Power Supply Unit's L1 or L2 terminal and the GR terminal when testing insulation and dielectric strength. You do not have to disconnect the LG and GR terminals to perform these tests.
- Do not supply AC power from an inverter or other device with a square-wave output. Internal temperature rise may result in smoking or burning. Always input a sinusoidal wave with the frequency that is given in the *NJ-series CPU Unit Hardware User's Manual* (Cat. No. W500).
- Install external breakers and take other safety measures against short-circuiting in external wiring.

Turning ON the Power Supply

- It takes up to approximately 10 to 20 s to enter RUN mode after the power is turned ON. During that time, outputs will be OFF or will be the values specified in the Unit or slave settings, and external communications cannot be performed. Use the RUN output on the Power Supply Unit, for example, to implement fail-safe circuits so that external devices do not operate incorrectly.
- Configure the external circuits so that the power supply to the control system turns ON only after the power supply to the Controller has turned ON. If the power supply to the Controller is turned ON after the control power supply, temporary errors may result in incorrect control system signals because the output terminals on Output Units may momentarily turn ON when power supply is turned ON to the Controller.

Actual Operation

- Check the user program, data, and parameter settings for proper execution before you use them for actual operation.

Turning OFF the Power Supply

- Never turn OFF the power supply to the Controller when the BUSY indicator is flashing. While the BUSY indicator is lit, the user program and settings in the CPU Unit are being backed up in the built-in non-volatile memory. This data will not be backed up correctly if the power supply is turned OFF. Also, a major fault level Controller error will occur the next time you start operation, and operation will stop.
- Do not turn OFF the power supply or remove the SD Memory Card while SD Memory Card access is in progress (i.e., while the SD BUSY indicator flashes). Data may become corrupted, and the Controller will not operate correctly if it uses corrupted data. To remove the SD Memory Card from the CPU Unit while the power supply is ON, press the SD Memory Card power supply switch and wait for the SD BUSY indicator to turn OFF before you remove the SD Memory Card.
- Do not disconnect the cable or turn OFF the power supply to the Controller when downloading data or the user program from Support Software.
- Always turn OFF the power supply to the Controller before you attempt any of the following.
 - Mounting or removing I/O Units or the CPU Unit
 - Assembling the Units
 - Setting DIP switches or rotary switches
 - Connecting cables or wiring the system
 - Connecting or disconnecting the connectors

The Power Supply Unit may continue to supply power to the rest of the Controller for a few seconds after the power supply turns OFF. The PWR indicator is lit during this time. Confirm that the PWR indicator is not lit before you perform any of the above.

Operation

- Confirm that no adverse effect will occur in the system before you attempt any of the following.
 - Changing the operating mode of the CPU Unit (including changing the setting of the Operating Mode at Startup)
 - Changing the user program or settings
 - Changing set values or present values
 - Forced refreshing
- Always sufficiently check the safety at the connected devices before you change the settings of an EtherCAT slave or Special Unit.
- If two different function modules are used together, such as when you use CJ-series Basic Output Units and EtherCAT slave outputs, take suitable measures in the user program and external controls to ensure that safety is maintained in the controlled system if one of the function modules stops. The relevant outputs will stop if a partial fault level error occurs in one of the function modules.
- Always confirm safety at the connected equipment before you reset Controller errors with an event level of partial fault or higher for the EtherCAT Master Function Module.
When the error is reset, all slaves that were in any state other than Operational state due to a Controller error with an event level of partial fault or higher (in which outputs are disabled) will go to Operational state and the outputs will be enabled.
Before you reset all errors, confirm that no Controller errors with an event level of partial fault have occurred for the EtherCAT Master Function Module.
- Always confirm safety at the connected equipment before you reset Controller errors for a CJ-series Special Unit. When a Controller error is reset, the Unit where the Controller error with an event level of observation or higher will be restarted.
Before you reset all errors, confirm that no Controller errors with an event level of observation or higher have occurred for the CJ-series Special Unit. Observation level events do not appear on the Controller Error Tab Page, so it is possible that you may restart the CJ-series Special Unit without intending to do so.
You can check the status of the `_CJB_UnitErrSta[0,0]` to `_CJB_UnitErrSta[3,9]` error status variables on a Watch Tab Page to see if an observation level Controller error has occurred.

Battery Backup

- The user program and initial values for the variables are stored in non-volatile memory in the CPU Unit. The present values of variables with the Retain attribute and the values of the Holding, DM, and EM Areas in the memory used for CJ-series Units are backed up by a Battery. If the Battery is not connected or the Battery is exhausted, the CPU Unit detects a Battery-backup Memory Check Error. If that error is detected, variables with a Retain attribute are set to their initial values and the Holding, DM, and EM Areas in memory used for CJ-series Units are cleared to all zeros. Perform thorough verifications and provide sufficient measures to ensure that the devices perform safe operation for the initial values of the variables with Retain attributes and the resulting operation.

Debugging

- Forced refreshing ignores the results of user program execution and refreshes I/O with the specified values. If forced refreshing is used for inputs for which I/O refreshing is not supported, the inputs will first take the specified values, but they will then be overwritten by the user program. This operation differs from the force-set/reset functionality of the CJ-series PLCs.

- You cannot upload or download information for forced refreshing with the Sysmac Studio. After downloading data that contains forced refreshing, change to RUN mode and then use the Sysmac Studio to perform the operation for forced refreshing. Depending on the difference in the forced status, the control system may operate unexpectedly.
- Do not specify the same address for the AT specification for more than one variable. Doing so would allow the same entity to be accessed with different variable names, which would make the user program more difficult to understand and possibly cause programming mistakes.

General Communications

- When you use data link communications, check the error information given in the status flags to make sure that no error has occurred in the source device. Write the user program to use the received data only if there is no error. If there is an error in the source device, the data for the data link may contain incorrect values.
- Unexpected operation may result if inappropriate data link tables are set. Even if appropriate data link tables have been set, confirm that the controlled system will not be adversely affected before you transfer the data link tables. The data links start automatically after the data link tables are transferred.
- All CPU Bus Units are restarted when routing tables are transferred from Support Software to the CPU Unit. Restarting these Units is required to read and enable the new routing tables. Confirm that the system will not be adversely affected by restarting before you transfer the routing tables.
- Tag data links will stop between related nodes while tag data link parameters are transferred during Controller operation. Confirm that the system will not be adversely affected before you transfer the tag data link parameters.

EtherNet/IP Communications

- All related EtherNet/IP nodes are reset when you transfer settings for the built-in EtherNet/IP port (including IP addresses and tag data links settings). This is performed to read and enable the settings. Confirm that the system will not be adversely affected by resetting nodes before you transfer the settings.
- If EtherNet/IP tag data links (cyclic communications) are used with a repeating hub, the communications load on the network will increase. This will increase collisions and may prevent stable communications. Do not use repeating hubs on networks where tag data links are used. Use an Ethernet switch instead.

EtherCAT Communications

- Make sure that the communications distance, number of nodes connected, and method of connection for EtherCAT are within specifications. Do not connect EtherCAT communications to EtherNet/IP, a standard in-house LAN, or other networks. An overload may cause the network to fail or malfunction.
- Malfunctions or unexpected operation may occur for some combinations of EtherCAT revisions of the master and slaves. If you disable the revision check in the network settings, use the Sysmac Studio to check the slave revision settings in the master and the actual slave revisions, and then make sure that functionality is compatible in the slave manuals or other references. You can check the actual slave revisions from the Sysmac Studio or on slave nameplates.
- After you transfer the user program, the CPU Unit is restarted. Communications with the EtherCAT slaves are cut off for up to 45 seconds. During that period, the slave outputs behave according to the slave settings. Before you transfer the user program, confirm that the system will not be adversely affected.
- If the Fail-soft Operation parameter is set to stop operation, process data communications will stop for all slaves when an EtherCAT communications error is detected in a slave. For this reason, if Servo Drives are connected, the Servos for all axes will be turned OFF. Make sure that the Fail-soft Operation parameter setting results in safe operation when a device error occurs.

- EtherCAT communications are not always established immediately after the power supply is turned ON. Use the system-defined variables in the user program to confirm that communications are established before attempting control operations.
- If frames sent to EtherCAT slaves are lost due to noise or other causes, slave I/O data is not communicated, and the intended operation is sometimes not achieved. If noise countermeasures are required, use the `_EC_InDataInvalid` (Input Data Disable) system-defined variable as an interlock condition in the user program.
Refer to the *NJ-series CPU Unit Built-in EtherCAT Port User's Manual* (Cat. No. W505) for details. The slave outputs behave according to the slave settings. Refer to the manuals for the slaves for details.
- When an EtherCAT slave is disconnected, communications will stop and control of the outputs will be lost not only for the disconnected slave, but for all slaves connected after it. Confirm that the system will not be adversely affected before you disconnect a slave.
- If you disconnect the cable from an EtherCAT slave to disconnect it from the network, any current communications frames may be lost. If frames are lost, slave I/O data is not communicated, and the intended operation is sometimes not achieved. Perform the following processing for a slave that needs to be replaced.
 - Program the `_EC_InDataInvalid` (Input Data Disable) system-defined variable as an interlock condition.
 - Set the Impermissible Number of Continuous Timeouts setting in the EtherCAT master to at least 2.
 Refer to the *NJ-series CPU Unit Built-in EtherCAT Port User's Manual* (Cat. No. W505) for details.

Motion Control

- Confirm the axis number carefully before you perform an MC Test Run.
- The motor is stopped if communications are interrupted between the Sysmac Studio and the CPU Unit during an MC Test Run. Connect the communications cable between the computer and CPU Unit securely and confirm that the system will not be adversely affected before you perform an MC Test Run.
- Always execute the Save Cam Table instruction if you change any of the cam data from the user program in the CPU Unit or from the Sysmac Studio. If the cam data is not saved, the previous condition will be restored when the power is turned ON again, possibly causing unexpected machine operation.
- The positive drive prohibit input (POT), negative drive prohibit input (NOT), and home proximity input (DEC) of the Servo Drive are used by the MC Function Module as the positive limit input, negative limit input, and home proximity input. Make sure that the signal widths for all of these input signals are longer than the control period of the MC Function Module. If the input signal widths are shorter than the control period, the MC Function Module may not be able to detect the input signals, resulting in incorrect operation.

Battery Replacement

- The Battery may leak, rupture, heat, or ignite. Never short-circuit, charge, disassemble, heat, or incinerate the Battery or subject it to strong shock.
- Dispose of any Battery that has been dropped on the floor or otherwise subjected to excessive shock. Batteries that have been subjected to shock may leak if they are used.
- UL standards require that only an experienced engineer replace the Battery. Make sure that an experienced engineer is in charge of Battery replacement.
- Apply power for at least five minutes before changing the Battery. Install a new Battery within five minutes (at 25°C) of turning OFF the power supply. If power is not supplied for at least 5 minutes, the saved data may be lost.

Unit Replacement

- We recommend replacing the Battery with the power turned OFF to prevent the CPU Unit's sensitive internal components from being damaged by static electricity and to prevent malfunctions. The Battery can be replaced without turning OFF the power supply. To do so, always touch a grounded piece of metal to discharge static electricity from your body before you start the procedure. After you replace the Battery, connect the Sysmac Studio and clear the Low Battery Voltage error.
- Make sure that the required data, including the user program, configurations, settings, variables, and memory used for CJ-series Units, is transferred to a CPU Unit that was replaced and to externally connected devices before restarting operation.
Be sure to include the routing tables, network parameters, and other CPU Bus Unit data, which are stored in the CPU Unit.

Disposal

- Dispose of the product and Batteries according to local ordinances as they apply.



廢電池請回收

- The following information must be displayed for all products that contain primary lithium batteries with a perchlorate content of 6 ppb or higher when shipped to or transported through the State of California, USA.
Perchlorate Material - special handling may apply.
See www.dtsc.ca.gov/hazardouswaste/perchlorate.
- The CPU Unit contains a primary lithium battery with a perchlorate content of 6 ppb or higher. Place the above information on the individual boxes and shipping boxes when shipping finished products that contain a CPU Unit to the State of California, USA.

Precautions for Correct Use

Storage, Mounting, and Wiring

- Do not operate or store the Controller in the following locations. Operation may stop or malfunctions may occur.
 - Locations subject to direct sunlight
 - Locations subject to temperatures or humidity outside the range specified in the specifications
 - Locations subject to condensation as the result of severe changes in temperature
 - Locations subject to corrosive or flammable gases
 - Locations subject to dust (especially iron dust) or salts
 - Locations subject to exposure to water, oil, or chemicals
 - Locations subject to shock or vibration
- Take appropriate and sufficient countermeasures when installing the Controller in the following locations.
 - Locations subject to strong, high-frequency noise
 - Locations subject to static electricity or other forms of noise
 - Locations subject to strong electromagnetic fields
 - Locations subject to possible exposure to radioactivity
 - Locations close to power lines
- Before touching a Unit, be sure to first touch a grounded metallic object in order to discharge any static build-up.
- Install the Controller away from sources of heat and ensure proper ventilation. Not doing so may result in malfunction, in operation stopping, or in burning.
- An I/O bus check error will occur and the Controller will stop if an I/O Connecting Cable's connector is disconnected from the Rack. Be sure that the connectors are secure.
- Do not allow foreign matter to enter the openings in the Unit. Doing so may result in Unit burning, electric shock, or failure.
- Do not allow wire clippings, shavings, or other foreign material to enter any Unit. Otherwise, Unit burning, failure, or malfunction may occur. Cover the Units or take other suitable countermeasures, especially during wiring work.
- For EtherCAT and EtherNet/IP, use the connection methods and cables that are specified in the *NJ-series CPU Unit Built-in EtherCAT Port User's Manual* (Cat. No. W505) and the *NJ-series CPU Unit Built-in EtherNet/IP Port User's Manual* (Cat. No. W506). Otherwise, communications may be faulty.
- Use the rated power supply voltage for the Power Supply Units. Take appropriate measures to ensure that the specified power with the rated voltage and frequency is supplied in places where the power supply is unstable.
- Make sure that the current capacity of the wire is sufficient. Otherwise, excessive heat may be generated. When cross-wiring terminals, the total current for all the terminals will flow in the wire. When wiring cross-overs, make sure that the current capacity of each of the wires is not exceeded.
- Do not touch the terminals on the Power Supply Unit immediately after turning OFF the power supply. Residual voltage may cause electrical shock.
- If you use reed switches for the input contacts for AC Input Units, use switches with a current capacity of 1 A or greater.
If the capacity of the reed switches is too low, surge current may fuse the contacts.

Error Processing

- In applications that use the results of instructions that read the error status, consider the affect on the system when errors are detected and program error processing accordingly. For example, even the detection of a minor error, such as Battery replacement during operation, can affect the system depending on how the user program is written.

Unit Replacement

- If you replace a CPU Bus Unit or Special I/O Unit, refer to operation manual for the Unit for information on the data required for individual Units and redo the necessary settings.
- The absolute encoder home offset is backed up with a Battery in the CPU Unit.
When you change the combination of the CPU Unit and Servomotor, e.g., when you add or replace a Servomotor, define home again.
To restore the information without changing the CPU Unit-Servomotor combination, remove the absolute encoder home offset from the data to restore.

Task Settings

- If a Task Period Exceeded error occurs, shorten the programs to fit in the task period or increase the setting of the task period.

Motion Control

- Use the system-defined variable in the user program to confirm that EtherCAT communications are established before you attempt to execute motion control instructions. Motion control instructions are not executed normally if EtherCAT communications are not established.
- Use the system-defined variables to monitor for errors in communications with the slaves that are controlled by the motion control function module. Motion control instructions are not executed normally if an error occur in slave communications.
- Before you start an MC Test Run, make sure that the operation parameters are set correctly.
- Do not download motion control settings during an MC Test Run.

EtherCAT Communications

- Do not disconnect the EtherCAT slave cables during operation. The outputs will become unstable.
- Set the Servo Drives to stop operation if an error occurs in EtherCAT communications between the Controller and a Servo Drive.

Battery Replacement

- Be sure to install a replacement Battery within two years of the production date shown on the Battery label.
- Turn ON the power after replacing the Battery for a CPU Unit that has been unused for a long time. Leaving the CPU Unit unused again without turning ON the power even once after the Battery is replaced may result in a shorter Battery life.
- When you replace the Battery, use the CJ1W-BAT01 Battery Set.

SD Memory Cards

- Insert the SD Memory Card all the way.
- Do not turn OFF the power supply to the Controller during SD Memory Card access. The files may be corrupted.

If there is a corrupted file in the SD Memory Card, the file is automatically deleted by the restoration function when the power supply is turned ON.

Regulations and Standards

Conformance to EC Directives

Applicable Directives

- EMC Directives
- Low Voltage Directive

Concepts

● EMC Directive

OMRON devices that comply with EC Directives also conform to the related EMC standards so that they can be more easily built into other devices or the overall machine. The actual products have been checked for conformity to EMC standards.*

Whether the products conform to the standards in the system used by the customer, however, must be checked by the customer. EMC-related performance of the OMRON devices that comply with EC Directives will vary depending on the configuration, wiring, and other conditions of the equipment or control panel on which the OMRON devices are installed. The customer must, therefore, perform the final check to confirm that devices and the overall machine conform to EMC standards.

* Applicable EMC (Electromagnetic Compatibility) standards are as follows:

EMS (Electromagnetic Susceptibility): EN 61131-2 and EN 61000-6-2

EMI (Electromagnetic Interference): EN 61131-2 and EN 61000-6-4 (Radiated emission: 10-m regulations)

● Low Voltage Directive

Always ensure that devices operating at voltages of 50 to 1,000 VAC and 75 to 1,500 VDC meet the required safety standards. The applicable directive is EN 61131-2.

● Conformance to EC Directives

The NJ-series Controllers comply with EC Directives. To ensure that the machine or device in which the NJ-series Controller is used complies with EC Directives, the Controller must be installed as follows:

- The NJ-series Controller must be installed within a control panel.
- You must use reinforced insulation or double insulation for the DC power supplies connected to DC Power Supply Units and I/O Units.
- NJ-series Controllers that comply with EC Directives also conform to the Common Emission Standard (EN 61000-6-4). Radiated emission characteristics (10-m regulations) may vary depending on the configuration of the control panel used, other devices connected to the control panel, wiring, and other conditions.

You must therefore confirm that the overall machine or equipment complies with EC Directives.

Conformance to Shipbuilding Standards

The NJ-series Controllers comply with the following shipbuilding standards. Applicability to the shipbuilding standards is based on certain usage conditions. It may not be possible to use the product in some locations. Contact your OMRON representative before attempting to use a Controller on a ship.

Usage Conditions for NK and LR Shipbuilding Standards

- The NJ-series Controller must be installed within a control panel.
- Gaps in the door to the control panel must be completely filled or covered with gaskets or other material.
- The following noise filter must be connected to the power supply line.

Noise Filter

Manufacturer	Model
Cosel Co., Ltd.	TAH-06-683

Trademarks

- Sysmac and SYSMAC are trademarks or registered trademarks of OMRON Corporation in Japan and other countries for OMRON factory automation products.
- Windows, Windows 98, Windows XP, Windows Vista, and Windows 7 are registered trademarks of Microsoft Corporation in the USA and other countries.
- EtherCAT® is a registered trademark of Beckhoff Automation GmbH for their patented technology.
- The SD logo is a trademark of SD-3C, LLC. 

Other company names and product names in this document are the trademarks or registered trademarks of their respective companies.

Unit Versions

Unit Versions

A “unit version” has been introduced to manage CPU Units in the NJ Series according to differences in functionality accompanying Unit upgrades.

Notation of Unit Versions on Products

The unit version is given on the ID information label of the products for which unit versions are managed, as shown below.

Example for NJ-series NJ501-□□□□ CPU Unit:

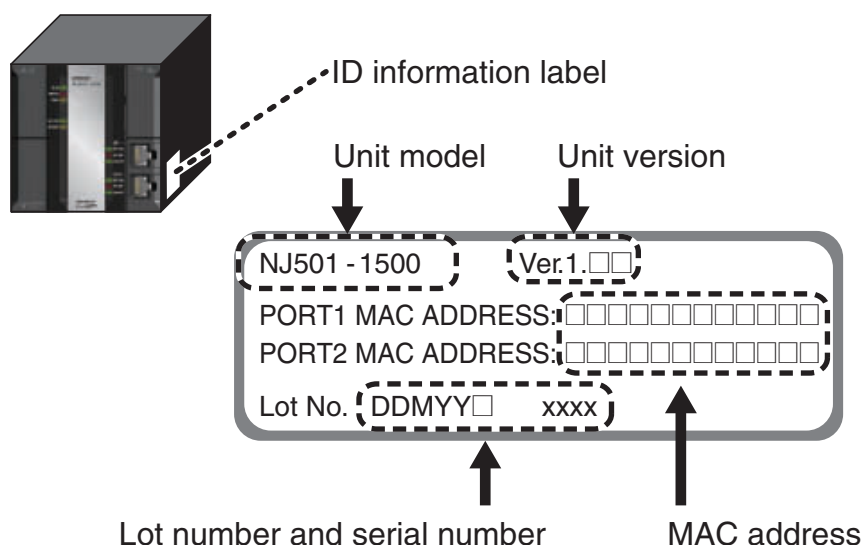

The following information is provided on the ID information label.

Item	Description
Unit model	Gives the model of the Unit.
Unit version	Gives the unit version of the Unit.
Lot number and serial number	Gives the lot number and serial number of the Unit. DDMY□: Lot number, □: For use by OMRON, xxxx: Serial number “M” gives the month (1 to 9: January to September, X: October, Y: November, Z: December)
MAC address	Gives the MAC address of the built-in port on the Unit.

Confirming Unit Versions with Sysmac Studio

You can use the Unit Production Information on the Sysmac Studio to check the unit version of the CPU Unit, CJ-series Special I/O Units, CJ-series CPU Bus Units, and EtherCAT slaves. The unit versions of CJ-series Basic I/O Units cannot be checked from the Sysmac Studio.

● CPU Unit and CJ-series Units

- 1 Double-click **CPU/Expansion Racks** under **Configurations and Setup** in the Multiview Explorer. Or, right-click **CPU/Expansion Racks** under **Configurations and Setup** and select **Edit** from the menu.

The Unit Editor is displayed for the Controller Configurations and Setup layer.

- Right-click any open space in the Unit Editor and select **Production Information**.
The Production Information Dialog Box is displayed.

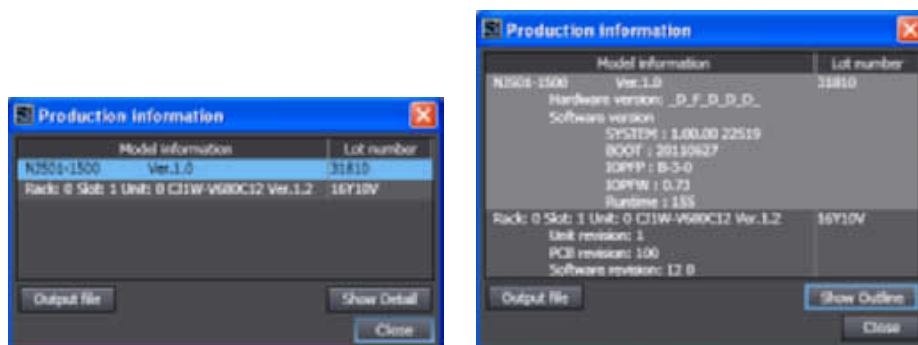

Simple Display

Detailed Display

In this example, “Ver.1.0” is displayed next to the unit model.

The following items are displayed.

CPU Unit	CJ-series Units
Unit model	Unit model
Unit version	Unit version
Lot number	Lot number
	Rack number, slot number, and unit number

● EtherCAT Slaves

- Double-click **EtherCAT** under **Configurations and Setup** in the Multiview Explorer. Or, right-click **EtherCAT** under **Configurations and Setup** and select **Edit** from the menu.

The EtherCAT Configuration Tab Page is displayed for the Controller Configurations and Setup layer.

- Right-click the master in the EtherCAT Configurations Editing Pane and select **Display Production Information**.

The Production Information Dialog Box is displayed.

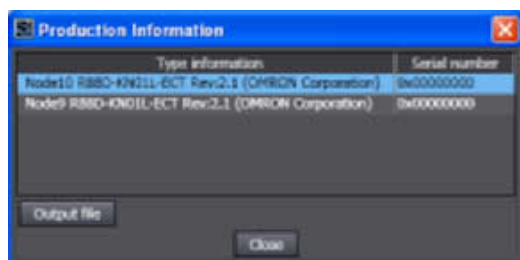

The following items are displayed.

- Node address
- Type information*
- Serial number

* If the model number cannot be determined (such as when there is no ESI file), the vendor ID, product code, and revision number are displayed.

Related Manuals

The following manuals are related to the NJ-series Controllers. Use these manuals for reference.

Manual name	Cat. No.	Model numbers	Application	Description
NJ-series CPU Unit Hardware User's Manual	W500	NJ501-□□□□	Learning the basic specifications of the NJ-series CPU Units, including introductory information, designing, installation, and maintenance. Mainly hardware information is provided.	An introduction to the entire NJ-series system is provided along with the following information on a Controller built with an NJ501 CPU Unit. <ul style="list-style-type: none"> • Features and system configuration • Introduction • Part names and functions • General specifications • Installation and wiring • Maintenance and inspection Use this manual together with the <i>NJ-series CPU Unit Software User's Manual</i> (Cat. No. W501).
NJ-series CPU Unit Software User's Manual	W501	NJ501-□□□□	Learning how to program and set up an NJ-series CPU Unit. Mainly software information is provided.	The following information is provided on a Controller built with an NJ501 CPU Unit. <ul style="list-style-type: none"> • CPU Unit operation • CPU Unit features • Initial settings • Programming based on IEC 61131-3 language specifications Use this manual together with the <i>NJ-series CPU Unit Hardware User's Manual</i> (Cat. No. W500).
Sysmac Studio Version 1 Operation Manual	W504	SYSMAC-SE2□□□	Learning about the operating procedures and functions of the Sysmac Studio.	Describes the operating procedures of the Sysmac Studio.
CJ-series 4-Channel Counter Unit Operation Manual for NJ-series CPU Unit (This Manual)	W512)	CJ1W-CTL41-E	Learning about the functions and usage of CJ-series 4-Channel Counter Units for using it in an NJ-series configuration.	The functions and usage of the CJ-series 4-Channel Counter Unit for using it in an NJ-series configuration as described.
CJ-series 4-Channel Counter Uni Operation Manual	W02E-EN-01	CJ1W-CTL41-E	Learning about the functions and usage of CJ-series 4-Channel Counter Units for using it in a CJ-series configuration.	The functions and usage of the CJ-series 4-Channel Counter Unit for using it in an CJ-series configuration as described.

Revision History

A manual revision code appears as a suffix to the catalog number on the front and back covers of the manual.

Cat. No. W512-E2-01

↑
Revision code

Revision code	Date	Revised content
01	September 2011	Original production

1

Introduction

This section gives specifications of the CJ1W-CTL41-E and a brief description of the functions and features of the Unit and the areas of application.

1-1	Features and Functions	1-2
1-2	Basic Configuration	1-4
1-3	Specifications and Characteristics	1-6
1-3-1	General Specifications	1-6
1-3-2	Functional Specifications	1-6
1-3-3	Input Specifications	1-7
1-4	Quick Start Up Reference Guide	1-10
1-4-1	Configuring the Counter Unit	1-10
1-5	Operating Procedure Guidelines	1-12
1-6	Application Areas	1-14

1-1 Features and Functions

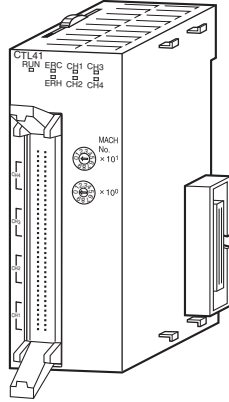

The CJ1W-CTL41-E, a Special I/O Unit, is a freely configurable 4-Channel Counter Unit. Depending on the requirements of your application, the specific behavior of the Unit can be adjusted by changing the configuration settings.

● CJ1W-CTL41-E Counters

The CJ1W-CTL41-E 4-Channel Counter Unit is equipped with 4 Counters and counts over a maximum binary range of 32-bits. Accepting input pulse frequencies of up to 100 kHz allows precise control of fast motions. The Unit's bi-directional counting ability allows movement detecting in either direction. Each Counter of the Unit can be configured independently. The Unit is equipped with 32 Software Outputs, each of which can be linked to Counter events.

● Counter Type

Configuring the Unit starts with choosing one out of two Counter Types:

- Circular Counter (refer to section 3-2-1 *Circular Counter*)
- Linear Counter (refer to section 3-2-2 *Linear Counter*)

By default each Counter is set to Circular Counter. For all Counter Types the full counting range is available. Circular and Linear Counters can be fully configured according to the application that is to be controlled.

● Input Signal Type

Depending on the type of input signal your application requires, every Counter allows a choice out of three input signal types:

- Phase Differential Inputs (multiplication by either 1, 2 or 4; refer to section 3-3-1 *Phase Differential*)
- Up/Down Pulse Inputs (refer to section 3-3-2 *Up & Down Pulse*)
- Pulse & Direction Inputs (refer to section 3-3-3 *Pulse & Direction*)

● Output Control Modes

To control the Software Outputs the Unit can be configured in one of the two following Output Control Modes:

- Range Mode (refer to section 3-5-1 *Range Mode*)
- Comparison Mode (refer to section 3-5-2 *Comparison Mode*)

In Range Mode, a configurable number of up to 4 Ranges can be applied to individual Counters. Every Range can control up to a maximum of 32 Software Outputs. An Output is turned ON when the Counter is in the corresponding Range.

In Comparison Mode a configurable number of up to 8 Comparison Values can be applied to individual Counters. Depending on the direction of counting, an Output can be set or reset (configurable) on reaching the Comparison Value. Every Comparison Value can control up to maximum 32 Outputs.

● **Resetting Counter Value**

Resetting of the Counter Value can be configured depending on the application needs. The following sources can trigger a reset:

- Software bit in the CPU
- Z-Input

To enable resetting a Counter Value, the Software Reset Enable bit can be used (refer to section 3-6 *Reset Signals*).

● **Hysteresis**

For Counters in Range Mode a hysteresis can be configured [1 to 255 counts], to prevent Outputs from toggling due to unwanted oscillating of encoding equipment (e.g. rotary incremental encoder). Refer to section 3-7-1 *Hysteresis*.

● **Noise Filtering**

For the purpose of suppressing noise on the signal lines A, B of every Counter, noise filters are provided. The cut-off frequencies for all signal lines A and B are fixed to 100 kHz.

● **Support Software**

The Unit can be configured by using Sysmac Studio.

● **Quick Start Up Reference Guide**

For a quick overview of all the features and functions the Counter Unit offers, refer to section 1-4 *Quick Start Up Reference Guide*. This section also contains references to the particular section(s) in the Manual where more detailed information about specific features and functions of the Counter Unit can be found.

1-2 Basic Configuration

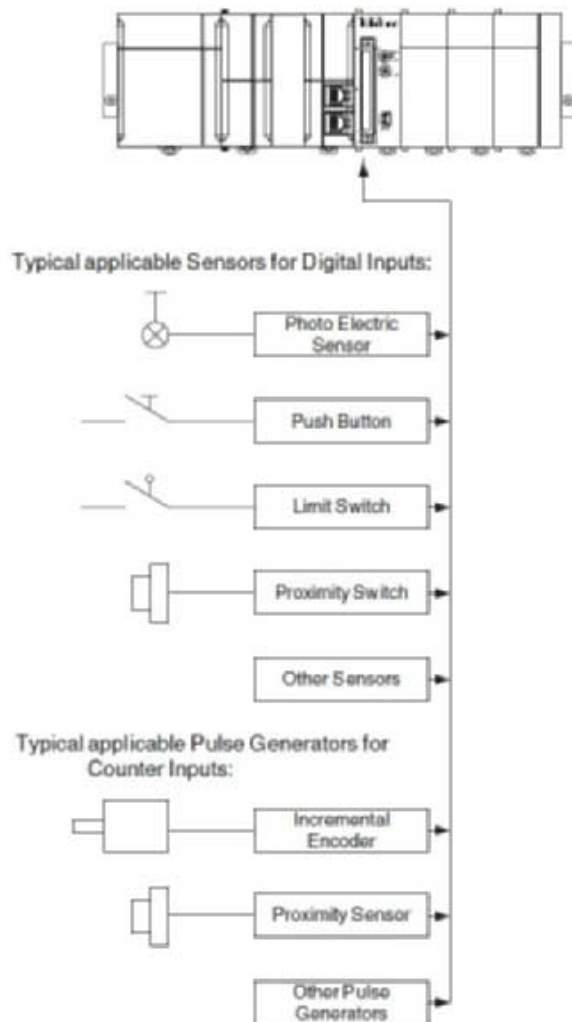

● Mounting Restrictions

The CJ1W-CTL41-E 4-Channel Counter Unit is a Special I/O Unit that belongs to the CJ Series.

The CJ1W-CT41-E 4-Channel Counter Unit can be mounted in an NJ-series CPU rack or NJ-series Expansion Rack.

The maximum number of CJ1W-CTL41-E 4-Channel Counter Units which can be mounted to a CJ CPU Rack or CJ Expansion Rack is equal to the number of slots of the Rack. In a configuration with multiple Racks, the maximum number of CJ1W-CTL41-E 4-Channel Counter Units is limited to 24.

Furthermore, the number of Counter Units that can be mounted to one Rack (i.e., a CPU Rack or Expansion Rack) depends on the maximum supply current from the Power Supply Unit that supplies the Rack and the current consumption of other Units on the Rack.

● I/O Connection Methods

To connect the Input signal wires to the Unit three methods are available.

- 1** Directly connecting the wires by soldering them to the external connector.

- 2** Indirectly connecting the wires by connecting them to screwless terminals on an XW2G-40G7-E Input Terminal Block Unit. This Input Terminal Block Unit allows connection of Line Driver or 24 V Encoder signals. The XW2G-40G7-E is connected to the Unit via standard available OMRON I/O-cables (XW2Z-xxxK).
- 3** Indirectly connecting the wires by connecting them to screw terminals on a standard XW2B-40G4, XW2B-40G5 or XW2D-40G6 OMRON Terminal Block Unit, i.e. the Terminal Block Unit is connected to the Unit via standard available OMRON I/O-cables (XW2Z-xxxK).

Refer to section 2-3-2 *Connector Wiring Methods* for more details.

1-3 Specifications and Characteristics

1-3-1 General Specifications

Item	CJ1W-CTL41-E
Unit type	Special I/O Unit
General Specifications	Conform to general specifications for NJ-series
Operating Temperature	0 to 55 °C
Storage Temperature	-20 to 70 °C
Humidity	10% to 90% without condensation
Internal Current Consumption	320 mA (at 5 V)
Dimensions (mm)	31 x 90 x 65 (W x H x D)
Weight	100 g
Mounting Position	NJ-series CPU Rack or NJ-series Expansion Rack
Maximum Number of CTL41-E Units per Rack	Equal to the number of slots of the Rack (see Note 1)
NJ system (CPU rack and expansion rack)	24
Data Exchange with CPU Unit	Data is exchanged through I/O ports, or as necessary memory for CJ-series Unit. For details, refer to 4-2 <i>Memory Allocation</i> .

Note 1 The maximum number of Units per Rack also depends on the maximum supply current of the Power Supply Unit and the current consumption of other Units on the Rack.

1-3-2 Functional Specifications

Item	CJ1W-CTL41-E
Number of Counters	4
Counter Type	<ul style="list-style-type: none"> • Circular Counter (refer to section 3-2-1 <i>Circular Counter</i>) • Linear Counter (refer to section 3-2-2 <i>Linear Counter</i>) The Counter Type can be selected by manipulating the appropriate Device Variable (refer to section 4-2-4 <i>Details of Device Variables for CJ-series Unit (for setting)</i>).
Maximum Input Frequency	100 kHz, refer to section 1-3-3 <i>Input Specifications</i> for details
Signals per Counter	Phase A, B and Z
Input Signal Types	<ul style="list-style-type: none"> • Phase Differential (multiplication x1), (multiplication x2) and (multiplication x4) (refer to section 3-3-1 <i>Phase Differential</i>) • Up/Down (refer to section 3-3-2 <i>Up & Down Pulse</i>) Pulse & Direction (refer to section 3-3-3 <i>Pulse & Direction</i>)
Counter Control using I/O ports	<ul style="list-style-type: none"> • Open Gate / Start Counter: Counter is enabled to count pulses • Close Gate / Stop Counter: Counter is disabled to count pulses • Preset Counter: Preset Value can be set in CIO • Reset Counter to zero (refer to section 4-2-3 <i>Details of Device Variables for CJ-series Unit (for input/output)</i>)
Output Control Mode	Automatic Output Control in: <ul style="list-style-type: none"> • Range Mode (Refer to section 3-5-1 <i>Range Mode</i>) • Comparison Mode (Refer to section 3-5-2 <i>Comparison Mode</i>)

Item	CJ1W-CTL41-E
Reset Signals	Every Counter can be reset to zero by (a combination of) the following sources: <ul style="list-style-type: none"> • Software Counter Reset Bit • Z-Input Refer to section 3-6 <i>Reset Signals</i> .
Extra Functions	Hysteresis: To prevent Outputs from being switched On and Off by very small fluctuations in the Counter Value around Range Limits, for every Counter an Hysteresis-value [1, 255] can be defined (the Unit must in Range Mode). Refer to section 3-7-1 <i>Hysteresis</i> .
Noise Filtering Counter Inputs	To suppress noise on the signal lines of the Counter Inputs (A, B) a fixed Noise Filter is provided: Counter Inputs A and B: 100 kHz
Initial Counter Value	The Initial Counter Value is transferred to the Unit when the Unit is Powered Up or Restarted. The Initial Counter Value is very useful to overcome problems in case of power failure. Refer to section 3-7-2 <i>Initial Counter Value</i> .
Error History Log Function	Stores up to 30 error log records (refer to section 5-2 <i>Error Codes</i>)

1-3-3 Input Specifications

Item	Counter Inputs A, B and Z
Input Voltage	Line Driver
Input Current (typical)	11 mA
Voltage levels	Connectable to RS-422 compatible Line Drivers.



Additional Information

The Counter Inputs (A, B, Z) are insulated from each other. All Counter Inputs are reverse polarity protected and insulated from the I/O bus.

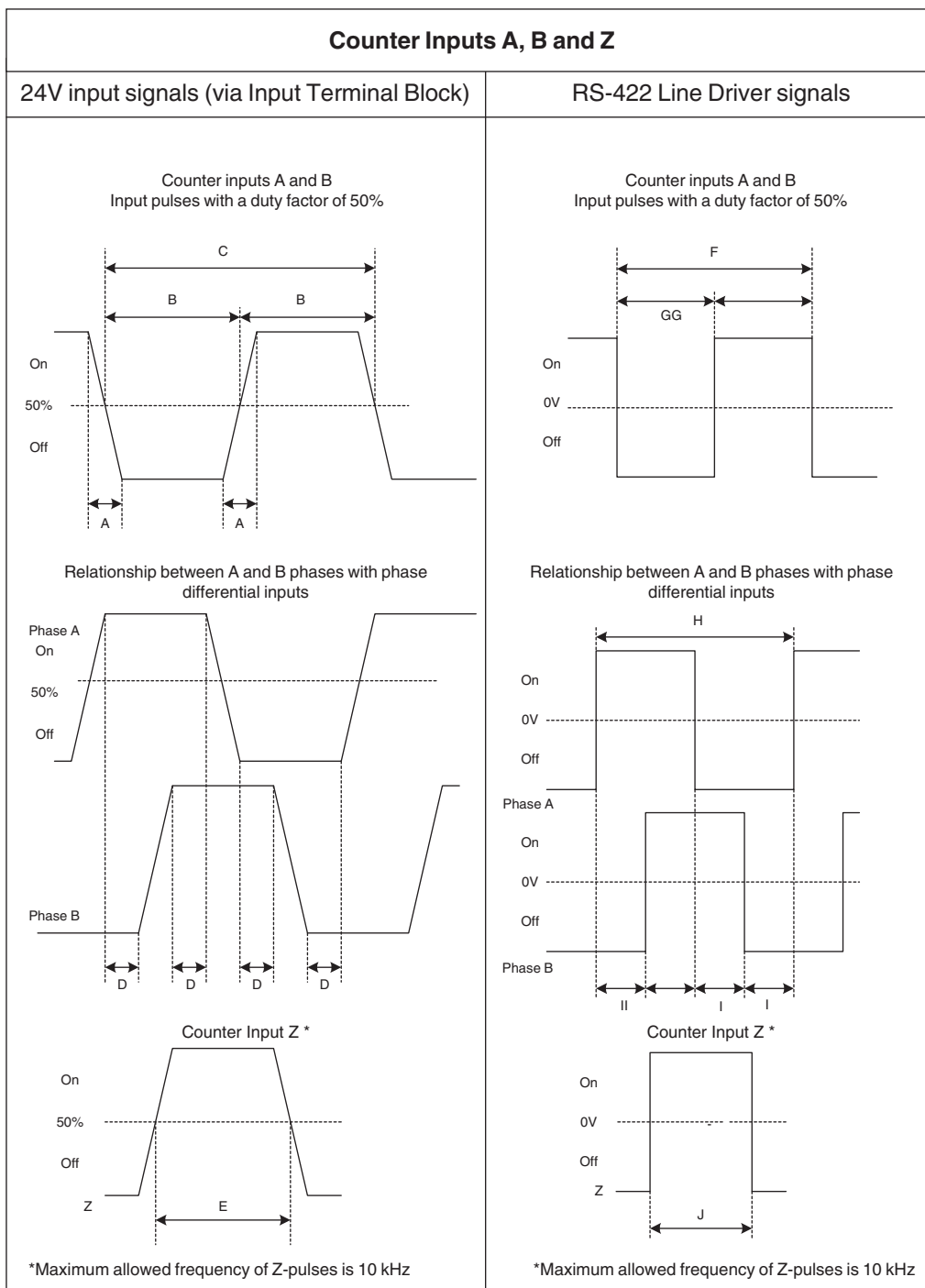

Filter Selection	Timing requirement [μs]									
	A	B	C	D	E	F	G	H	I	J
10 kHz	<3	>50	>100	>23	>10	>100	>50	>100	>23	>10
50 kHz	<3	>10	>20	>4.5	>10	>20	>10	>20	>4.5	>10
500 kHz	<3	>2	>4	>1	>10	>2	>1	>4	>1	>10



Additional Information

As a general guideline it can be stated that if you want the timing requirements for the Counter Inputs to satisfy the above mentioned specifications, you must pay attention to the type of output driver of the encoder being used, the length of the encoder cable and the frequency of the count pulses generated. For example, if you use an Open Collector encoder (e.g. E6B2-CWZ6C) at 24 V with 10 m cable, you can typically generate count pulses up to 20 kHz. Therefore, if you want to generate count pulses with higher frequencies, you should use a different type of encoder (e.g. E6B2-CWZ1X with Line Driver output or a fast push-pull 24 V encoder, e.g. E6C2-CWZ5GH) or reduce the length of the encoder cable.

1-4 Quick Start Up Reference Guide

● Operation and Configuration

Each individual Counter of the Counter Unit can be configured as Circular or Linear Counter (refer to section 1-5 *Operating Procedure Guidelines* for quick start up information).

The diagram below shows the functions the Unit has available to operate and configure the Unit (refer to Section 3, Operation and Configuration). The numbers in grey refer to the following table.

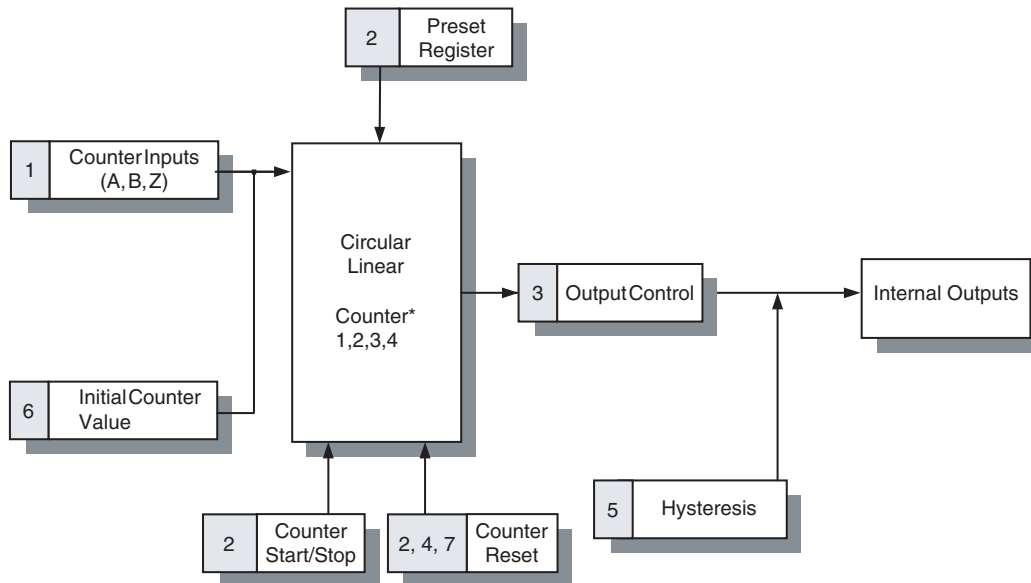

* Diagram is valid for Counter 1, 2, 3 and 4.

Ref	Item	Circular/Linear Counter	Reference Section
1	Input Signal types	Phase Differential (x1, x2, x4)	3-3-1
		Up & Down	3-3-2
		Pulse & Direction	3-3-3
2	Counter control	<ul style="list-style-type: none"> • Open Gate / Start Counter • Close Gate / Stop Counter • Preset Counter • Reset Counter 	3-4
3	Output control	• Range Mode	3-5-1
		• Comparison Mode	3-5-2
4	Counter reset	<ul style="list-style-type: none"> • Software Reset Bit • Z-signal 	3-6
5	Hysteresis	Yes	3-7-1
6	Initial counter values	Yes	3-7-2

1-4-1 Configuring the Counter Unit

● Configuring the Counter Type

Configuring each Counter starts with choosing the Counter Type, i.e. it must be configured for Circular or Linear Counter (refer to section 3-2-1 *Circular Counter* section 3-2-2 *Linear Counter* and section 1-5 *Operating Procedure Guidelines* for details).

● Configuring the Input Type

Next, the Input Type (Phase Differential, Up/Down, or Pulse & Direction) for every Counter has to be defined. During operation of the Counter, the Counter can be Started, Stopped, Reset, Captured or Preset by using the corresponding bits for the I/O port in the CPU Unit.

● Configuring the Output Mode

In order to link the Units Software Outputs to Counter events, the Output Control Mode (Range or Comparison Mode) must be selected. Furthermore, an additional Hysteresis mechanism is available to control the Outputs. Refer to section 3-5 *Output Control*.

● Specifying indirect addresses for Circular/Linear Counters and Allocating them to user-defined variables

CJ1W-CTL41-E 4-Channel Counter Units are set with the Special Unit Setup Editing of Sysmac Studio. When the contents of the Special Unit setup are transferred to the CPU unit, they are reflected in the device variables for CJ-series Unit (for setting). Furthermore, when the Controller is reset or the Unit is restarted, the contents of device variables for CJ-series Unit (for setting) are reflected in the Counter Unit.

Each counter can be supplied with range or comparison data. This data resides in either DM or EM memory area.

To make the setting, specify the indirect address for the Memory Address in Special Unit Setup Editing of Sysmac Studio. The indirect addresses point to the actual memory address where the range or comparison data is actually stored. After that, this area is allocated to user-defined variables.

For details on the data, refer to 3-5-1 *Range Mode* or 3-5-2 *Comparison Mode*.

For details on device variables for CJ-series Units, refer to 4-2 *Memory Allocation*.

Count operations are started with the gate open/close bit of the device variables for CJ-series Units or digital input, depending on the application.

1-5 Operating Procedure Guidelines

The operating procedures for the Counter Units are described here.

There is no restriction regarding the sequence of "Programs and software settings" and "Hardware setting and rack assembly." These tasks may be carried out concurrently or in the reverse order.

Use Sysmac Studio to create and set programs.

For details on operations of Sysmac Studio, refer to *Sysmac Studio NJ-One Version 1.0 Operation Manual (Cat. No. W504)*.

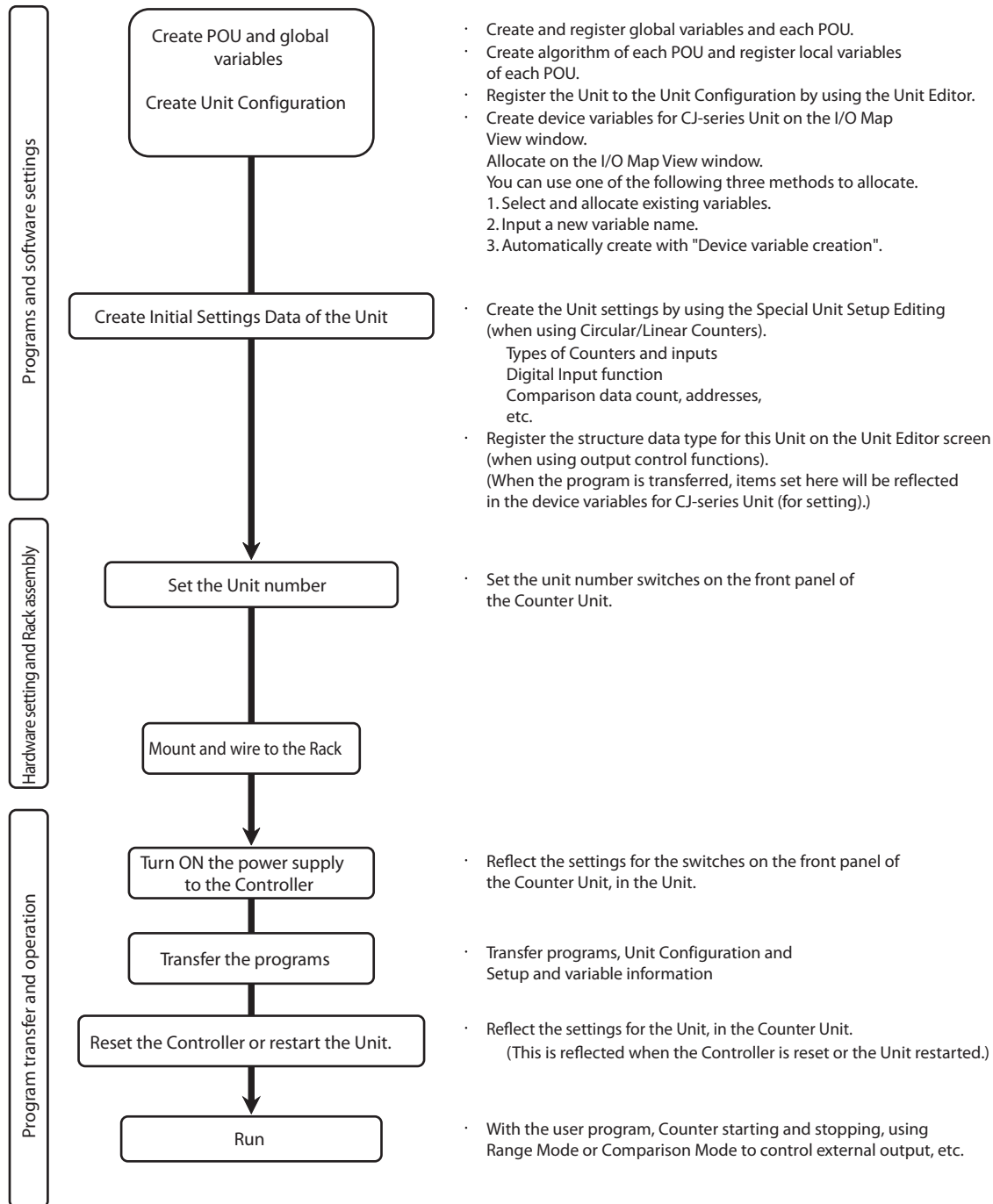

Details of Hardware Setting and Rack Assembly

● Set the Unit number

Set the Machine Number. Refer to 2-1-3 *Machine Number Switch* for further details.

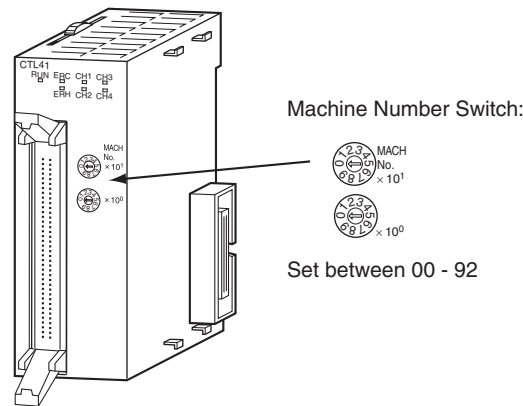

● Mounting and wiring to the Rack

Install and wire the Unit. Refer to 2-2 *Installation* and 2-3 *Wiring* for further details.

Create Initial Settings Data of the Unit

Create the initial settings data for the Unit on the Special Unit Setup Editing of Sysmac Studio. When setting in Simple Counters, there is no need to create this data.

Circular/Linear Counters:

The Counter Type (Linear or Circular) can be selected from Special Unit Setup Editing of Sysmac Studio.

Refer to Section 3 for detailed information about Unit settings.

When using the Counter Unit output control functions, register the structure data type for range or comparison data on the Unit Editor screen.

Refer to 3-2-1 *Circular Counter* and 3-2-2 *Linear Counter* for more details about both Counter Types.

Refer to 4-1-2 *Unit Restart* for more information about restarting the Unit.

1-6 Application Areas

The main application areas of the Counter Unit are where signals with high frequencies are counted and high-speed responses have to be triggered at predefined Counter Values. Application areas include:

- Packaging and Sorting plants
- Dosing or proportioning plants
- Process Industry

Typical applications in which the CJ1W-CTL41-E can be used:

- (CAM)-Positioning
- Position Monitoring
- Length Measurement
- Flow Control
- Energy Measurement

2

Components, Installation and Wiring

This section provides details of the components, switch settings and other information required to install and operate CJ1W-CTL41-E 4-Channel Counter Units.

2-1	Components and Switch Settings	2-2
2-1-1	Components	2-2
2-1-2	Indicators	2-2
2-1-3	Machine Number Switch	2-3
2-2	Installation	2-5
2-2-1	System Configuration Precautions	2-5
2-2-2	Installing Units	2-5
2-3	Wiring	2-7
2-3-1	Connector Pin Layout	2-7
2-3-2	Connector Wiring Methods	2-8
2-3-3	Important Wiring Considerations	2-9
2-3-4	Internal Circuitry	2-10
2-3-5	Counter Input Configuration	2-10

2-1 Components and Switch Settings

2-1-1 Components

● Front and Side View

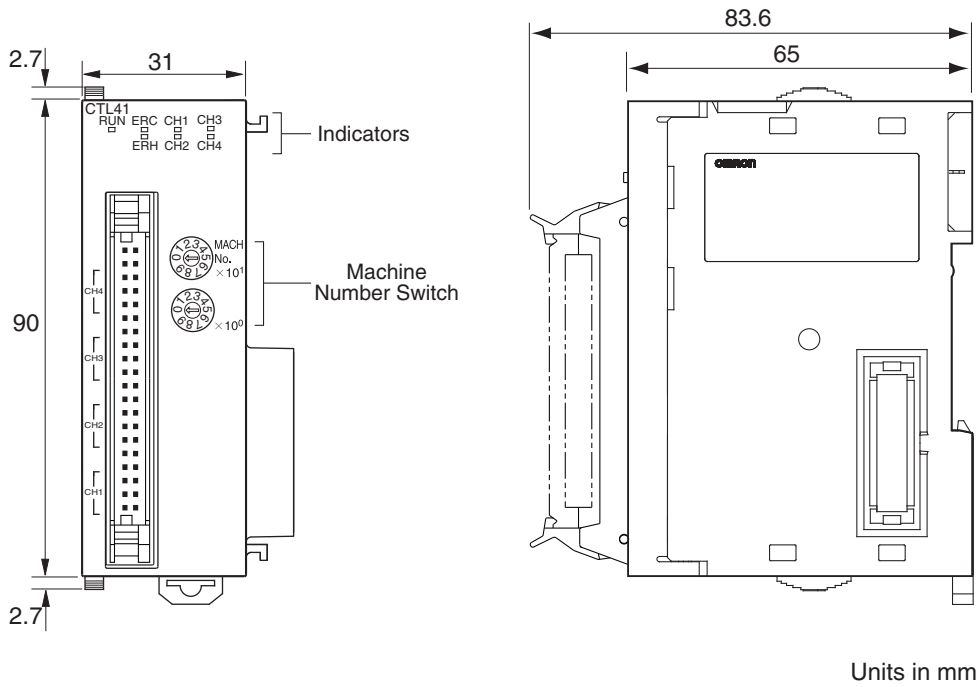

2-1-2 Indicators

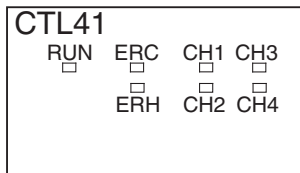

The indicators on the front display show the operating status of the Unit. The following table shows the meaning of the indicators.

Indicator	Color	State	Description
RUN	Green	ON	Unit is in operation (i.e. Unit has initialized normally after (re-) starting the Unit).
		OFF	Unit is not in operation (i.e. Unit was not able to initialise normally after (re-) starting the Unit or the power to the Unit is switched OFF).
ERC	Red	ON	Unit has operational failure due to a detected error. (For a list of all the errors that can cause an operational failure, see 5-2 Error Codes).
		OFF	Unit has no operational failure.

Indicator	Color	State	Description
ERH	Red	ON	CPU Unit has operational failure. (For a list of all the errors that can occur at the CPU Unit see 5-1 <i>Error Indicators</i>)
		OFF	CPU Unit has no operational failure.
CH1	Yellow	ON	Counter 1 is counting, i.e. the corresponding counting gate is enabled and at least one pulse has been detected.
		OFF	Counter 1 is not counting, i.e. the corresponding counting gate is closed or no pulses have been detected.
CH2	Yellow	ON	Counter 2 is counting, i.e. the corresponding counting gate is enabled and at least one pulse has been detected.
		OFF	Counter 2 is not counting, i.e. the corresponding counting gate is closed or no pulses have been detected.
CH3	Yellow	ON	Counter 3 is counting, i.e. the corresponding counting gate is enabled and at least one pulse has been detected.
		OFF	Counter 3 is not counting, i.e. the corresponding counting gate is closed or no pulses have been detected.
CH4	Yellow	ON	Counter 4 is counting, i.e. the corresponding counting gate is enabled and at least one pulse has been detected.
		OFF	Counter 4 is not counting, i.e. the corresponding counting gate is closed or no pulses have been detected.

2-1-3 Machine Number Switch

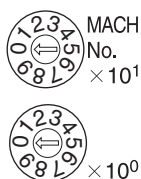

Use the unit number switches to set the unit number specific for each Special I/O Unit mounted in a CPU Rack or Expansion Rack.

Turn OFF the Controller before changing the unit number setting.

One 4-Channel Counter Unit occupies areas for four special I/O Units in a CPU Unit.



Precautions for Safe Use

Always turn OFF the controller power before setting the unit number.



Precautions for Correct Use

- When setting a rotary switch, use a flat-blade screwdriver and be careful not to damage the switch.
- Be sure not to leave the rotary switch midway between numbers.



Additional Information

- If two or more Special I/O Units are set to an identical Unit number or if one Special I/O Unit is set to areas of plural Unit numbers, the CPU Unit has a major fault level error "Duplicate Unit Number" and stops operation.
- After correcting the unit number setting, cycle the power to the Controller.

- One Counter Unit occupies allocation areas of four unit numbers. Be sure that no unit numbers are duplicated. To avoid duplication, when you set a High-speed Counter Unit to the unit number "n", set the next Special I/O Unit to the unit number "n + 4".
 - Besides the memory that is allocated to the Counter Unit in the Special I/O Unit DM Area, for every Counter additional memory can be allocated in DM/EM. This extra allocated amount of memory is used to make the Counter Specific Settings related to Range or Comparison Mode. Memory is allocated by specifying an Indirect Address for every Counter in the Special I/O Unit DM Area. For details about Indirect Addressing refer to section *4-2-2 Allocating Ranges and Comparison Data*.
-

2-2 Installation

2-2-1 System Configuration Precautions

The Counter Units are connectable with CPU Racks and Expansion Racks. A maximum of 10 Units can be mounted on a Rack, and a total of 24 Units on CPU Racks and Expansion Racks altogether.

2-2-2 Installing Units



Precautions for Correct Use

- Leave the protective label on top of the Unit as long as the Unit is not mounted and wired completely, in order to prevent wire clippings or other materials from getting inside the Unit. When the mounting and wiring has been completed, the label must be removed to allow air circulation and heat radiation.
- Be sure to turn OFF the power supply to the CPU before installing or removing Units or connecting or disconnecting connectors.

Use the following procedure to install CJ1W-CTL41-E Counter Units. Connect the Units before mounting them to DIN-rail.

- 1 Align the connectors and hooks accurately and press the Units together firmly when connecting them.

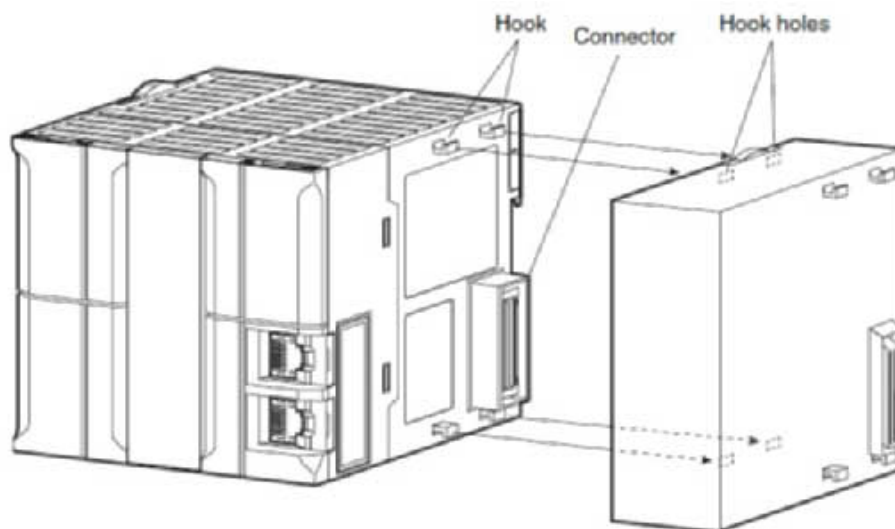

- 2 Slide the yellow sliders on the top and bottom of the Units until they click into place, firmly locking the Units together.

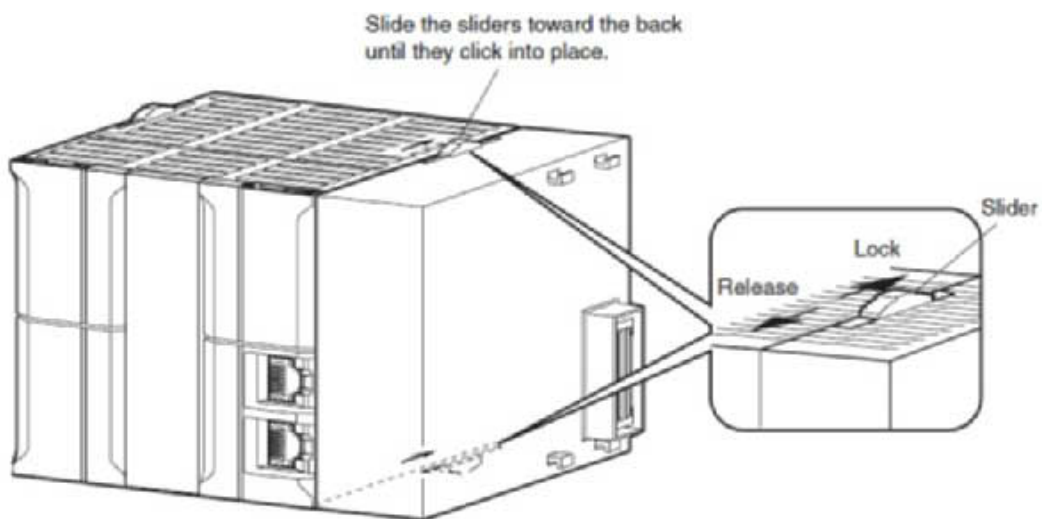

- 3** Attach an End Plate to the Unit on the right end of the Rack.



Precautions for Safe Use

The Units may not function properly if the sliders are not locked into place. Always connect the End Plate to the right most Unit. The NJ-series CPU will not function properly without the End Plate connected. The End Plate is provided with the CPU Unit.

2-3 Wiring

2-3-1 Connector Pin Layout

The 40-pin connector on the front of the Unit is divided into two rows, each row containing 20-pins as indicated in the figure below. The Counter Inputs of the Unit are logically grouped together and allocated to the pins of the connector. The following table lists the allocation of the external signals to the respective pins.

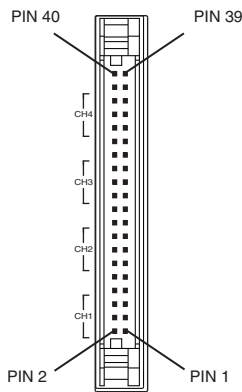

	Pin No.	Signal	Pin No.	Signal
	40	Not Connected	39	Not Connected
	38		37	
Channel 4	36	Z-	35	Z+
	34	B-	33	B+
	32	A-	31	A+
	30	Not Connected	29	Not Connected
28	27			
Channel 3	26	Z-	25	Z+
	24	B-	23	B+
	22	A-	21	A+
	20	Not Connected	19	Not Connected
18	17			
Channel 2	16	Z-	15	Z+
	14	B-	13	B+
	12	A-	11	A+
	10	Not Connected	9	Not Connected
8	7			
Channel 1	6	Z-	5	Z+
	4	B-	3	B+
	2	A-	1	A+

● Counter Inputs

To the Counter Inputs of the Counter Unit signals can be applied originating from one of the following driver types:

- RS-422 Line Driver, either directly connected to the connector on the front of the Unit or through a separate Input Terminal Block, e.g. the OMRON XW2G-40G7-E or XW2D-40G6.
- 24 VDC signals from NPN or PNP Drivers, only through the separate OMRON XW2G-40G7-E Input Terminal Block.

2-3-2 Connector Wiring Methods



Precautions for Correct Use

- Do not remove the label on top of the High-speed Counter Unit until the wiring has finished. Not doing could cause wire cuttings and other materials falling into the Unit or short circuit the internal circuitry, resulting in malfunctioning or burning. Be sure to remove the label after wiring the connectors to allow air circulation and heat radiation.
- Be sure that all the connectors are wired correctly and properly connected to the Counter Unit, to prevent the Unit from malfunctioning.

To wire the CJ1W-CTL41-E in order to connect the external signals three methods are available:

- 1** Directly connecting the wires and cables to an external connector. Recommended connectors are 40-pin MIL-C-83503 (or DIN 41651 or IEC 60603-1) compatible 40-pole connectors.
- 2** Indirectly connecting the wires and cables to the screw terminals of an XW2B-40Gx Terminal Block Unit, which is connected to the Unit with a standard XW2Z I/O cable. Both parts can be ordered separately.
- 3** Indirectly connecting the wires and cables to the screw-less terminals of an XW2G-40G7-E Terminal Block Unit, which is connected to the Unit with a standard XW2Z I/O cable. Both parts can be ordered separately.

The figures below show the XW2B-40Gx and XW2G-40G7-E Input Terminal Blocks.

● Terminal Block Unit

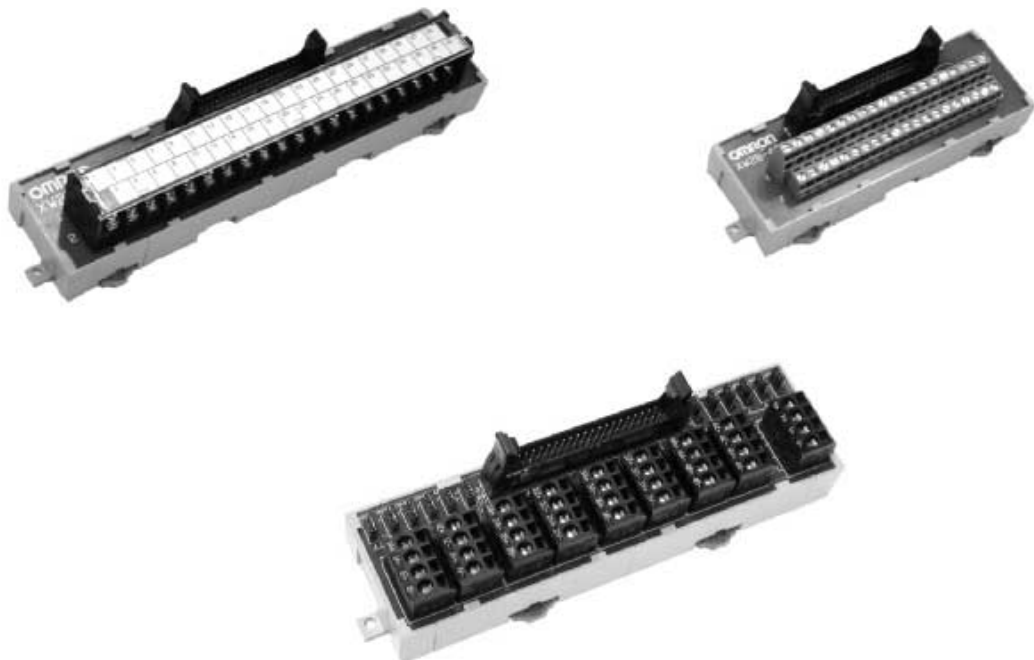

The following Terminal Block Units are recommended for using together with the CJ1W-CTL41-E Counter Unit:

Item	Description	Input type supported
XW2B-40G4	40 screw terminals (M2.4)	Line driver only
XW2B-40G5	40 screw terminals (M3.5)	Line driver only
XW2D-40G6	40 screw terminals, compact	Line driver only
XW2G-40G7-E	36 screwless terminals	Line driver / 24 VDC

These Terminal Block Units can be mounted to a DIN-rail or to a flat surface using screws. The connector on front of the Unit must be connected to a Terminal Block Unit through a standard (40 wire) cable. For this purpose you can use the standard available cables with product-number XW2Z-xxxK. The length of the cable is indicated by 'xxx' in centimetres. The following cables are available:

- XW2Z-050K (0.5 m)
- XW2Z-100K (1 m)
- XW2Z-150K (1.5 m)
- XW2Z-200K (2 m)
- XW2Z-300K (3 m)
- XW2Z-500K (5 m)

The next figure shows how to use the Terminal Block Unit in a typical configuration together with the CJ1W-CTL41-E Counter:

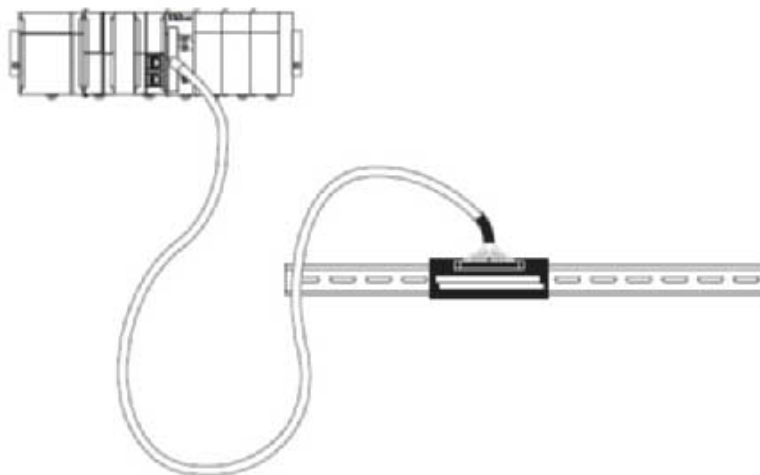

Refer to section A-2 *Using Terminal Block Units with Screw-terminals* for information on the numbering of the screw-terminals. You need this information in case you want to connect the external signals via Terminal Block Units to the Counter Unit.

2-3-3 Important Wiring Considerations

Use the following guidelines when planning the system wiring of the Unit:

- Disconnect the power to the CPU before wiring the Unit.
- Make sure the system is properly grounded.
- Use shielded, twisted pair cables and ground the shield when wiring the Counter Inputs (A, B, Z). When grounding the shield at the side of the Unit, use the same reference as the ground terminal of the CPU Power Supply.
- Make the wiring for the Counter Inputs A, B and Z as short as possible and do not route the wires parallel to lines that produce excessive noise, such as high-voltage power lines.

- Use a separate stabilized Power Supply for the Counter Unit and another Power Supply for other Units.

2-3-4 Internal Circuitry

● Counter Input Circuitry

The figure below shows the internal input circuitry for all three digital input signals for each of the four Counter channels.

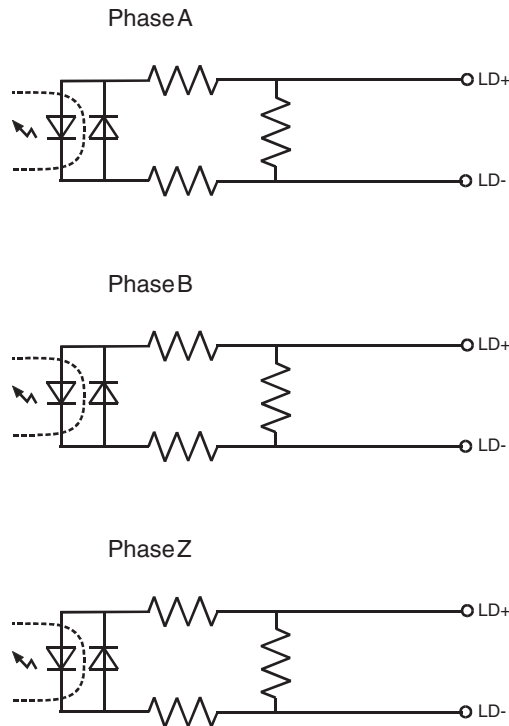

2-3-5 Counter Input Configuration

The following example illustrates how to wire the Counter Inputs in a typical configuration according to the output-driver of the encoder or proximity switch being used. In the example Counter channel 1 is used. The configuration shown here, related to a specific output driver, can also be referred to in case other pulse generating equipment with similar output-drivers is being used.

● Line Driver (RS422)

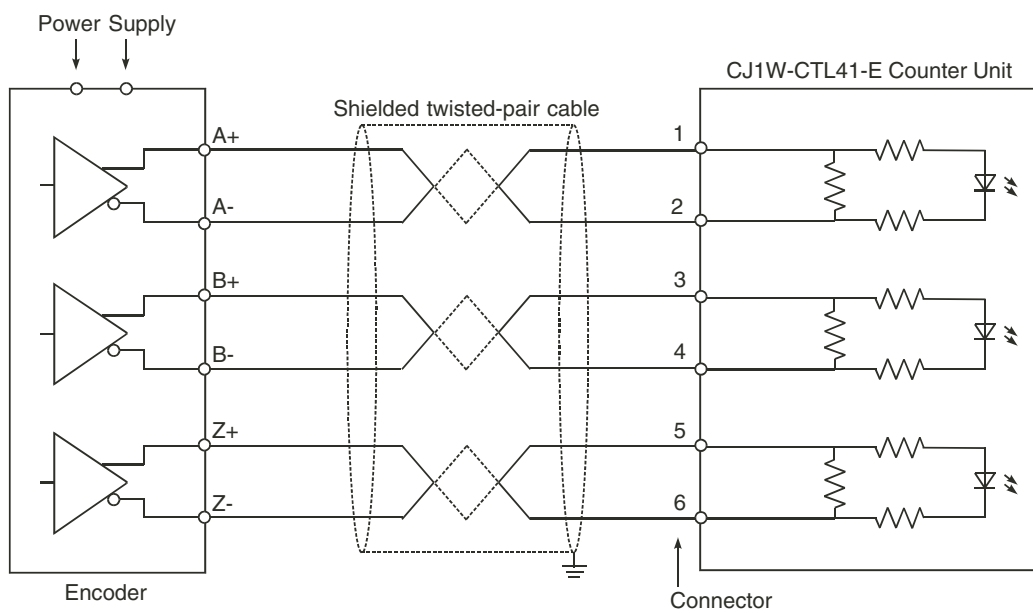
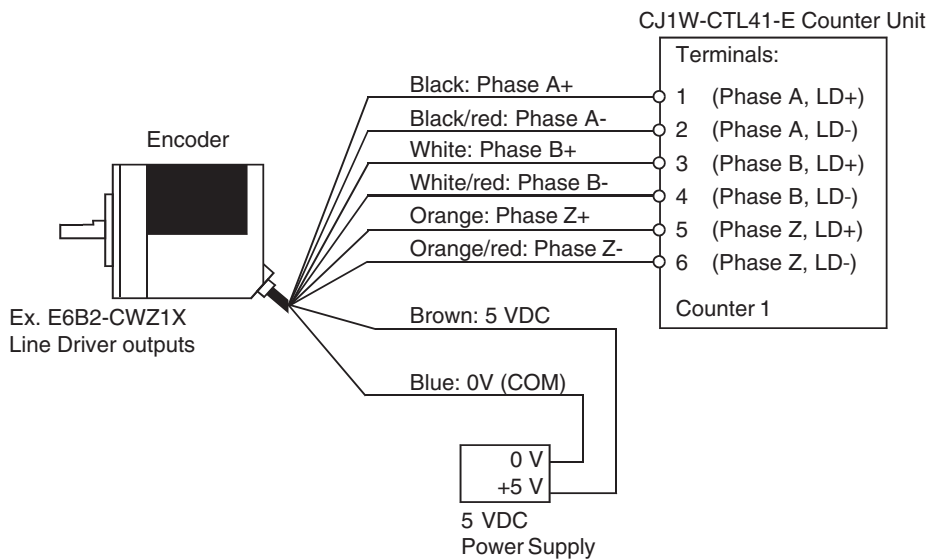

3

Operation and Configuration

This section describes how to configure the CJ1W-CTL41-E 4-Channel Counter Unit and how to operate the Unit according to the specific requirements of your application.

3-1 Overview	3-2
3-1-1 Summary	3-2
3-1-2 List of Functions/Allocation Areas by Purpose	3-2
3-2 Counter Types	3-4
3-2-1 Circular Counter	3-4
3-2-2 Linear Counter	3-5
3-3 Input Signal Types	3-8
3-3-1 Phase Differential	3-8
3-3-2 Up & Down Pulse	3-9
3-3-3 Pulse & Direction	3-9
3-4 Controlling a Counter	3-11
3-5 Output Control	3-13
3-5-1 Range Mode	3-14
3-5-2 Comparison Mode	3-20
3-6 Reset Signals	3-27
3-7 Extra Functions	3-29
3-7-1 Hysteresis	3-29
3-7-2 Initial Counter Value	3-30

3-1 Overview

3-1-1 Summary

You can make the Unit settings after you complete registration of the CJ1W-CTL41-E 4-Channel Counter Unit to the Unit Configuration and registration of device variables for CJ-series Unit.

Unit settings are made with Special Unit Setup Editing of Sysmac Studio. Alternatively, set device variables for CJ-series Unit (for setting) (refer to section 4-1 *Overview*) in the user program.

This section describes how to set the CJ1W-CTL4-E 4-Channel Counter Unit to meet the concrete needs of the user application. (Refer to section 1-4 *Quick Start Up Reference Guide* for an overview of the configuration items for every Counter).

Also throughout this section, the device variables for CJ-series Unit (for input/output) that are relevant to operate the Unit from the CPU Unit user program are mentioned. For details on device variables for CJ-series Unit (for input/output), refer to section 4-2-3 *Details of Device Variables for CJ-series Unit (for input/output)*.

For details of device variables for CJ-series Unit (for setting), refer to 4-2-4 *Details of Device Variables for CJ-series Unit (for setting)*.

3-1-2 List of Functions/Allocation Areas by Purpose

The following tables show explanations of functions used (reference) as well as names of device variables for CJ-series Unit (for input/output) and names of device variables for CJ-series Unit (for setting) for the purpose of use with the Counter Units.

Determining How the Counter Will Be Used

Purpose	Explanation of functions used (reference)	Name of device variable for CJ-series Unit (for input/output)	Name of device variable for CJ-series unit (for setting)
To select a pulse input method	3-3 <i>Input Signal Types</i> <ul style="list-style-type: none"> • Phase differential • Up & down pulse • Pulse & direction 	---	<ul style="list-style-type: none"> • Counter Types • Signal Types • Z-reset Mode/Overflow/Underflow error-code generation • Upper Count Limit Circular/Linear • Lower Count Limit Linear
To select a Counter Reset technique	3-6 <i>Reset Signals</i>	<ul style="list-style-type: none"> • Reset • Reset Enable • Reset Activated • Z-signal Activated 	<ul style="list-style-type: none"> • Z-reset Mode/Overflow/Underflow error-code generation

Counter Operations

Purpose	Explanation of functions used (reference)	Name of device variable for CJ-series Unit (for input/output)	Name of device variable for CJ-series Unit (for setting)
When used for Linear Counter operation	3-2-2 <i>Linear Counter</i> 3-5-1 <i>Range Mode</i> 4-2-2 <i>Allocating Ranges and Comparison Data</i> 4-2-5 <i>Memory Allocation for Ranges</i>	<ul style="list-style-type: none"> • Ranges/Comparison Values active 	<ul style="list-style-type: none"> • Output Control Mode/AND/OR Counter Output Patterns • Counter Type • Upper Count Limit Circular/Linear • Lower Count Limit Linear • Range/Comparison Enable Data • Output Set Pattern • Output Reset Pattern • Number of Ranges/Comparison Values • Memory Area • Memory Address
When used for Circular Counter operation	3-2-1 <i>Circular Counter</i> 3-5-1 <i>Range Mode</i> 4-2-2 <i>Allocating Ranges and Comparison Data</i> 4-2-5 <i>Memory Allocation for Ranges</i>	<ul style="list-style-type: none"> • Ranges/Comparison Values active 	<ul style="list-style-type: none"> • Output Control Mode/AND/OR Counter Output Patterns • Counter Type • Upper Count Limit Circular/Linear • Range/Comparison Enable Data • Output Set Pattern • Output Reset Pattern • Number of Ranges/Comparison Values • Memory Area • Memory Address
When used for Preset Counter operation	3-5-2 <i>Comparison Mode</i> 4-2-2 <i>Allocating Ranges and Comparison Data</i> 4-2-6 <i>Memory Allocation for Comparison Data</i>	<ul style="list-style-type: none"> • Preset • Preset Value • Preset Activated 	<ul style="list-style-type: none"> • Output Control Mode/AND/OR Counter Output Patterns • Range/Comparison Enable Data • Output Set Pattern • Output Reset Pattern • Number of Ranges/Comparison Values • Memory Area • Memory Address

3-2 Counter Types

Every individual counter of the Counter Unit can be set independently to one of the following counter Types (for an overview of the differences between Circular and Linear Counters refer to section 1-4 *Quick Start Up Reference Guide*):

- Circular Counter (refer to Section 3-2-1 *Circular Counter*)
- Linear Counter (refer to Section 3-2-2 *Linear Counter*)

In the description hereafter, each variable name has a prefix "*". This indicates the device name when this Unit is registered in the Unit Configuration. For details, refer to section 4-1-3 *Access from User Program*.

Name of device variable for CJ-series Unit	Type	Name	Function
*_Ch1_CtTypCfg	UINT	Counter Type	Counter Type selection 0: Circular counter type 1: Linear counter type
*_Ch2_CtTypCfg			
*_Ch3_CtTypCfg			
*_Ch4_CtTypCfg			

● Counter Value

For all Counter Types the 32-bit Counter Value is stored in the device variables for CJ-series Unit (for input): The data range depends on the type of counter.

Name of device variable for CJ-series Unit	Type	Name	Function
*_Ch1_LinCtVal	DINT	Counter Value	Counter Value for Linear Counter -2,147,483,648 to +2,147,438,647 Pulses
*_Ch2_LinCtVal			
*_Ch3_LinCtVal			
*_Ch4_LinCtVal			
*_Ch1_RingCtVal	UDINT	Counter Value	Counter Value for Circular Counter 0 to +4,294,967,295 Pulses
*_Ch2_RingCtVal			
*_Ch3_RingCtVal			
*_Ch4_RingCtVal			

3-2-1 Circular Counter

● Configuring Circular Counters

Circular counters are set with the following device variables for CJ-series Units (for setting).

Name of device variable for CJ-series Unit	Type	Name	Function
*_Ch1_CtTypCfg	UINT	Counter Type	Counter Type Selection 0: Circular counter type 1: Linear counter type
*_Ch2_CtTypCfg			
*_Ch3_CtTypCfg			
*_Ch4_CtTypCfg			

A Circular Counter has 32-bits (the full counting range) available to count up- or downwards over the positive counting range between 0 and the Upper Count Limit.

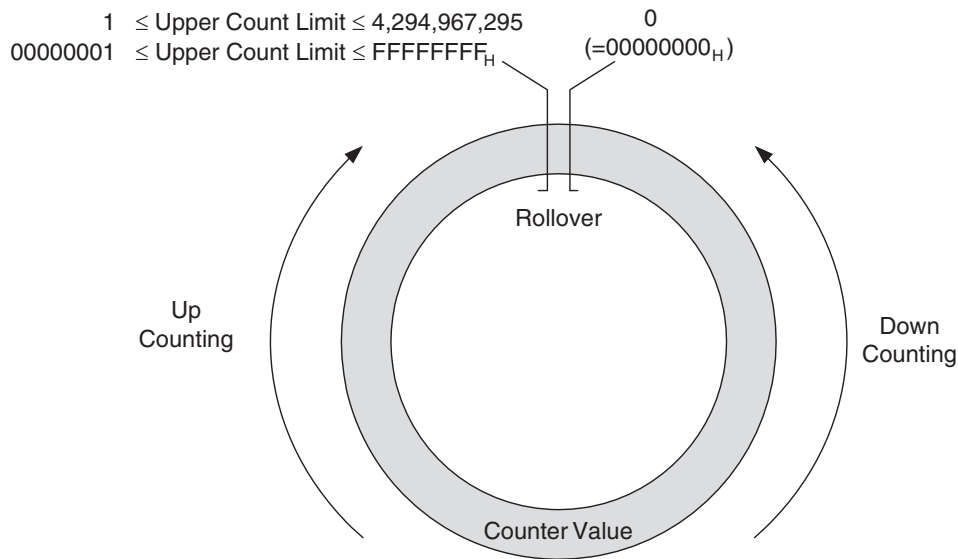

● Configuring Upper Count Limit

The Upper Count Limit can be configured between 1 and 4,294,967,295. By default the Upper Count Limit is equal to the maximum possible count limit of 4,294,967,295. When 0 is set, this becomes 4,294,967,295.

For Circular Counters the Counter automatically rolls over to 0 if the Counter Value exceeds the Upper Count Value and continues counting. If the Counter Value goes below 0 the Counter rolls over to the Upper Count Value and continues counting.

Name of device variable for CJ-series Unit	Type	Name	Function
*_Ch1UpCtLmtCfg	UINT	Circular/Linear Upper Count Limit	Set the upper count limit 0 to 4,294,967,295 Pulses
*_Ch2UpCtLmtCfg			
*_Ch3UpCtLmtCfg			
*_Ch4UpCtLmtCfg			

3-2-2 Linear Counter

● Configuring Linear Counters

Name of device variable for CJ-series Unit	Type	Name	Function
*_Ch1_CtTypCfg	UINT	Counter Type	Counter Type Selection 0: Circular counter type 1: Linear counter type
*_Ch2_CtTypCfg			
*_Ch3_CtTypCfg			
*_Ch4_CtTypCfg			

A Linear Counter has the full counting range (=32 bits) available to count upwards or downwards over the positive and negative counting range between the Minimum Count Limit and the Maximum Count Limit. By default the Minimum and Maximum Count Limits are set to the maximum counting limits (i.e. -2,147,483,648 and +2,147,483,647 respectively).

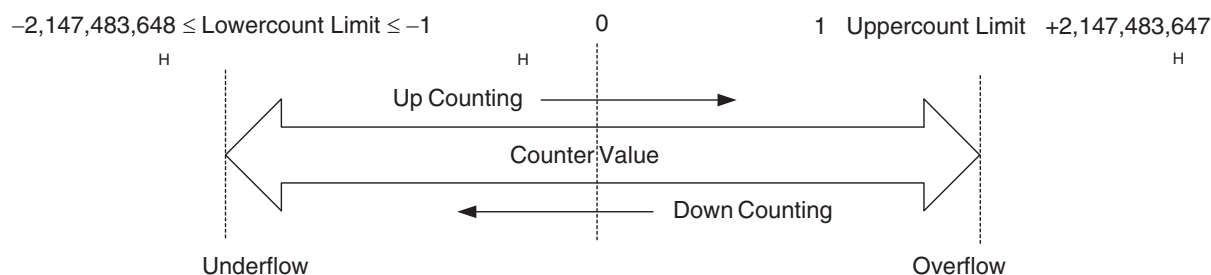

If the Counter Value goes above the Upper Count Limit or below the Lower Count Limit an Overflow and Underflow flag will be set respectively in the device variable for CJ-series Units.

On occurrence of an Overflow or Underflow, every Counter can be configured to set a corresponding Error-Code Generation flag (Bits 04 to 07). You can use Overflow/Underflow Error-Code Generation to store Overflow and Underflow errors in the EEPROM inside the Unit (refer to Section 5-2-2 *Overflow/Underflow errors*).

● Configuring Upper and Lower Count Limits

The Upper Count Limit must be positive and the Lower Count Limit must be negative (zero is not allowed as Count Limit). To set the Upper and Lower Count Limits refer to the following.

Name of device variable for CJ-series Unit	Type	Name	Function
*_Ch1_UpCtLmtCfg	UDINT	Upper Count Limit, Circular/Linear	Circular/Linear Upper Count Limit 0 to 4,294,967,295 Pulses • When 0 is set, this becomes 2,147,483,647.
*_Ch2_UpCtLmtCfg			
*_Ch3_UpCtLmtCfg			
*_Ch4_UpCtLmtCfg			
*_Ch1_LowCtLmtCfg	DINT	Lower Count Limit, Linear	Linear Lower Count Limit -2,147,483,648 to 0 Pulses • When 0 is set, this becomes -2,147,483,647.
*_Ch2_LowCtLmtCfg			
*_Ch3_LowCtLmtCfg			
*_Ch4_LowCtLmtCfg			

● Configuring Error-Code Generation

To configure Overflow/Underflow Error Code Generation for a Linear Counter refer to the following.

Name of device variable for CJ-series Unit	Type	Name	Function
*_Ch1_ZOvfUdfCfg	WORD	Z-reset, Overflow/Underflow Error-Code Generation	Bits 00 to 03: Z phase reset 16#0: No function 16#1: Reset Bits 04 to 07: Overflow/underflow error setting 16#0: Do not generate error codes. 16#1: Generate error codes. Bits 8 to 15: 00
*_Ch2_ZOvfUdfCfg			
*_Ch3_ZOvfUdfCfg			
*_Ch4_ZOvfUdfCfg			

● Reporting Overflow and Underflow

An Overflow or Underflow of a Linear Counter is reported device variables for CJ-series Units (for input).

Name of device variable for CJ-series Unit	Type	Name	Function
*_Ch1_CtOvf	BOOL	Counter Overflow	Counter Overflow
*_Ch2_CtOvf			0: Upper Count Limit of Linear Counter is not reached
*_Ch3_CtOvf			1: Upper Count of Limit of Linear Counter is reached.
*_Ch4_CtOvf			
*_Ch1_CtUdf		Counter Underflow	Counter Underflow
*_Ch2_CtUdf			0: Lower Count Limit of Linear Counter is not reached
*_Ch3_CtUdf			1: Lower Count Limit of Linear Counter is reached
*_Ch4_CtUdf			

3-3 Input Signal Types

The type of input you require for your application is selected by means of the device variable for CJ-series Units (for setting). For every Counter the Signal Type can be selected individually.

Name of device variable for CJ-series Unit	Type	Name	Function
*_Ch1_SigTypCfg	UINT	Signal Type	Signal Type Selection
*_Ch2_SigTypCfg			0: Phase Differential (x1)
*_Ch3_SigTypCfg			1: Phase Differential (x2)
*_Ch4_SigTypCfg			2: Phase Differential (x4) 4: Up & Down Pulse 8: Pulse & Direction

3-3-1 Phase Differential

Phase Differential Signals are connected to the inputs A, B and Z of every Counter. The count direction is determined by the phase angle between input A and input B. If signal A leads to B, the counter increments. If signal B leads to A, the counter decrements.

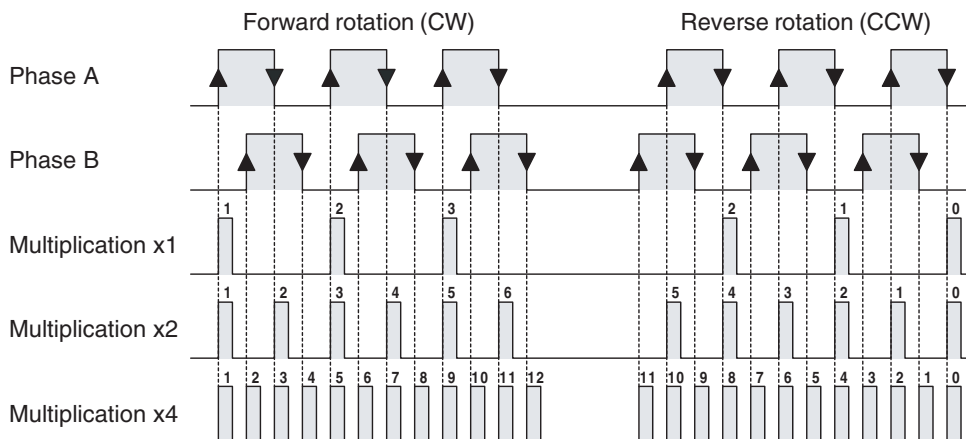
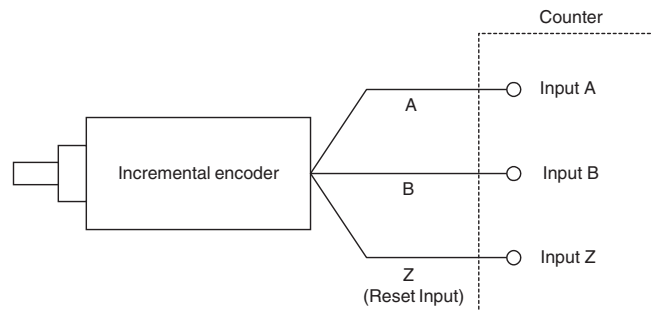

- **Multiplication x1**

By default the Counter is configured for Multiplication by 1. If the counter is up-counting (signal A leads to signal B) pulses are taken into account by the Counter on the rising edges of signal A. If the Counter is down-counting pulses are taken into account on the falling edges of input A.

● **Multiplication x2**

To increase the resolution of the incremental encoder the Counter can be configured for Multiplication by 2. If the Counter is up-counting (signal A leads to signal B) pulses are taken into account by the Counter on the rising- and falling edges of signal A. If the Counter is down-counting pulses are also taken into account on the rising- and falling edges of signal A.

● **Multiplication x4**

To further increase the resolution of the incremental encoder Multiplication *4 should be selected. If the Counter is up-counting (signal A leads to signal B) pulses are taken into account by the Counter on the rising- and falling edges of signal A and signal B. If the counter is down-counting pulses are also taken into account on the rising- and falling edges of signal A and B.



Additional Information

For Counter Reset options (Z-input included) refer to Section 3-6 *Reset Signals*.

3-3-2 Up & Down Pulse

With this Signal Type the Counter increments on the rising edge of pulses applied to input A and decrements on the rising edge of pulses applied to input B.

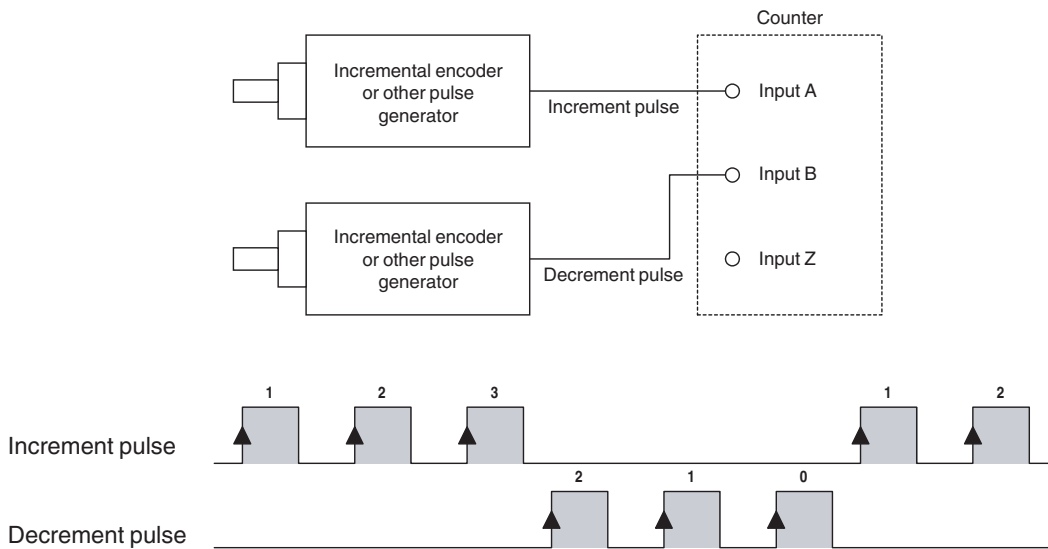

Additional Information

For Counter Reset options refer to section 3-6 *Reset Signals*.

3-3-3 Pulse & Direction

In this configuration, count pulses are applied to input A. The direction of counting is controlled by the level of the signal applied to input B. If input B is high, the Counter increments on the rising edges of input A. If input B is low, the Counter decrements on the rising edges of input A.

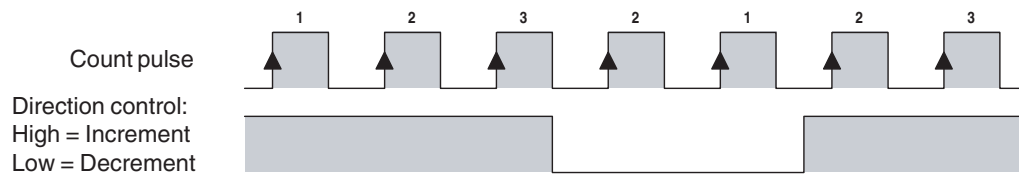
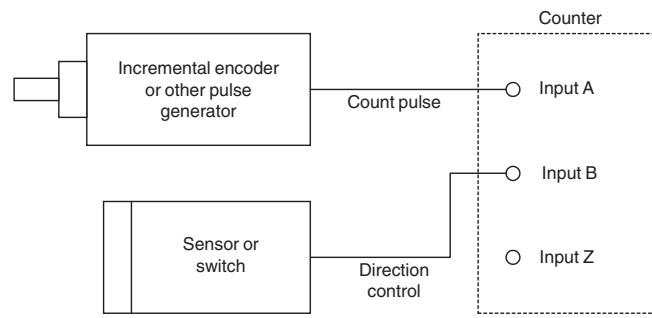

Additional Information

For Counter Reset options refer to section 3-6 *Reset Signals*.

3-4 Controlling a Counter

Each Counter Input contains a gate through which the counting function can be enabled or disabled. When disabled, the gate will block incoming counter signals.

The Gate of a Counter can be enabled and disabled with the following device variables for CJ-series Units (for setting).

Name of device variable for CJ-series Unit	Type	Name	Function
*_Ch1_Enbl	BOOL	Open Gate	Open Gate
*_Ch2_Enbl			0 to 1: Open Gate (A rising edge of the Open Gate Bit opens the Gate regardless of the state of the Close Gate Bit)
*_Ch3_Enbl			
*_Ch4_Enbl			
*_Ch1_Dsbl		Close Gate	Close Gate
*_Ch2_Dsbl			0 to 1: Close Gate (A rising edge of the Close Gate Bit closes the Gate regardless of the state of the Open Gate Bit)
*_Ch3_Dsbl			
*_Ch4_Dsbl			



Additional Information

- At simultaneous rising edge of both bits, the state of the Gate is unchanged.
- Initially, at power up or restart of the Unit, for both counter types (i.e. Circular and Linear Counters) the Gate is closed and counting is disabled. In order to enable counting you must open the Gate first.

● Preset Function

The Unit is equipped with a Preset Register for every Counter that contains the Preset Value. To change the Preset Value you can change the device variables for CJ-series Unit (for output) of the corresponding Counter. The Counter Value is overwritten with the Preset Value at a rising edge of the Preset Counter Bit of the corresponding Counter.

Name of device variable for CJ-series Unit	Type	Name	Function
*_Ch1_Prst	BOOL	Preset	Load Preset Value
*_Ch2_Prst			0 to 1: Load Preset Value
*_Ch3_Prst			
*_Ch4_Prst			
*_Ch1_PrstLinCtVal	DINT	Preset Value	Preset Value for Linear Counter
*_Ch2_PrstLinCtVal			-2,147,483,648 to 2,147,483,647 Pulses
*_Ch3_PrstLinCtVal			
*_Ch4_PrstLinCtVal			
*_Ch1_PrstRingCtVal	UDINT	Preset Value	Preset Value for Ring Counter
*_Ch2_PrstRingCtVal			0 to 4,294,967,295 Pulses
*_Ch3_PrstRingCtVal			
*_Ch4_PrstRingCtVal			

● Reset Function

To reset a Counter, through a signal pulse on the corresponding Z-input, the Z-input Reset Enable bit must be set to 1. A Counter can also be reset by using the device variable for CJ-series Units. Setting this bit to '1' causes a forced reset of the corresponding Counter. Refer to section 3-6 *Reset Signals* for detailed information about resetting Counters.

Name of device variable for CJ-series Unit	Type	Name	Function
*_Ch1_Rst	BOOL	Reset	Forced Counter Value Reset 0 to 1: Reset Counter Value to 0
*_Ch2_Rst			
*_Ch3_Rst			
*_Ch4_Rst			

● Z-Input Status

For each counter the Z-input status is reflected the device variable for CJ-series Units. The bit is TRUE for exactly one task period of the CPU after the Z-input has been activated.

Name of device variable for CJ-series Unit	Type	Name	Function
*_Ch1_ZSig	BOOL	Z-signal Activated	Z-Signal Activated 0: Z-signal not active 1: Z-signal active
*_Ch2_ZSig			
*_Ch3_ZSig			
*_Ch4_ZSig			

● Counting Direction

For every Counter the (up or down) counting direction is indicated and can be used in the user program.

Name of device variable for CJ-series Unit	Type	Name	Function
*_Ch1_CntDir	BOOL	Counting Direction	Counting Direction 0: Down 1: Up
*_Ch2_CntDir			
*_Ch3_CntDir			
*_Ch4_CntDir			



Additional Information

The Reset, Preset and Z-signal bits are TRUE for exactly one CPU-cycle after the occurrence of a (short) pulse which was detected since the previous I/O Refresh.

3-5 Output Control

● Output Control Mode

The 32 Soft (internal) outputs of the Counter Unit can be controlled automatically in two ways:

- Range Mode: In Range Mode you can define up to a maximum of 4 Ranges per Counter. The Outputs are controlled according to the Counter Value being within Range Limits. For a detailed description about Range Mode refer to section 3-5-1 Range Mode.
- Comparison Mode: In Comparison Mode you can define up to a maximum of 8 Comparison Values per Counter. The Outputs are controlled according to the direction in which the Counter Value crosses the Comparison Value. For a detailed description about Comparison Mode refer to section 3-5-2 Comparison Mode.

If the Unit is configured for Range Mode all Counters will operate in Range Mode. If the Unit is configured for Comparison Mode all Counters will operate in Comparison Mode.

Name of device variable for CJ-series Unit	Type	Name	Function
*_OutCtlMdCfg	WORD	Output Control Mode, AND/OR Counter Output Patterns	Output Control Mode selection and Counter output pattern selection Bits 0 to 7 sets the Output Control Mode <ul style="list-style-type: none"> • 16#00: Range Mode • 16#01: Comparison Mode Bits 8 to 15 sets the Counter output pattern for AND or OR selection <ul style="list-style-type: none"> • 16#00: OR • 16#01: AND

● Unit Output Pattern

Both in Range and Comparison Mode the 32 Outputs of the Unit are represented by the Unit Output Pattern. The Unit uses the Unit Output Pattern internally to control the Outputs. The Unit Output Pattern consists of 32 Soft (internal) Outputs.

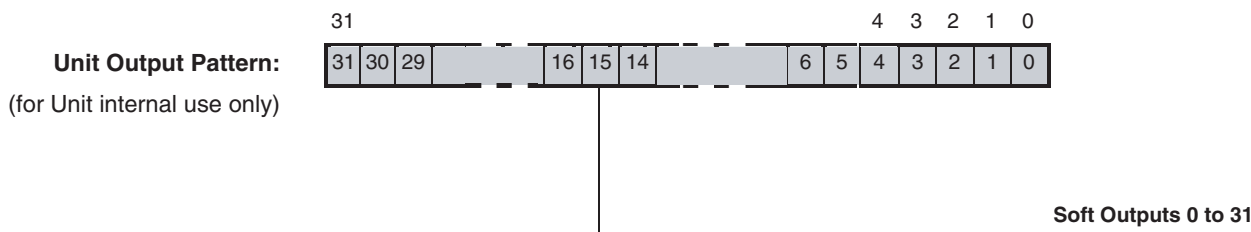

● Output Status

The status of the digital outputs is reflected in the device variables for CJ-series Unit (for input). There are two types of variables: one type has one variable for each bit status and the other has one variable that summarizes all 32 bit statuses. The former types of output statuses can be used to control outputs of external Basic Output Units from user programs.

Name of device variable for CJ-series Unit	Type	Name	Function
*_OutStaDat	DWORD	Output Status	The current statuses of the internal outputs (total of 32) are all displayed. 0: FALSE 1: TRUE Bit 00: Internal output 00 Bit 01: Internal output 01 ... Bit 31: Internal output 31
*_OutSta0 to *_OutSta31	BOOL	Output 0 to 31 Status	Individual internal output status 0: FALSE 1: TRUE

3-5-1 Range Mode

If the Unit is configured to control the Outputs in Range Mode, this Mode can be applied to Circular Counters or Linear Counters (refer to section 3-2-1 *Circular Counter* and section 3-2-2 *Linear Counter* for more information).

● Example Range Mode with Linear Counter

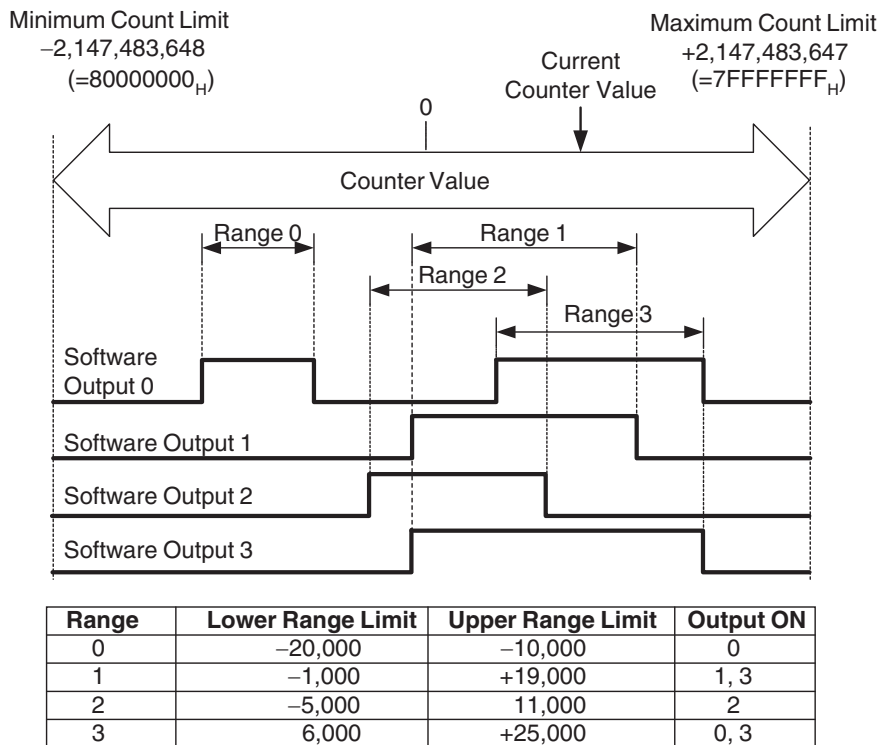

In this example four Ranges are specified. The configuration data of the Counter shows that:

- Output 0 must be TRUE for Counter Values within Range 0.
- Output 1 and 3 must be TRUE for Counter Values within Range 1.
- Output 2 must be TRUE for Counter Values within Range 2.
- Both the Software Outputs 0 and 3 must be TRUE for Counter Values within Range 3.

In the above example the Counter Value is within Range 1 and 3 and consequently the Outputs 0, 1 and 3 are changed to TRUE.

● **Example Range Mode with Circular Counter**

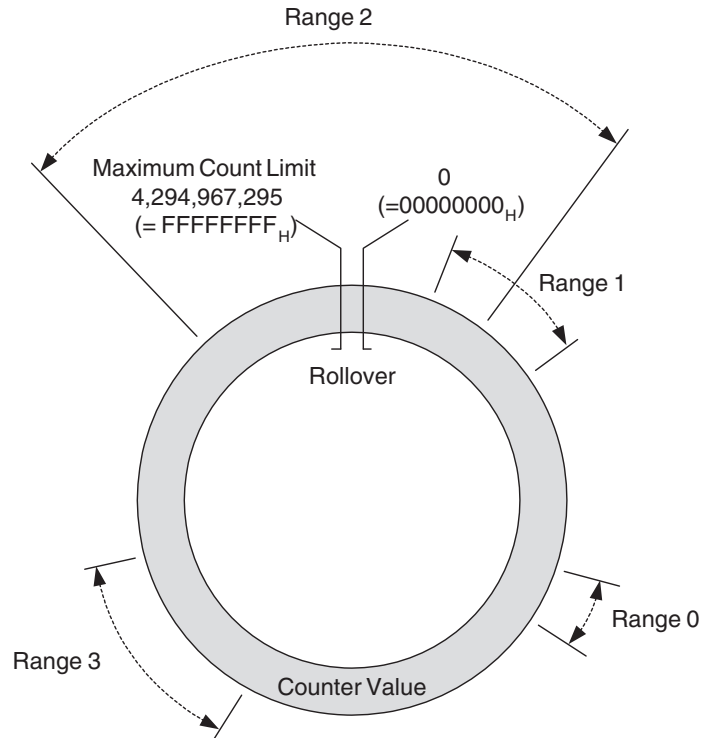

Range	Lower Range Limit	Upper Range Limit	Output ON
0	60,000	80,500	0
1	500	45,000	1, 3
2	37,000,000	6,000	2
3	99,000	150,000	0, 3

This example shows the Range Mode applied to a Circular Counter.

The following figure gives an overview on configuring Counters in Range Mode.

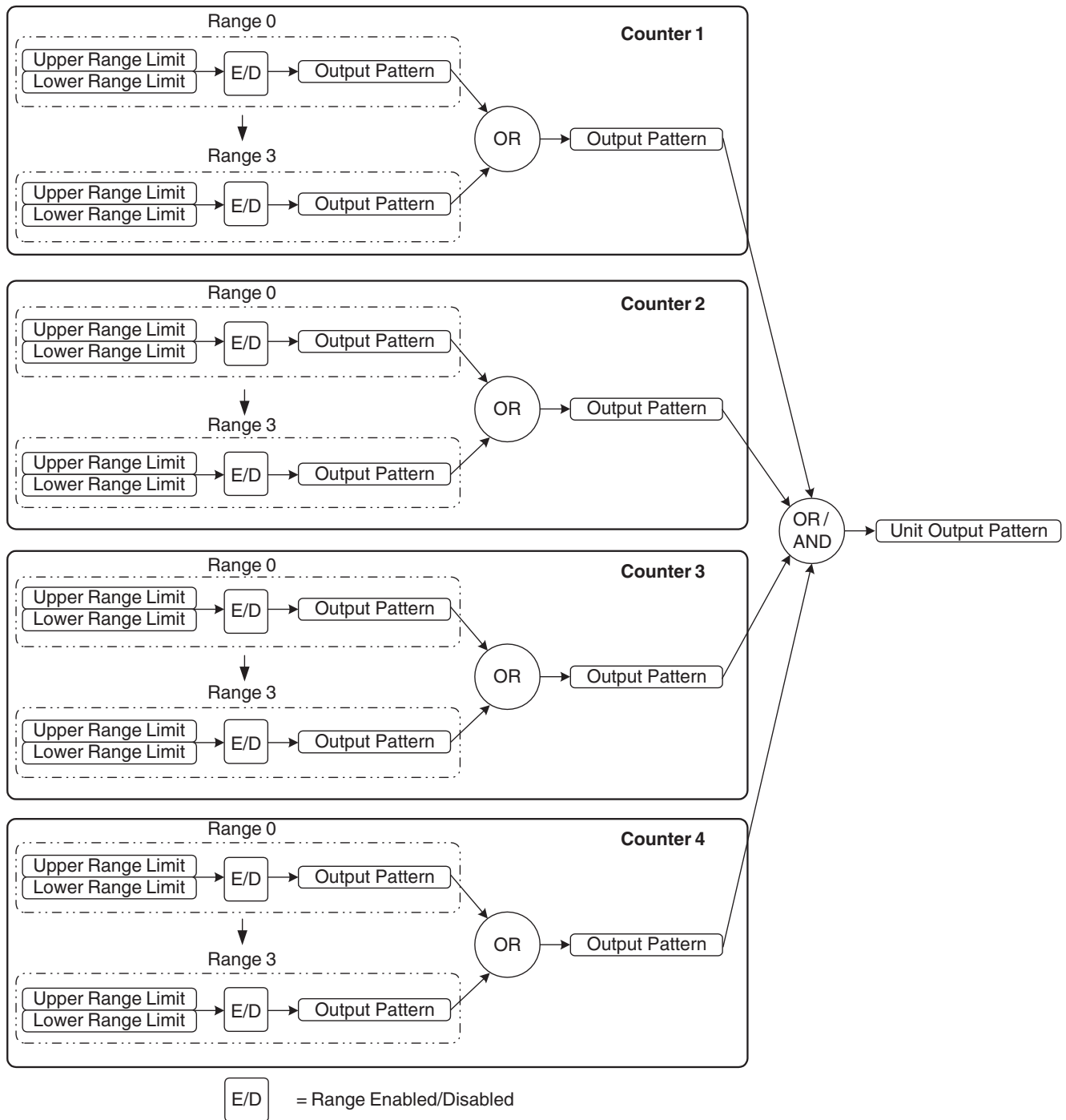

Configuration and Operation in Range Mode

● Specifying Range Data

In Range Mode every Counter can be assigned up to a maximum of 4 Ranges. The Data of every Range is contained by 3 double words:

- Lower Range Limit, specifying the Lower Limit of the Range
- Upper Range Limit, specifying the Upper Limit of the Range
- Output Pattern, specifying which Outputs have to be activated when that Range is active

The Counter Type (Circular or Linear) determines the range in which the Upper and Lower Limits can be set. For Circular Counters this range is 0 to 4,294,967,295 and for Linear Counters this range is -2,147,483,648 to 2,147,483,647. For Linear Counters the Upper Range Limit must be greater than the Lower Range Limit. The Unit will generate an error if the Upper Range Limit \leq Lower Range Limit (refer to section 5-2 *Error Codes* for more details). For Circular Counters, the Upper Range Limit can be set lower than the Lower Range Limit.

To configure a Counter in Range Mode for every Range that you want to use the Range-Data must be set. Each data-item is specified using the structure data type shown next. In order to use structure data types for range data, register the structure data type for Counter Units beforehand with the Unit Editor screen of Sysmac Studio. For the exact memory location to set the Range-Data refer to section Section 4-2-1 *Memory Mapping*.

Counter setting	Structure data type name	Member	Name	Data type	Function
Linear counter	_sCJCTL41_Ex_RngLin	LowLmt	Lower Limit	DINT	Range data lower limit setting
		UpLmt	Upper Limit		Range data upper limit setting
		OutPat	Output Pattern	DWORD	Output pattern setting for when range conditions are met: Bit 00 to 31: Internal output 0 to 31
Circular counter	_sCJCTL41_Ex_RngRing	LowLmt	Lower Limit	DINT	Range data lower limit setting
		UpLmt	Upper Limit		Range data upper limit setting
		OutPat	Output Pattern	DWORD	Output pattern setting for when range conditions are met: Bit 00 to 31: Internal output 0 to 31

In the Output Pattern of the Range every single Output can be configured to turn ON when that Range is active. To configure an Output to turn ON you must set the corresponding bit to 1. If multiple Ranges of a Counter are active at the same time, the Output Patterns of those Ranges are logically OR'ed to become the Output Pattern of that Counter.



Additional Information

- If Range Mode is used with Ring Counter Mode, a maximum ring value of 3 or more should be set up. Note that a value of 1 or 2 will not generate an error message.
- In Range Mode it is possible to apply Hysteresis to Ranges in order to prevent outputs from toggling due to unwanted oscillating of an encoder. Refer to section 3-7-1 *Hysteresis* for detailed information.
- Precautions When Setting Range Data
 - The comparison operation stops for 1.5 ms from when the Counter Value falls within the Upper Range Limit or Lower Range Limit for the Range Data. However, the comparison does not stop for other Counters.
 - Set the Range Data considering the time when the comparison is stopped.
 - For example, for the Range table shown in the following diagram, approximately 4.8 counts occur during 1.5 ms when a 3.2 kHz pulse is input. This means that comparison does not occur for Counter Values 101, 102, 103, and 104. During this period, the Output set under the Output Pattern does not turn ON even if the Counter Value is within the Range Data range.
 - Comparison starts again after this 1.5 ms has elapsed.

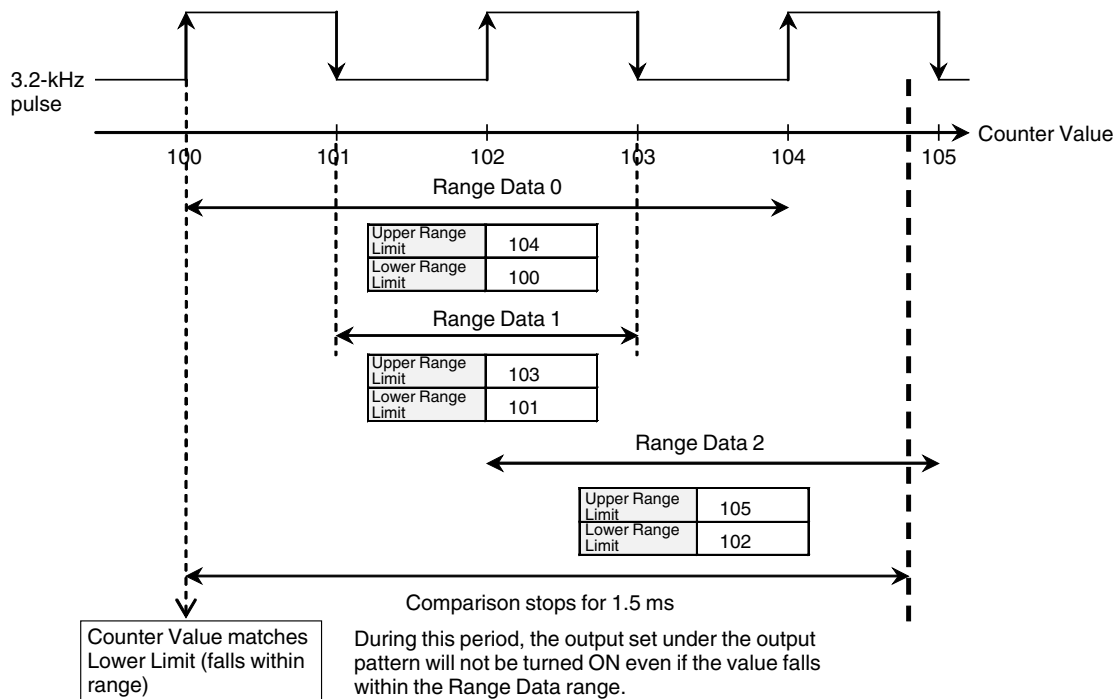

● Reflecting Active/Not Active Ranges

A Range becomes active if: Lower Range Limit ≤ Counter Value ≤ Upper Range Limit. Whether or not a Range is active will be reflected in the following device variables for CJ-series Units (for input) for each counter.

Name of device variable for CJ-series Unit	Type	Name	Function
*_Ch1_RngCmpDatSta	WORD	Range/Comparison Values active	The current status of the range conditions are shown. Bits 00 to 03 correspond to range conditions 0 to 3. Each bit shows 1 when the conditions are met and 0 when they are not.
*_Ch2_RngCmpDatSta			
*_Ch3_RngCmpDatSta			
*_Ch4_RngCmpDatSta			
*_Ch1_RngCmpSta0 to *_Ch1_RngCmpSta3	BOOL	Range condition 0 to 3 met or not	Range 0 to 3 status 0: Range conditions not met 1: Range conditions met
*_Ch2_RngCmpSta0 to *_Ch2_RngCmpSta3			
*_Ch3_RngCmpSta0 to *_Ch3_RngCmpSta3			
*_Ch3_RngCmpSta0 to *_Ch3_RngCmpSta3			



Additional Information

- The above device variables function as Comparison value active status when comparison mode is used. See section 3-5-2 Comparison Mode.
- Lower Range Limit = Upper Range Limit can be set under the Range conditions.

● **Enabling and Disabling of Ranges**

Each range condition can be enabled/disabled separately. When a pair of range conditions is set to disabled (the default setting), that output pattern is ignored when the unit output pattern is calculated. When a pair of range conditions is set to enabled, if conditions are established, that output pattern is applied to the output pattern of the corresponding counter. The range condition enabled/disabled status for a counter is set in the device variable for CJ-series Unit (for setting) shown below.

Name of device variable for CJ-series Unit	Type	Name	Function
*_Ch1_RngCmpEnbICfg	DWORD	Range/Comparison Enable Data	Sets whether the range/comparison data is enabled or disabled. Bits 00-03: 0: Disable 1: Enable
*_Ch2_RngCmpEnbICfg			
*_Ch3_RngCmpEnbICfg			
*_Ch4_RngCmpEnbICfg			



Additional Information

- The above device variables function as Comparison value active status when in comparison mode. See section 3-5-2 *Comparison Mode*.
- Bits set for non-existing ranges or counter values will be ignored.

● **Logically AND/OR Counter Output Patterns**

In Range Mode, output patterns of two Counters are logically summed (logical OR) and the result is regarded as the output pattern for the Unit. This is the default setting. If necessary, the operation can be changed from logical OR to logical AND. When it is set to logical AND, output patterns of two Counters are logically multiplied and the result is regarded as the output pattern for the Unit.

If multiple Counters are used together to control an application, you have the option to logically AND or OR the Counter Output Patterns to become the Unit Output Pattern. In this way it is possible to turn Outputs ON or OFF depending on Ranges being active of multiple Counters. For instance, it is possible to turn an Output ON when both a Range of Counter 1 and a Range of Counter 2 are active. To configure the Unit to AND the Counter Output Patterns refer the following.

Name of device variable for CJ-series Unit	Type	Name	Function
*_OutCtlMdCfg	WORD	Output Control Mode, AND/OR Counter Output Patterns	Bits 0 to 7: Output Control Mode Sets the Output Control Mode. 16#00: Range Mode 16#01: Comparison Mode Bits 8 to 15: Counter output pattern AND/OR selection For Range Mode, selects whether the Counter output pattern is logically OR or AND. 16#00: OR 16#01: AND



Additional Information

The Counter Output Patterns of Counters which are configured to use no (i.e. zero) Ranges, are ignored in the AND-calculation of the Unit Output Pattern. Like this, Counters that you do not want to use, do not influence the AND-calculation of the Unit Output Pattern. If both the Counters are configured to use no Ranges, the output patterns for both outputs will be all OFF.

3-5-2 Comparison Mode

If the Unit is configured to control the Outputs in Comparison Mode, this Mode can be applied to Circular Counters or Linear Counters (refer to section 3-2-1 *Circular Counter* and section 3-2-2 *Linear Counter* for more information).

● **Example Comparison Mode with Linear Counter**

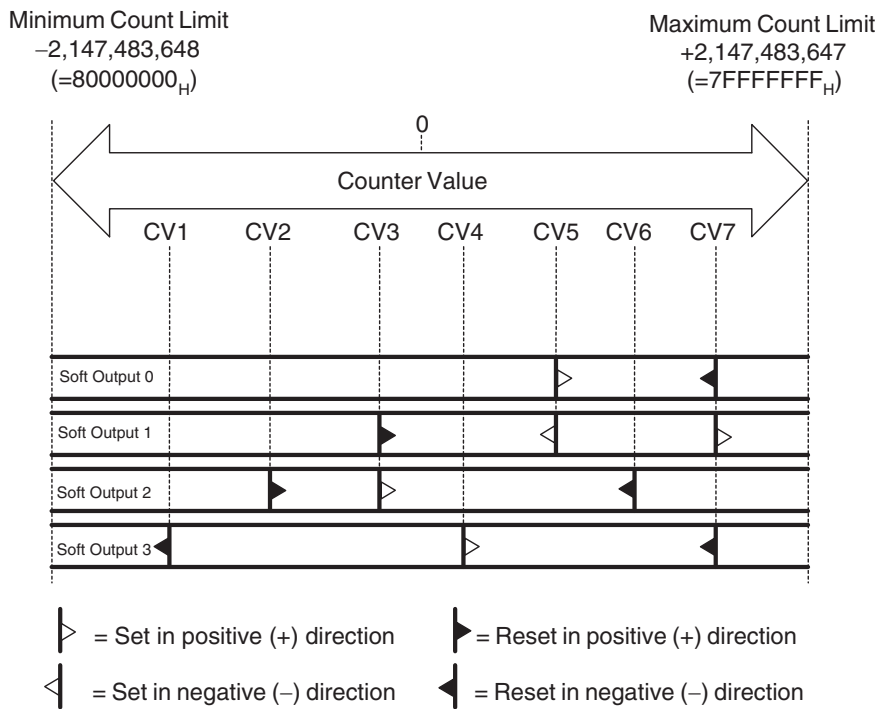

CV	Value	CV Crossing	Soft0	Soft1	Soft2	Soft3
1	-87,000	+CV crossing				
		-CV crossing				R
2	-56,000	+CV crossing			R	
		-CV crossing				
3	-15,000	+CV crossing		R	S	
		-CV crossing				
4	+18,000	+CV crossing				S
		-CV crossing				
5	+46,000	+CV crossing	S			
		-CV crossing		S		
6	+70,000	+CV crossing				
		-CV crossing			R	
7	+108,000	+CV crossing				
		-CV crossing	R	S		R

In this example 7 Comparison Values are specified. On reaching a Comparison Value an Output can be Set or Reset depending on the crossing direction. If the CV is crossed in the positive counting direction (+CV crossing) or negative counting direction (-CV crossing), one or multiple Outputs can be Set (S) or Reset (R).

For example Output 0 is Set on crossing CV5 in the positive counting direction and Reset on crossing CV7 in the negative counting direction. The crossing of CV3 in the positive counting direction results in the Setting of Output 2 and the Resetting of Output 1.

● Example Comparison Mode with Circular Counter

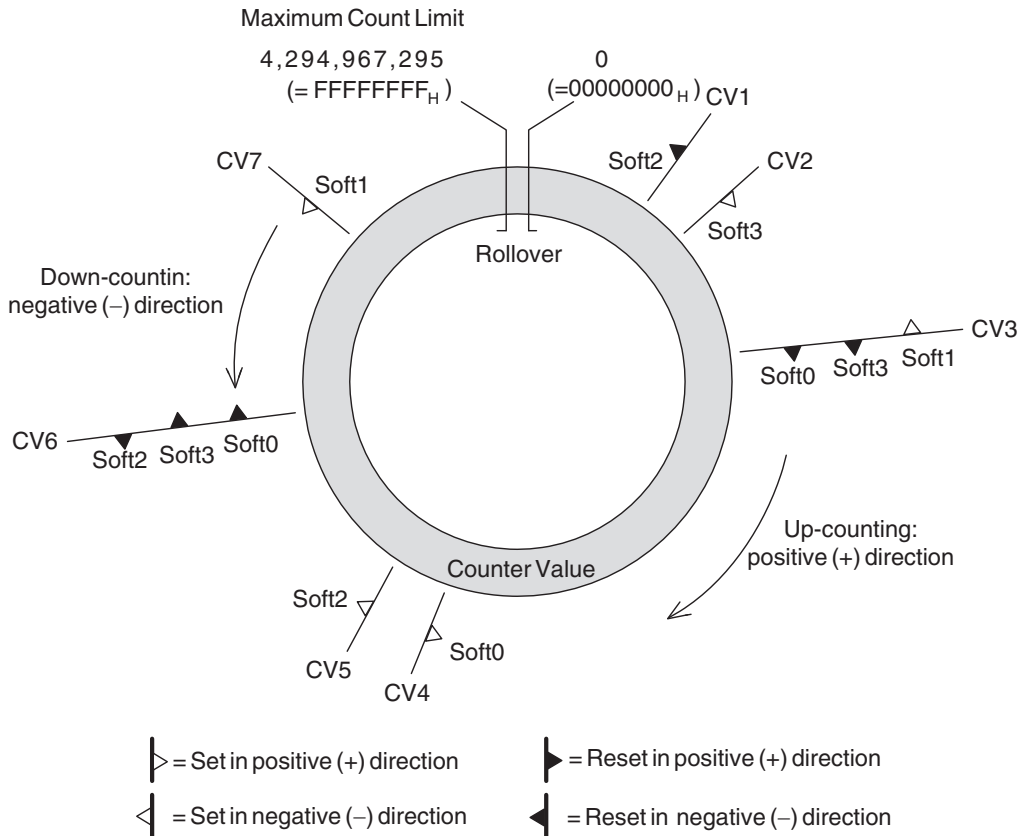

CV	Value	CV Crossing	Soft0	Soft1	Soft2	Soft3
1	750	+CV crossing				
		-CV crossing			R	
2	1,800	+CV crossing				S
		-CV crossing				
3	59,000	+CV crossing	R			R
		-CV crossing		S		
4	85,000	+CV crossing				
		-CV crossing	S			
5	90,000	+CV crossing			S	
		-CV crossing				
6	108,000	+CV crossing	R			R
		-CV crossing			R	
7	125,000	+CV crossing				
		-CV crossing		S		

This example shows the Comparison Mode applied to a Circular Counter.

The following figure gives an overview on configuring Counters in Comparison Mode.

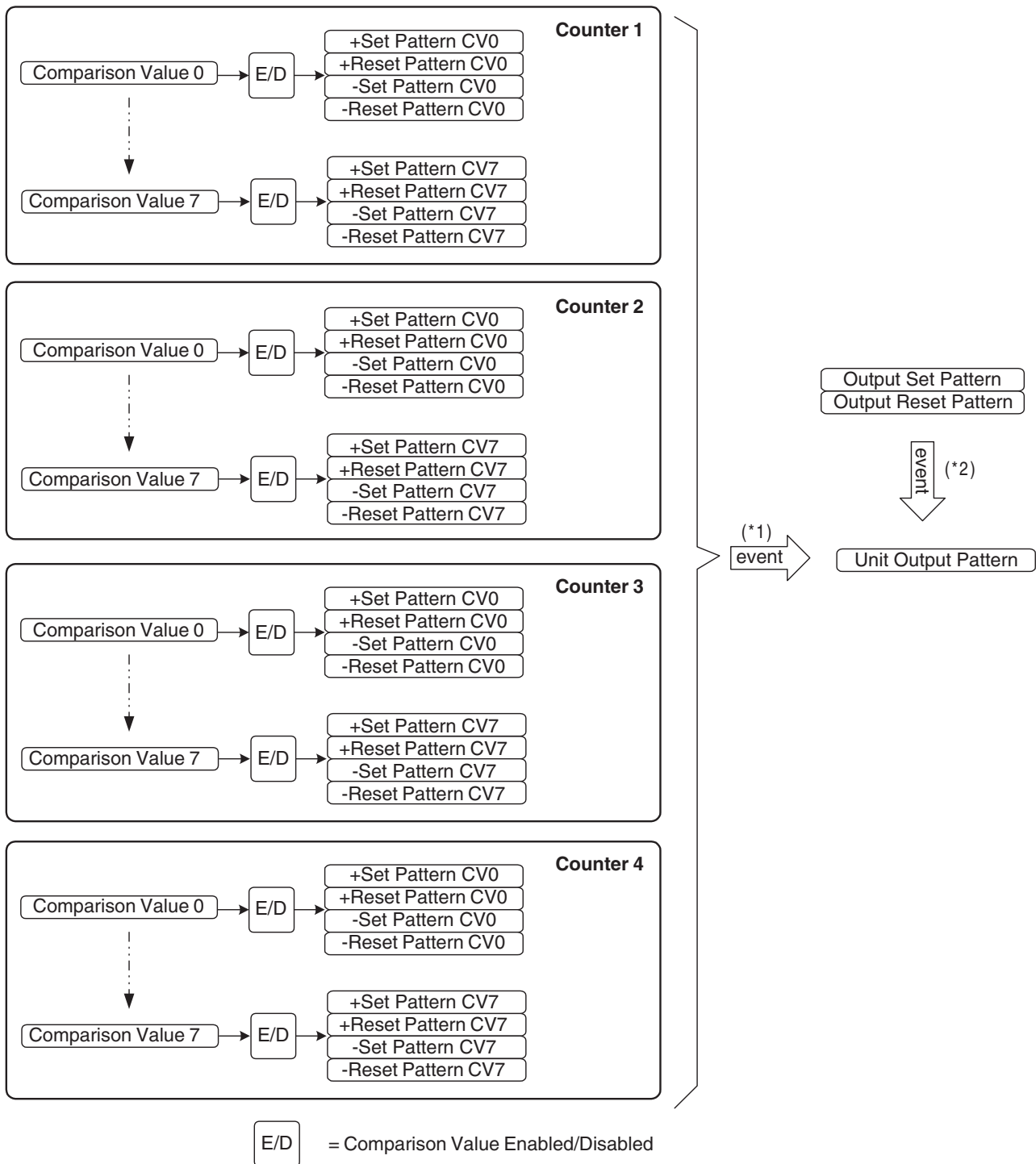

*1. Event = Crossing of Comparison Value

*2. Event = Preset or Reset Action

Configuration and Operation in Comparison Mode

● Specifying Comparison-Data

In Comparison Mode every Counter can be assigned up to a maximum of 8 Comparison Values. The Data of every Comparison Value (CV-Data) is contained by 5 double words:

- Comparison Value (can be set between $-2,147,483,648$ and $2,147,483,647$ for a Linear Counter and between 0 and $4,294,967,295$ for a Circular Counter)
- Output Set Pattern for the positive counting direction (+Set Pattern CV'n'), specifying which Outputs must be Set on reaching that CV in the positive counting direction (0 = No Change, 1 = Set Output)
- Output Reset Pattern for the positive counting direction (+Reset Pattern CV'n'), specifying which Outputs must be Reset on reaching that CV in the positive counting direction (0 = No Change, 1 = Reset Output)
- Output Set Pattern for the negative counting direction (-Set Pattern CV'n'), specifying which Outputs must be Set on reaching that CV in the negative counting direction (0 = No Change, 1 = Set Output)
- Output Reset Pattern for the negative counting direction (-Reset Pattern CV'n'), specifying which Outputs must be Reset on reaching that CV in the negative counting direction (0 = No Change, 1 = Reset Output)

To configure a Counter in Comparison Mode for every Comparison Value that you want to use the comparison data must be set. Each data-item is specified using the structure data type shown next. In order to use structure data types for comparison data, register the structure data type for Counter Units beforehand on the Unit Editor screen of Sysmac Studio. For the exact memory location of the CV-Data, refer to section 4-2-1 *Memory Mapping*.

Counter setting	Structure data type name	Member	Name	Data type	Function
Linear Counter	_sCJCTL41_Ex_CmpLin	CmpVal	Comparison Value	DINT	The target value set for comparison
		AddSetPat	+Set Pattern	DWORD	Output pattern setting when comparison conditions are met. Bit 00 to 31: Internal output 0 to 31
		AddRstPat	+Reset Pattern	DWORD	
		SubSetPat	-Set Pattern	DWORD	
		SubRstPat	-Reset Pattern	DWORD	
Circular Counter	_sCJCTL41_Ex_CmpRing	CmpVal	Comparison Value	UDINT	The target value set for comparison
		AddSetPat	+Set Pattern	DWORD	Output pattern setting when comparison conditions are met. Bit 00 to 31: Internal output 0 to 31
		AddRstPat	+Reset Pattern	DWORD	
		SubSetPat	-Set Pattern	DWORD	
		SubRstPat	-Reset Pattern	DWORD	



Additional Information

Precautions When Setting Comparison Data

- Comparison Stoppage When Comparison Value Reached

When the Counter Value reaches a comparison value, comparison stops for 1.5 ms. The other Counters, however, do not stop comparisons.

Set the Comparison Data considering the time when the comparison is stopped.

For example, for the Comparison table shown in the following diagram, approximately 4.8 counts occur during 1.5 ms when a 3.2 kHz pulse is input. This means that comparison does not occur for Counter Values 101, 102, 103, and 104. During this period, the Output set under the Output Pattern does not turn ON.

Comparison starts again after this 1.5 ms has elapsed.

At this time, the processing returns to the stoppage period and Comparison Data 1 and 2 are executed at the same time.

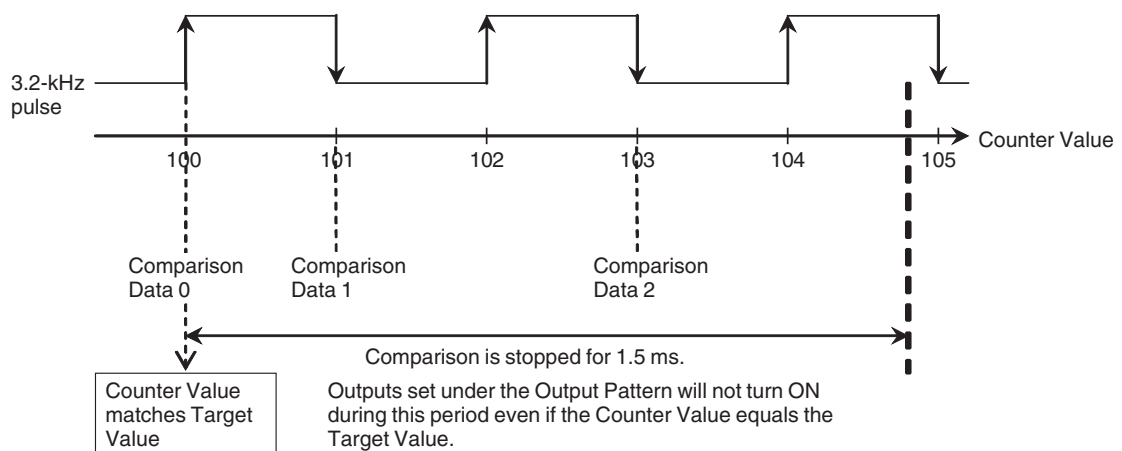

- Multiple Comparison Values of a specific Counter may not have the same value. The Unit will generate an error if multiple CV's have the same value (refer to section 5-2 Error Codes for more details).
- The Digital Outputs are Set/Reset in the chronological order of reaching the CV's. After reaching a (new) CV the (old) Unit Output Pattern is updated.
- In case for a CV both a Set and a Reset in one and the same counting direction for a specific Output are defined, the Reset has priority.
- The output can be set to Set, Reset, or *No Change* when a CV is reached both for incrementing and decrementing. Each time, the output pattern for both Counters will change in the order CVs are reached.
- Do not change the counting direction quickly near a CV. If the direction is changed near a CV, the direction in which the CV was reached (incrementing or decrementing) may be incorrectly detected.

● Reflecting Active/Not Active Comparison Values

A comparison condition is met when the Counter Value is equal to or larger than the comparison value. The comparison value active/inactive established status is reflected in the following device variable for CJ-series Unit (for input) for each Counter.

Name of device variable for CJ-series Unit	Type	Name	Function
*_Ch1_RngCmpDatSta	WORD	Ranges/Comparison Values active	The current status of the comparison conditions is shown. Bits 00 to 31 correspond to comparison conditions 0 to 31. Each bit shows 1 when the conditions are met and 0 when they are not.
*_Ch2_RngCmpDatSta			
*_Ch3_RngCmpDatSta			
*_Ch4_RngCmpDatSta			
*_Ch1_RngCmpSta0 to *_Ch1_RngCmpSta7	BOOL	Range/Comparison Value 0 to 7 active	Comparison 0 to 7 status 0: Comparison conditions not met 1: Comparison conditions met
*_Ch2_RngCmpSta0 to *_Ch2_RngCmpSta7			
*_Ch3_RngCmpSta0 to *_Ch3_RngCmpSta7			
*_Ch4_RngCmpSta0 to *_Ch4_RngCmpSta7			



Additional Information

- The above device variables function as Range value active status when in Range mode (Bits 0-3). See section 3-5-1 *Range Mode*.
- The Ranges/Comparison Active bit indicates whether the current Counter Value is larger than the CV or not. Therefore, if a Counter Value is preset larger than a CV, the bit changes to ON without crossing the CV. If the Counter Value crosses the CV in the reverse (CCW) direction, the bit does not change to ON.

● Enable / Disable Comparison Values

Every single comparison condition can be enabled or disabled. If comparison conditions are disabled (by default), no action will be taken even if the Counter Value reaches the CV. If comparison conditions are enabled, depending on the counting direction, the set or reset pattern is applied to the unit output pattern when the CV is reached. To enable or disable Counter comparison conditions, refer to the following device variables for CJ-series Unit (for setting):

Name of device variable for CJ-series Unit	Type	Name	Function
*_Ch1_RngCmpEnblCfg	DWORD	Range/Comparison Enable Data	Sets whether the range/comparison data is enabled or disabled. Bits 00-07: 0: Disable 1: Enable
*_Ch2_RngCmpEnblCfg			
*_Ch3_RngCmpEnblCfg			
*_Ch4_RngCmpEnblCfg			



Additional Information

- The above device variables function as Range value active status when in Range mode (Bits 0-3). See section 3-5-1 *Range Mode*.
- Bits set for non-existing Comparison or counter values will be ignored.

● Updating Unit Output Pattern with Preset or Reset Action

Besides by crossing CV's the Unit Output Pattern can also be updated by a Preset or a Reset action. To trigger a Preset or Reset action refer to section 3-4 *Controlling a Counter* and section 3-6 *Reset Signals*. Every Preset or Reset Action will then update the Unit Output Pattern according to the pre-defined Output Set and Output Reset Patterns. You can define an Output to be Set, Reset or reman Unchanged (similar as on reaching a Comparison Value).

Name of device variable for CJ-series Unit	Type	Name	Function
*_Ch1_OutSetPatCfg	DWORD	Output Set Pattern	They decide the set patterns for outputs 0 to 31. Bits 0 to 31 correspond to the outputs 0 to 31. When a bit is TRUE (1), the pattern is set for the corresponding output. When it is FALSE (0), no change is made for the output.
*_Ch2_OutSetPatCfg			
*_Ch3_OutSetPatCfg			
*_Ch4_OutSetPatCfg			
*_Ch1_OutRstPatCfg	DWORD	Output Reset Pattern	They decide the reset patterns for outputs 0 to 31. Bits 0 to 31 correspond to the outputs 0 to 31. When a bit is TRUE (1), the pattern is reset for the corresponding output. When it is FALSE (1), no change is made for the output.
*_Ch2_OutRstPatCfg			
*_Ch3_OutSetPatCfg			
*_Ch4_OutSetPatCfg			



Additional Information

In case for a Preset or Reset action for a specific Output both a Set and a Reset is defined the Reset has priority.

3-6 Reset Signals

For every Counter a reset of the Counter Value to zero can be triggered by the following Sources:

- Software Reset Bit
- Z-signal

In order for a Digital Input or the Z-Signal to trigger a reset, the Reset Enable Bit must be set to 1.

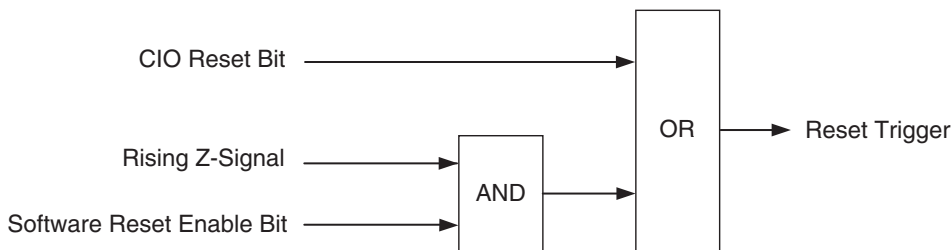

● Software Reset Bit as Reset Source

You can reset each Counter by using the device variable for CJ-series Unit (for output) below. These variables take priority over all other reset causes.

Name of device variable for CJ-series Unit	Type	Name	Function
*_Ch1_Rst	BOOL	Reset	Reset Counter
*_Ch2_Rst			0 to 1: Counter reset

● Z-Input Signal as Reset Source

To use the Z phase signal of an incremental encoder as a reset cause, first it is necessary to enable the Z phase signal resets with bits 03 to 00 of the following device variables for CJ-series Unit (for setting). Resets by Z phase signals can be set separately for each Counter.

Name of device variable for CJ-series Unit	Type	Name	Function
*_Ch1_ZOvfUdfCfg	WORD	Z-reset Mode, Overflow/Underflow error-code generation	Bits 03 to 00: Z phase reset
*_Ch2_ZOvfUdfCfg			16#0: No function
*_Ch3_ZOvfUdfCfg			16#1: Reset
*_Ch4_ZOvfUdfCfg			Bits 07 to 04: Overflow/underflow error setting
			16#0: Do not generate error codes.
			16#1: Generate error codes.
			Bits 15 to 08: 16#00

● Reset Enable Bit as Reset Enable Source

To execute a reset (or preset a Counter Value to 0) by using either Digital Input or a Z phase signal, it is necessary to set the following device variables for CJ-series Unit (for output) to 1.

Name of device variable for CJ-series Unit	Type	Name	Function
*_Ch1_RstEnbl	BOOL	Reset Enable	Reset Enable setting
*_Ch2_RstEnbl			0: Disable
*_Ch3_RstEnbl			1: Enabled
*_Ch4_RstEnbl			

3-7 Extra Functions

3-7-1 Hysteresis

An encoder can come to rest at a particular position and then “oscillate” around this position. This state means that the Counter Value fluctuates around a particular value. If, for example, a Range Limit is in this area of fluctuation, the corresponding Range would become active and inactive in the rhythm of these fluctuations. To prevent outputs from being switched ON and OFF by very small fluctuations, the Counter Unit offers the Hysteresis Function that can be configured for every Counter separately. You can assign Hysteresis in a range from 1 to 255 counts from which the Counter treats the fluctuation in the Counter Input Signal as a real change and outputs can be controlled accordingly.

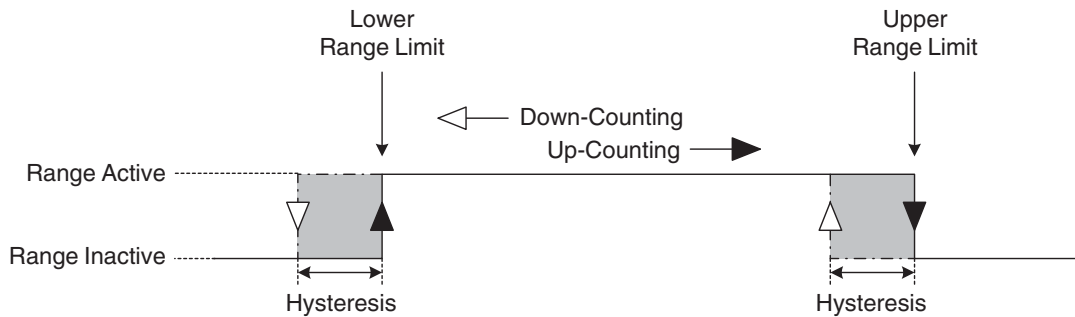

● Configuring Hysteresis

Name of device variable for CJ-series Unit	Type	Name	Function
*_Ch1_HystrsCfg	UINT	Hysteresis	Sets the hysteresis. For 0, the hysteresis function is disabled. Data range: 0 to 255 Pulses
*_Ch2_HystrsCfg			
*_Ch3_HystrsCfg			
*_Ch4_HystrsCfg			

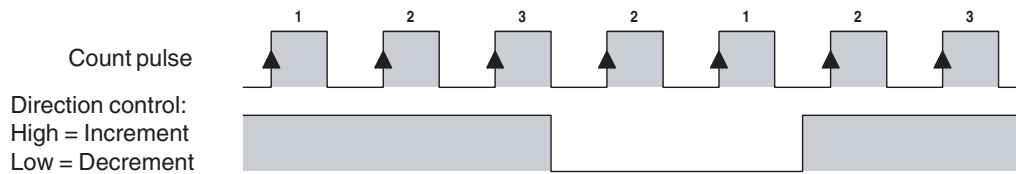

Additional Information

- The Hysteresis can only be applied to Units in Range Mode. If the Unit is in Comparison Mode you are able to configure Hysteresis yourself using Comparison Values.
- Do not set the origin (i.e., an actual value of 0) within the Hysteresis area.
- If the Counter is Preset, turn OFF the Hysteresis. If the Counter is Preset in the Hysteresis area, the Outputs will not be controlled correctly.

3-7-2 Initial Counter Value

Every Counter has device variables for CJ-series Unit for setting (double word) the initial Counter Values. The settings for these variables are transferred from the CPU Unit to this unit when the Unit restarts or the Controller is reset, including when the power is turned ON. The initial Counter Values overwrite the Counter Values and become the new Counter Values.

Name of device variable for CJ-series Unit	Type	Name	Function
*_Ch1_InitLinCtCfg	DINT	Initial Counter Value	Sets the initial Counter Value after unit setting data is transferred. –2,147,483,648 to 2,147,483,647 Pulses Used for Simple Counter or Linear Counter.
*_Ch2_InitLinCtCfg			
*_Ch3_InitLinCtCfg			
*_Ch4_InitLinCtCfg			
*_Ch1_InitRingCtCfg	UDINT	Initial Counter Value	Sets the initial Counter Value after unit setting data transferred. 0 to 4,294,967,295 Pulses Used for Circular Counter.
*_Ch2_InitRingCtCfg			
*_Ch3_InitRingCtCfg			
*_Ch4_InitRingCtCfg			

4

Exchanging Data with CPU

This section provides information on exchanging data between CJ1W-CTL41-E 4-Channel Counter Units and NJ-series CPU Units.

4

4-1 Overview	4-2
4-1-1 Data Flow	4-2
4-1-2 Unit Restart	4-4
4-1-3 Access from User Program	4-5
4-2 Memory Allocation	4-7
4-2-1 Memory Mapping	4-7
4-2-2 Allocating Ranges and Comparison Data	4-8
4-2-3 Details of Device Variables for CJ-series Unit (for input/output)	4-12
4-2-4 Details of Device Variables for CJ-series Unit (for setting)	4-16
4-2-5 Memory Allocation for Ranges	4-19
4-2-6 Memory Allocation for Comparison Data	4-20

4-1 Overview

4-1-1 Data Flow

The CPU Unit and the high-speed Counters exchange data via the I/O port created for the Counter Unit.

The table and figure below show the data exchange method for each data type.

Data exchange type

Unit data type	Data contents	AT specification destination	How to access from user program	Timing of data exchange
For Inputs For Outputs	Count start and stop, count value, status of each Counter, etc.	I/O port (for Inputs, Outputs)	Device variable for CJ-series Unit	At I/O refreshing *1
For Settings *2	External output control, external input function setting, settings for each Counter, etc.	I/O port (for Settings)		When the Controller is reset or the Unit restarts
Range data *2	Range data	Memory used for CJ-series Unit	User-defined Variable	
Comparison data *2	Comparison data			
Unit Restart Bit, etc.	Unit Restart Bit, etc.	None	System-defined variable	At I/O refreshing

*1 While *_UnitInitSta (Unit Busy) is 1, I/O is not refreshed. (For example, Counter Values are not refreshed during this time.)

*2 The setting data, range data, and comparison data are retained in the CPU Unit by the battery even during power interruptions.

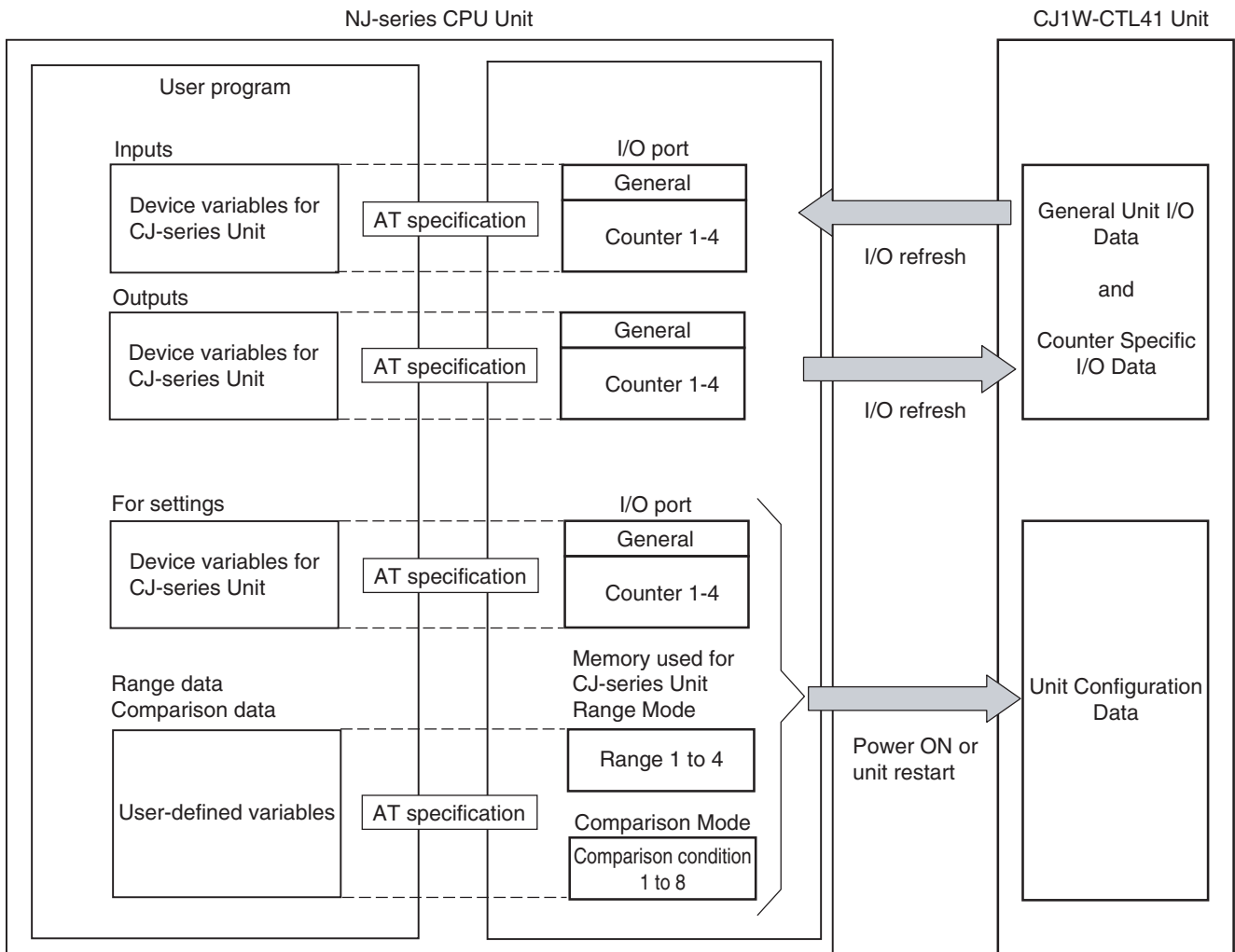

● Device variable for CJ-series Unit

These variables are used to exchange data between the user program and Special I/O Units.

Use device variables for CJ-series Units with AT specification for the I/O port. There are three types of variables: for input, for output, and for settings.

For details on allocation of device variables for CJ-series Units, refer to 4-1-3 *Access from User Program*.

● User-defined Variable

When a Counter is used in Range Mode or in Comparison Mode, user-defined variables are used to access, from the user program, the area in which the comparison data is set. An address of the data to be used as comparison data is set with the device variable for CJ-series Unit for setting. Use Sysmac Studio to specify the AT (allocation destination) in which comparison data is stored with user-defined variables.

For details, refer to 4-2-2 *Allocating Ranges and Comparison Data*.

AT specification of variables used to access these parameters/data is determined with the following.

Unit data type	AT specification destination	Setting Method
For Inputs For Outputs	I/O port (for Inputs, Outputs)	Created automatically when the Unit is registered to the Unit Configuration.
For Settings	I/O port (for Settings)	
Range data Comparison data	Memory used for CJ-series Unit	Set the allocated address with one of the following methods. (After this setting, reset the Controller or restart the Unit.) <ol style="list-style-type: none"> Set with Special Unit Setup Editing of Sysmac Studio and transfer the data setup file to the Unit. Set using the following device variables for CJ-series Unit: *_Ch#_MemAreaCfg, *_Ch#_MemAdrCfg (in data for Settings)

4-1-2 Unit Restart

To resume Unit operation after the contents of Unit settings are changed or after the cause of an error is eliminated, restart the Unit with the following method.

Any changes in the Unit settings are reflected after the Unit is restarted.

- Reset the Controller from Sysmac Studio.
- Restart from Sysmac Studio when initial settings parameters are transferred from Sysmac Studio.
- Cycle the Controller power to reset the Controller.
- Restart from the program by using a Reset Unit instruction.
- Restart by using a system-defined variable (restart by changing to TRUE).

Variable name

`_CJB_SIO**Restart`

The asterisks ** indicates Unit number 00 to 92.

4-1-3 Access from User Program

Various data are exchanged from the user program using the following variables.

Data type	Access method	Refresh timing
For settings	Device variable for CJ-series Units	When the Controller is reset or the unit restarts
For Outputs		I/O refresh
For Inputs		
Range	User-defined variable	When the Controller is reset or the unit restarts
Comparison data		

Allocating Device Variables for CJ-series Units

Use device variables for CJ-series Units with AT specification for the I/O port, which is explained below.

● I/O Port

An "I/O port" is a logical interface for data exchange by a CPU Unit with a Counter Unit or other Configuration Unit.

An I/O port has a unique pre-defined name for each unit model and function.

An I/O port is automatically created by preparing the Unit Configuration with Sysmac Studio.

● How to Specify Device Variables for CJ-series Units

Specify the AT specifications to I/O ports for device variables for CJ-series Units on the I/O Map of Sysmac Studio.

Specify the variable name for the AT specification with the following methods.

- 1** Select a variable already registered in the variable table
- 2** Input a new variable name
- 3** Automatically create a variable name with "Device variable creation"

When a name of device variable for CJ-series Unit is assigned with the method in 2 or 3, the variable input by Sysmac Studio is automatically registered in the variable table.

The following is the configuration of variable names created with automatic creation in step 3.

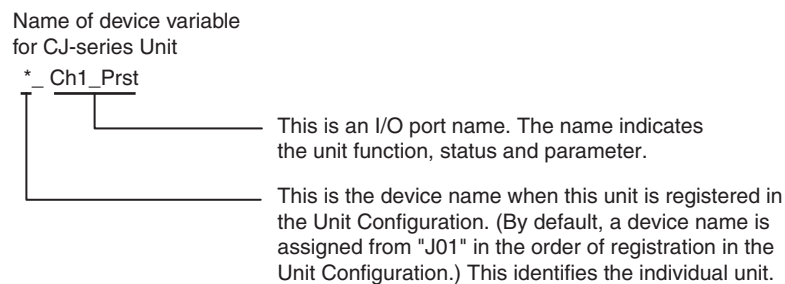



Additional Information

For details on creation of device variables for CJ-series Unit, refer to *Sysmac Studio Version 1 Operation Manual (Cat. No. W504)*.

In the explanations from here on, the device name automatically created is used as the device variable for CJ-series Unit, for example *_Ch1_Prst.

Allocating User-defined Variables

For the data used in Range Mode and Comparison Mode, it is necessary to allocate the variables used by the user-defined variables) to memory for CJ-series Unit.

Structure data types are pre-defined for comparison data used in Range Mode and Comparison Mode.

In order to use these data types, register the structure data type for Counter Units beforehand on the Unit Editor screen of Sysmac Studio.

With the Unit selected on the Unit Editor screen, right click, then select Register unit data type. The data type is registered and becomes usable.

To use this data, create user-defined variables using the above structures.

The user program uses the user-defined variables to control Counter Units.

With Counter Units, the following structure data types can be used for each comparison mode and Counter setting.

Comparison mode	Counter setting	Structure data type name
Range Mode	Linear Counter	_sCJCTL41_Ex_RngLin
	Circular Counter	_sCJCTL41_Ex_RngRing
Comparison Mode	Linear Counter	_sCJCTL41_Ex_CmpLin
	Circular Counter	_sCJCTL41_Ex_CmpRing

4-2 Memory Allocation

4-2-1 Memory Mapping

The data to be used when operating in Range mode or Comparison mode are allocated to any DM or EM Area (bank 0). This allocation method is called extended allocation. For details, refer to 4-2-2 *Allocating Ranges and Comparison Data*.

- For extended allocation

<(DM or EM) Area words allocated to Special I/O Unit>

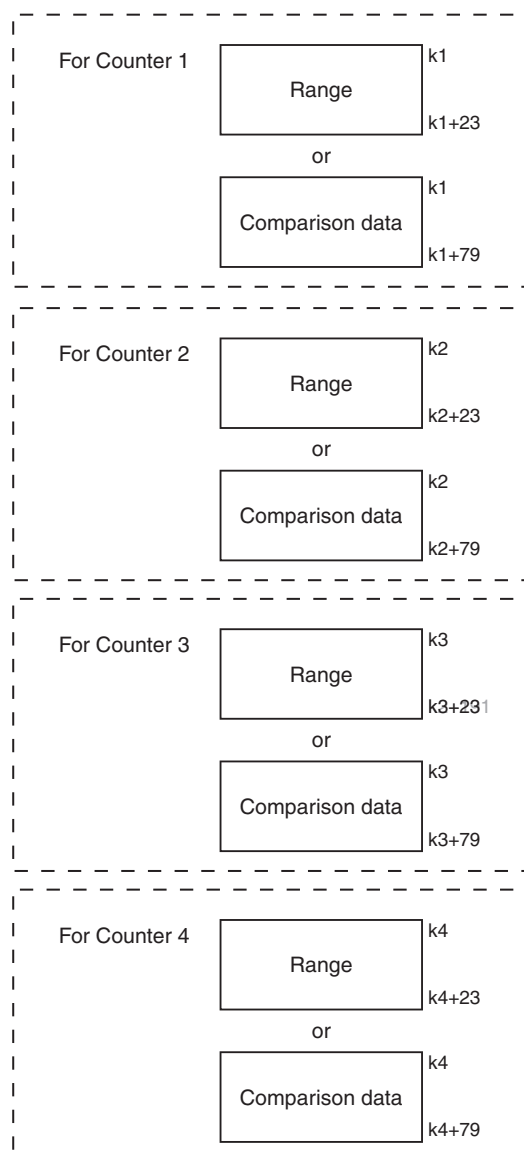

k_1, k_2, k_3, k_4 : Start address for comparison data areas for Counters 1-4. Specify the allocated address from I/O Memory Address screen in Special Unit Setup Editing of Sysmac Studio.

Data assigned to Counters 1-4 can be allocated to any DM or EM address. When this data is overlapped (duplicated), the Unit treats the overlap as a warning and "_IABlkOverlapSta" (IA Blocks overlap) becomes 1. But this is not an error. In other words, by defining one range data or comparison data and setting the same indirect address in more than one location ($k_1 = k_2$), that data can be shared by more than one Counter.

4-2-2 Allocating Ranges and Comparison Data

Ranges/Comparison data used in Range Mode or Comparison Mode is allocated in the following two steps.

- 1) Use Sysmac Studio to secure the area for the ranges/comparison data in a DM/EM Area (refer to *Indirect Address Specification*).
- 2) Store the ranges/comparison data in this area. Use user-defined variables to allocate the range/comparison data (refer to *Allocation to User-defined Variable*).

Indirect Address Specification

The Counter Unit can be used in Range Mode or Comparison Mode (refer to section 3-5-1 *Range Mode* and section 3-5-2 *Comparison Mode* for more information). The range or comparison data is allocated in DM or EM (bank 0). An indirect address that you can set for every Counter with a device variable for CJ-series Unit (for setting) points to the actual memory location in DM or EM where the range or comparison data of that Counter is stored.

● For a Unit in Range Mode

In Range Mode, indirect addresses can be used to define range for each Counter to be used. The number of ranges (M) defines the size of the range data block (size = $M \times 6$ words). When using multiple range items, in order to reserve exclusive memory, it is recommended to save the items consecutively starting from range 0. (For example, when range 0, 1, 2, 3, are set, this becomes M-1.)



Additional Information

If you do not want to allocate range data items consecutively, for example if you allocate two range data items (Data 0 and 15), the number of range items (M) must be set to 16. This is to avoid a setting error. The range data 1 to 14 must be enabled even if you do not intend to use them.

● For a Unit in Comparison Mode

In Comparison Mode Indirect Addressing can be used to define the comparison data per Counter that you want to use. The number of comparison data (M) defines the size of the Data block (size = $M \times 10$ words). If you want to use multiple CV's you are recommended to use consecutive comparison data starting from comparison data 0 (i.e. CV 0, 1, 2, 3 → M - 1) in order to save memory occupation.

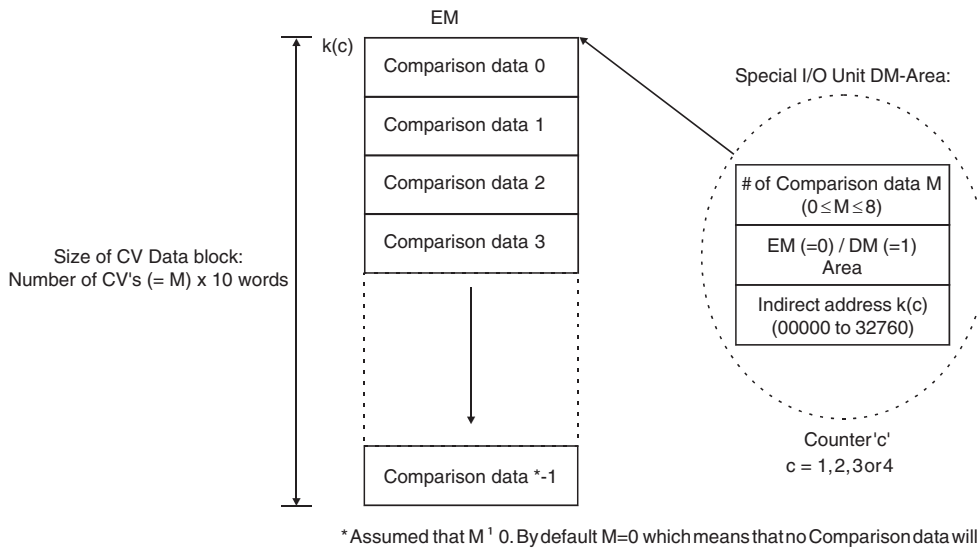

 **Additional Information**

If you do not want the Comparison data to be consecutive and only intend to use two Comparison data (e.g. Comparison data 0 and Comparison data 15) then you still have to define the number of Comparison data (M) to be 16. In order to prevent configuration errors from happening you should make sure that the Comparison data 1 to 14 is also valid, although you do not intend to use Comparison data 1 to 14.

● **Configuring Indirect Addressing**

An indirect address for the Unit in Range or Comparison Mode is specified with a device variable for a CJ-series Unit (for setting) for every Counter. You must specify the memory area (EM/DM) and the address (00000 to 32760) of the first word where the Range/Comparison data is to be stored. The size of the comparison data block is determined for every Counter depending on the number of ranges or comparison data. For every Range 6 words and for every Comparison data 10 words are allocated.

Range and comparison data is transferred from the CPU Unit as Unit setting data after the Unit Controller is reset or the Unit is restarted.

● **Example Range Mode**

With the Unit in Range Mode, if 2 range items (0 to 1) are set in Counter 1 and the data is allocated to the area starting with D0185, Sysmac Studio is used to set as follows.

Device variable for CJ-series Unit	Data type	R/W	Name	Set value
*_Ch#_NumRngCmpCfg	WORD	R/W	Number of Ranges/Comparison Values	16#0002
*_Ch#_MemAreaCfg	UINT	R/W	Memory Area	1 (DM)
*_Ch#_MemAdrCfg	DWORD	R/W	Memory Address	16#00001850

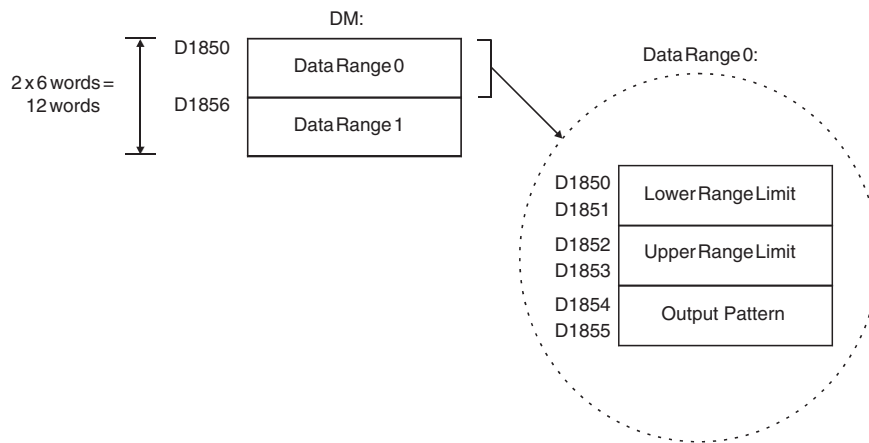

For an overview of all addresses related to range data refer to 4-2-5 Memory Allocation for Ranges

● Example Comparison Mode

With the Unit in Comparison Mode, if 5 comparison data (0 to 4) are set in Counter 1 and allocated to the area starting with EM00520, Sysmac Studio is used to set as follows.

Device variables for CJ-series Unit	Data type	R/W	Name	Setting value
*_Ch#_NumRngCmpCfg	WORD	R/W	Number of Ranges/Comparison Values	16#0005
*_Ch#_MemAreaCfg	UINT	R/W	Memory Area	0 (EM (bank 0))
*_Ch#_MemAdrCfg	DWORD	R/W	Memory Address	16#00000520

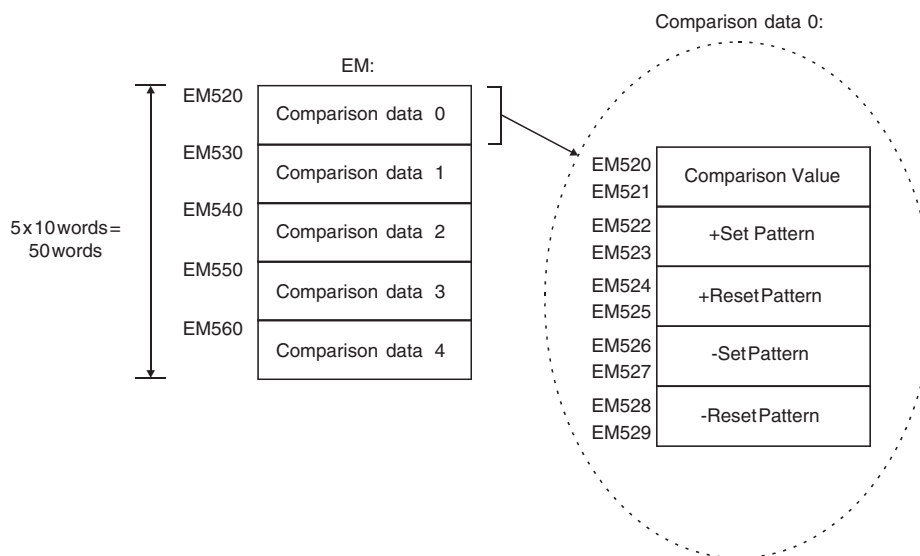

For an overview of all addresses related to Comparison Data refer to 4-2-6 Memory Allocation for Comparison Data.

Allocation to User-defined Variable

With Sysmac Studio, you can specify an AT (allocation destination) for the DM/EM area that you secured for ranges or comparison data by specifying indirect addresses (see page 4-8). With user-defined variables, it is possible to specify an arbitrary variable name. Once it is allocated, the ranges and comparison data can be read and written from Sysmac Studio or from a user program.

An actual example of allocation to user-defined variables is explained below.

Example: The 4 range data items shown below are allocated for Counter 1 using the structure data type "_sCJCTL41_Ex_RngLin" pre-defined for user-defined variable *CmpData*.

Setting the Device Variables for CJ-series Unit (for setting)

Device variable for CJ-series Unit	Data type	Name	Set value
*_Ch1_NumRngCmpCfg	WORD	Number of Ranges/Comparison data (BCD)	16#0004
*_Ch1_MemAreaCfg	UINT	Memory Area	1 (DM)
*_Ch1_MemAdrCfg	DWORD	Memory Address (BCD)	16#00001850

Note After this setting, reset the Controller or restart this Unit.

Data type definition

Structure data type name	Member	Data type	Name
_sCJCTL41_Ex_RngLin	LowLmt	DINT	Lower Limit Range
	UpLmt	DINT	Upper Limit Range
	OutPat	DWORD	Output Pattern

Register the structure data type for Counter Units beforehand on the Unit Editor screen of Sysmac Studio.

With the Unit selected on the Unit Editor screen, right click, then select *Register unit data type*. The data type is registered and becomes usable.

Variable tables

Variable name	Array	Data type
CmpData	[0..3]	_sCJCTL41_Ex_RngLin

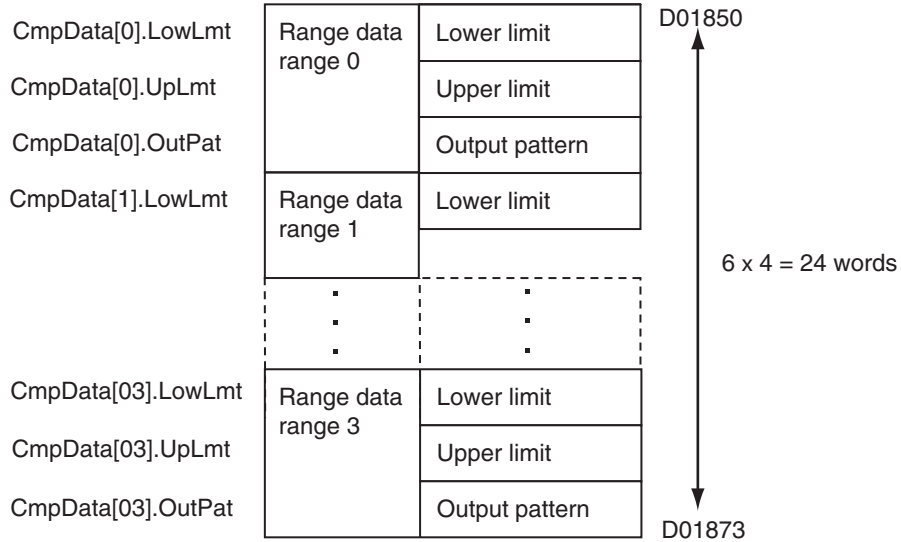

4-2-3 Details of Device Variables for CJ-series Unit (for input/output)

● **For Outputs**

Name of device variable for CJ-series Unit	Type	R/W	Name	Function
General				
*_RdNxtErr	BOOL	RW	Read Next Error	If multiple errors occurred at the same time, at the rising edge from 0 to 1, the next error is read out from the error list in this Unit and the error code is stored in *_ErrCode1 (error code 1) and *_ErrCode2 (error code 2). Factory value: 0
Counters 1-4 (*_CH# - '#' indicates counter number)				
*_Ch1_Enbl *_Ch2_Enbl *_Ch3_Enbl *_Ch4_Enbl	BOOL	RW	Open Gate*1 *2	0 to 1: Opens the gate (starts the count). Factory value: 0
*_Ch1_Dsbl *_Ch2_Dsbl *_Ch3_Dsbl *_Ch4_Dsbl	BOOL	RW	Close Gate*1 *2	0 to 1: Closes the gate (stops the count). Factory value: 0
*_Ch1_Prst *_Ch2_Prst *_Ch3_Prst *_Ch4_Prst	BOOL	RW	Preset*2	0 to 1: Loads preset values. Factory value: 0

Name of device variable for CJ-series Unit	Type	R/W	Name	Function
*_Ch1_Rst *_Ch2_Rst *_Ch3_Rst *_Ch4_Rst	BOOL	RW	Reset*2	0 to 1: Counter reset (Resets Counter Values to 0) Factory value: 0
*_Ch1_RstEnbl *_Ch2_RstEnbl *_Ch3_RstEnbl *_Ch4_RstEnbl	BOOL	RW	Reset Enable	0: Disable (factory value) 1: Enables Z phase input, Digital Input reset
*_Ch1_PrstLinCtVal *_Ch2_PrstLinCtVal *_Ch3_PrstLinCtVal *_Ch4_PrstLinCtVal	DINT	RW	Preset Value	Preset value Used for Simple Counter or Linear Counter. Data range: -2,147,483,648 to 2,147,483,647 Unit: Pulse Factory value: 0
*_Ch1_PrstRingCtVal *_Ch2_PrstRingCtVal *_Ch3_PrstRingCtVal *_Ch4_PrstRingCtVal	UDINT	RW	Preset Value	Preset value Used for Circular Counter. Data range: 0 to 4,294,967,295 Unit: Pulse Factory value: 0

Note The "*" at the head of the device variable name for CJ-series Unit is the device name when this Unit is registered in the Unit Configuration. By default, a device name is assigned from "J01" in the order of registration in the Unit Configuration

- *1 Initially, after the Controller is reset or the Unit is restarted, the Gate is closed. In order to start counting pulses, it is necessary to open the gate by setting Open Gate to 1 for the Counter to be used.
- *2 These bits may not be executed if they are ON for only one task period. Always keep these bits turned ON until the execution status changes in the corresponding bits (refer to the section on device variables for CJ-series Unit for input).

● For Inputs

Name of device variable for CJ-series Unit	Type	R/W	Name	Function
General				
*_OutStaDat	DWORD	R	Output Status	The current statuses of external and internal output (total of 32) are all displayed. 0: FALSE 1: TRUE Bit 00: Internal output 0 Bit 01: Internal output 1 --- Bit 31: Internal output 31 This variable is used to process output signal statuses collectively. Data range: 16#00000000 to 16#FFFFFFFF
*_OutSta0	BOOL	R	Soft Output 0 Status	1: TRUE, 0: FALSE
*_OutSta1	BOOL	R	Soft Output 1 Status	1: TRUE, 0: FALSE
~~				
*_OutSta31	BOOL	R	Soft Output 31 Status	1: TRUE, 0: FALSE
*_ErrCode1	WORD	R	Error Code 1	For details, refer to 5-2 Error Codes. Data range: 16#0000 to 16#FFFF
*_ErrCode2	WORD	R	Error Code 2	For details, refer to 5-2 Error Codes. Data range: 16#0000 to 16#FFFF
*_GlbIErr	BOOL	R	Global Error	1: Shows that one or more error has occurred. These error codes are stored in the error list in this unit. 0: Normal
*_UnitInItSta	BOOL	R	Unit Busy	1: Unit initialization processing underway*2 0: Other than the above
*_IABlkOverlapSta	BOOL	R	IA Blocks overlap	1: Shows that range/comparison data is duplicated in the CPU Unit I/O memory. 0: Other than the above
Counter 1-4 (*_CH# - '# indicates counter number)				
*_Ch1_RngCmpDatSta *_Ch2_RngCmpDatSta *_Ch3_RngCmpDatSta *_Ch4_RngCmpDatSta	WORD	R	Ranges/Comparison Values active	Shows the current status of all the comparison conditions. Bits 00 to 07 correspond to Range/Comparison conditions 0 to 7. Each bit shows 1 if the condition is met, or 0 if the condition is not met. Data range: 16#0000 to 16#00FF

Name of device variable for CJ-series Unit	Type	R/W	Name	Function
*_Ch1_RngCmpSta0 *_Ch2_RngCmpSta0 *_Ch3_RngCmpSta0 *_Ch4_RngCmpSta0	BOOL	R	Ranges/Comparison Values 0 active	1: Met, 0: Not met
*_Ch1_RngCmpSta1 *_Ch2_RngCmpSta1 *_Ch3_RngCmpSta1 *_Ch4_RngCmpSta1	BOOL	R	Ranges/Comparison Values 1 active	1: Met, 0: Not met
*_Ch1_RngCmpSta2 *_Ch2_RngCmpSta2 *_Ch3_RngCmpSta2 *_Ch4_RngCmpSta2	BOOL	R	Ranges/Comparison Values 2 active	1: Met, 0: Not met
*_Ch1_RngCmpSta3 *_Ch2_RngCmpSta3 *_Ch3_RngCmpSta3 *_Ch4_RngCmpSta3	BOOL	R	Ranges/Comparison Values 3 active	1: Met, 0: Not met
*_Ch1_RngCmpSta4 *_Ch2_RngCmpSta4 *_Ch3_RngCmpSta4 *_Ch4_RngCmpSta4	BOOL	R	Comparison Values 4 active	1: Met, 0: Not met
*_Ch1_RngCmpSta5 *_Ch2_RngCmpSta5 *_Ch3_RngCmpSta5 *_Ch4_RngCmpSta5	BOOL	R	Comparison Values 5 active	1: Met, 0: Not met
*_Ch1_RngCmpSta6 *_Ch2_RngCmpSta6 *_Ch3_RngCmpSta6 *_Ch4_RngCmpSta6	BOOL	R	Comparison Values 6 active	1: Met, 0: Not met
*_Ch1_RngCmpSta7 *_Ch2_RngCmpSta7 *_Ch3_RngCmpSta7 *_Ch4_RngCmpSta7	BOOL	R	Comparison Values 7 active	1: Met, 0: Not met
*_Ch1_LinCtVal *_Ch2_LinCtVal *_Ch3_LinCtVal *_Ch4_LinCtVal	DINT	R	Counter Value	Shows the encoder Counter Value. Used for Simple Counter or Linear Counter. Data range: –2,147,483,648 to 2,147,483,647 Unit: Pulse
*_Ch1_RingCtVal *_Ch2_RingCtVal *_Ch3_RingCtVal *_Ch4_RingCtVal	UDINT	R	Counter Value	Shows the encoder Counter Value. Used for Circular Counter. Data range: 0 to 4,294,967,295 Unit: Pulse
*_Ch1_CtOvf *_Ch2_CtOvf *_Ch3_CtOvf *_Ch4_CtOvf	BOOL	R	Counter Overflow	1: The upper count limit of the Linear Counter is reached.

Name of device variable for CJ-series Unit	Type	R/W	Name	Function
*_Ch1_CtUdf *_Ch2_CtUdf *_Ch3_CtUdf *_Ch4_CtUdf	BOOL	R	Counter Underflow	1: The lower count limit of the Linear Counter is reached.
*_Ch1_CtRun *_Ch2_CtRun *_Ch3_CtRun *_Ch4_CtRun	BOOL	R	Counter Running/Gate Open	1: During Counter operation/while gate open 0: While Counter stopped/while gate closed
*_Ch1_CntDir *_Ch2_CntDir *_Ch3_CntDir *_Ch4_CntDir	BOOL	R	Counting Direction	1: Count up 0: Count down
*_Ch1_PrstSta *_Ch2_PrstSta *_Ch3_PrstSta *_Ch4_PrstSta	BOOL	R	Preset Activated*1	1: The presets are executed.
*_Ch1_RstSta *_Ch2_RstSta *_Ch3_RstSta *_Ch4_RstSta	BOOL	R	Reset Activated*1	1: A reset is executed.
*_Ch1_ZSig *_Ch2_ZSig *_Ch3_ZSig *_Ch4_ZSig	BOOL	R	Z-signal Activated*1	1: A Z signal is input.

*1 The Reset, Preset, and Z-signal Activated turn ON for at least one CPU Unit task period after the occurrence of a pulse that was detected since the previous I/O refresh.

*2 During initialization, the Unit turns ON for approximately 120 ms.

4-2-4 Details of Device Variables for CJ-series Unit (for setting)

Setting data can be set with the following two methods.

- Set from Edit Special Unit Settings of Sysmac Studio.
- Set the values for device variables for CJ-series Units.

Unit settings are reflected only when the Controller is reset, or when the Unit restarts. The data setup file is retained in the CPU Unit by the battery even during power interruptions.



Precautions for Safe Use

When the program is transferred, data set in Special Unit Setup Editing of Sysmac Studio will be reflected in the device variable for CJ-series Unit in the initial settings data. At the time of transfer, Sysmac Studio checks whether or not the unit must be restarted. Restart the unit after confirming the safety of the connected destination.

Name of device variable for C-J-series Unit	Type	R/W	Name	Function
General				
*_OutCtlMdCfg	WORD	R/W	Output Control Mode/AND/OR Counter Output Patterns	Bits 00 to 07: Output Control Mode Selects the Output Control Mode. 16#00: Range Mode (factory value) 16#01: Comparison Mode Bits 08 to 15: Counter output pattern AND/OR selection For Range Mode, selects whether the Counter output pattern is logically OR or AND. 16#00: OR (factory value) 16#01: AND
Counters 1-4 (*_CH# - '#' indicates counter number)				
*_Ch1_CtTypCfg *_Ch2_CtTypCfg *_Ch3_CtTypCfg *_Ch4_CtTypCfg	UINT	R/W	Counter Type	Sets the Counter type. 0: Circular Counter (factory value) 1: Linear Counter
*_Ch1_SigTypCfg *_Ch2_SigTypCfg *_Ch3_SigTypCfg *_Ch4_SigTypCfg	UINT	R/W	Signal Type	Sets the input type. 0: Phase differential (multiplication 1) (factory value) 1: Phase differential (multiplication 2) 2: Phase differential (multiplication 4) 4: Up & down pulse 8: Pulse & direction
*_Ch1_ZOVfUdfCfg *_Ch2_ZOVfUdfCfg *_Ch3_ZOVfUdfCfg *_Ch4_ZOVfUdfCfg	WORD	R/W	Z-reset Mode/Overflow/Underflow error-code generation	Bits 00 to 03: This sets the Z phase input signal function. 16#0: No function (factory value) 16#1: Reset (Z phase input signal rising edge) Bits 04 to 07: Sets whether or not overflow/underflow error codes are created. 16#0: Error codes are not created (The overflow/underflow bit is set and the output retains the previous status.) (factory value) 16#1: Error codes are created. (Error codes are reported and all output is switched OFF.) Bits 08 to 15: Use with 0 (factory value).
*_Ch1_UpCtLmtCfg *_Ch2_UpCtLmtCfg *_Ch3_UpCtLmtCfg *_Ch4_UpCtLmtCfg	UDINT	R/W	Upper Count Limit Circular/Linear	Sets the circular/Linear Counters upper count limit. Data range: 0 to 4,294,967,295 Unit: Pulse Factory value: 0
*_Ch1_LowCtLmtCfg *_Ch2_LowCtLmtCfg *_Ch3_LowCtLmtCfg *_Ch4_LowCtLmtCfg	DINT	R/W	Lower Count Limit Linear	Sets the Linear Counter lower count limit. Data range: -2,147,483,648 to 0 Unit: Pulse Factory value: 0

Name of device variable for CJ-series Unit	Type	R/W	Name	Function
*_Ch1_InitLinCtCfg *_Ch2_InitLinCtCfg *_Ch3_InitLinCtCfg *_Ch4_InitLinCtCfg	DINT	R/W	Initial Count Value	Sets the initial Counter Value after unit setting data is transferred. Used for Simple Counter or Linear Counter. Data range: -2,147,483,648 to 2,147,483,647 Unit: Pulse Factory value: 0
*_Ch1_InitRingCtCfg *_Ch2_InitRingCtCfg *_Ch3_InitRingCtCfg *_Ch4_InitRingCtCfg	UDINT	R/W	Initial Count Value	Sets the initial Counter Value after unit setting data is transferred. Used for Circular Counter. Data range: 0 to 4,294,967,295 Unit: Pulse Factory value: 0
*_Ch1_RngCmpEnblCfg *_Ch2_RngCmpEnblCfg *_Ch3_RngCmpEnblCfg *_Ch4_RngCmpEnblCfg	DWORD	R/W	Range/Comparison Enable Data	Sets whether the range/comparison data is enabled or disabled. Bits 0 to 31 correspond to comparison data 00 to 31. Each bit is enabled for 1 and disabled for 0. Data range: 16#00000000 to 16#FFFFFFF Factory value: 0
*_Ch1_OutSetPatCfg *_Ch2_OutSetPatCfg *_Ch3_OutSetPatCfg *_Ch4_OutSetPatCfg	DWORD	R/W	Output Set Pattern	Sets the output (0 to 31) set pattern. Bits 0 to 31 correspond to output 00 to 31. Each bit is set for 1 and no change for 0. Data range: 16#00000000 to 16#FFFFFFF Factory value: 0
*_Ch1_OutRstPatCfg *_Ch2_OutRstPatCfg *_Ch3_OutRstPatCfg *_Ch4_OutRstPatCfg	DWORD	R/W	Output Reset Pattern	Sets the output (0 to 31) reset pattern. Bits 0 to 31 correspond to output 00 to 31. Each bit is reset for 1 and no change for 0. Data range: 16#00000000 to 16#FFFFFFF Factory value: 0
*_Ch1_HystrsCfg *_Ch2_HystrsCfg *_Ch3_HystrsCfg *_Ch4_HystrsCfg	UINT	R/W	Hysteresis	Sets the hysteresis. For 0, the hysteresis function is disabled. Data range: 0 to 255 Unit: Pulse Factory value: 0
*_Ch1_NumRngCmpCfg *_Ch2_NumRngCmpCfg *_Ch3_NumRngCmpCfg *_Ch4_NumRngCmpCfg	WORD	R/W	Number of Ranges/Comparison Values	Sets the number of ranges/comparison values as a BCD. Data range: 16#0000 to 0032 Factory value: 16#0000
*_Ch1_MemAreaCfg *_Ch2_MemAreaCfg *_Ch3_MemAreaCfg *_Ch4_MemAreaCfg	UINT	R/W	Memory Area	This sets the area type for storing the range/comparison data. 0: EM (factory value) 1: DM
*_Ch2_MemAdrCfg *_Ch3_MemAdrCfg *_Ch3_MemAdrCfg *_Ch4_MemAdrCfg	DWORD	R/W	Memory Address	This sets the start address (EM/DM) for storing the range/comparison data as a BCD. Data range: 16#00000000 to 00032760 Factory value: 16#0000

*1 Set to "0" and turn OFF *Hysteresis* to use the Preset Function.

*2 Sets the beginning (k1) of the *Range Data* or *Comparison Data*.

4-2-5 Memory Allocation for Ranges

Range data are set in the user-defined variable. Refer to *Allocation to User-defined Variable* on page 11 for more information.

Two types of structure data are prepared beforehand for range data user-defined variables: one type for Linear Counters and one type for Circular Counters.

Register the structure data type for Counter Units beforehand on the Unit Editor screen of Sysmac Studio.

With the Unit selected on the Unit Editor screen, right click, then select *Register unit data type*. The data type is registered and becomes usable.

Use these structures to define user-defined variables.

Data type (name)	Member	Data type	Name
_sCJCTL41_Ex_RngLin	LowLmt	DINT	Lower Limit Range
	UpLmt	DINT	Upper Limit Range
	OutPat	DWORD	Output Pattern
_sCJCTL41_Ex_RngRing	LowLmt	UDINT	Lower Limit Range
	UpLmt	UDINT	Upper Limit Range
	OutPat	DWORD	Output Pattern

The table below shows an example of range allocation when the range data user-defined variables are defined as follows.

c1D for Counter 1 (array[0..3] of _sCJCTL41_Ex_RngLin) (Linear Counter, 4 ranges (maximum))

c2D for Counter 2 (array[0..3] of _sCJCTL41_Ex_RngLin) (Linear Counter, 4 ranges (maximum))

c3D for Counter 3 (array[0..3] of _sCJCTL41_Ex_RngRing) (Circular Counter, 4 ranges (maximum))

c4D for Counter 4 (array[0..3] of _sCJCTL41_Ex_RngRing) (Circular Counter, 4 ranges (maximum))

Variable name	Data type	Item	Function
Counter 1			
c1D[0]	_sCJCTL41_Ex_RngLin	Range 0	
c1D[0].LowLmt	DINT	Range 0 Lower Limit	Range 0 lower limit
c1D[0].UpLmt	DINT	Range 0 Upper Limit	Range 0 upper limit
c1D[0].OutPat	DWORD	Range 0 Output Pattern	Range 0 output pattern*
c1D[1]	_sCJCTL41_Ex_RngLin	Range 1	Range 1 lower limit/upper limit values and output pattern
c1D[2]	_sCJCTL41_Ex_RngLin	Range 2	Range 2 lower limit/upper limit values and output pattern
c1D[3]	_sCJCTL41_Ex_RngLin	Range 3	Range 3 lower limit/upper limit values and output pattern

Variable name	Data type	Item	Function
Counter 2			
c2D[0]	_sCJCTL41_Ex_RngLin	Range 0	
c2D[0].LowLmt	UDINT	Range 0 Lower Limit	Range 0 lower limit
c2D[0].UpLmt	UDINT	Range 0 Upper Limit	Range 0 upper limit

Variable name	Data type	Item	Function
c2D[0].OutPat	DWORD	Range 0 Output Pattern	Range 0 output pattern*
c2D[1]	_sCJCTL41_Ex_RngLin	Range 1	Range 1 lower limit/upper limit values and output pattern
c2D[2]	_sCJCTL41_Ex_RngLin	Range 2	Range 2 lower limit/upper limit values and output pattern
c2D[3]	_sCJCTL41_Ex_RngLin	Range 3	Range 3 lower limit/upper limit values and output pattern

Variable name	Data type	Item	Function
Counter 3			
c3D[0]	_sCJCTL41_Ex_RngRing	Range 0	
c3D[0].LowLmt	UDINT	Range 0 Lower Limit	Range 0 lower limit
c3D[0].UpLmt	UDINT	Range 0 Upper Limit	Range 0 upper limit
c3D[0].OutPat	DWORD	Range 0 Output Pattern	Range 0 output pattern*
c3D[1]	_sCJCTL41_Ex_RngRing	Range 1	Range 1 lower limit/upper limit values and output pattern
c3D[2]	_sCJCTL41_Ex_RngRing	Range 2	Range 2 lower limit/upper limit values and output pattern
c3D[3]	_sCJCTL41_Ex_RngRing	Range 3	Range 3 lower limit/upper limit values and output pattern

Variable name	Data type	Item	Function
Counter 4			
c4D[0]	_sCJCTL41_Ex_RngRing	Range 0	
c4D[0].LowLmt	UDINT	Range 0 Lower Limit	Range 0 lower limit
c4D[0].UpLmt	UDINT	Range 0 Upper Limit	Range 0 upper limit
c4D[0].OutPat	DWORD	Range 0 Output Pattern	Range 0 output pattern*
c4D[1]	_sCJCTL41_Ex_RngRing	Range 1	Range 1 lower limit/upper limit values and output pattern
c4D[2]	_sCJCTL41_Ex_RngRing	Range 2	Range 2 lower limit/upper limit values and output pattern
c4D[3]	_sCJCTL41_Ex_RngRing	Range 3	Range 3 lower limit/upper limit values and output pattern

* For details on output patterns, refer to section 3-5-1 Range Mode.

4-2-6 Memory Allocation for Comparison Data

Comparison data are set in the user-defined variable. Refer to *Allocation to User-defined Variable on page 11* for more information.

Two types of structure data are prepared beforehand for comparison data user-defined variables: one type for Linear Counters and one type for Circular Counters.

Register the structure data type for Counter Units beforehand on the Unit Editor screen of Sysmac Studio.

With the Unit selected on the Unit Editor screen, right click, then select *Register unit data type*. The data type is registered and becomes usable.

Use these structures to define user-defined variables.

Data type (name)	Member	Data type	Name
_sCJCTL41_Ex_CmpLin	CmpVal	DINT	Comparison value
	AddSetPat	DWORD	+Set pattern
	AddRstPat	DWORD	+Reset pattern
	SubSetPat	DWORD	-Set pattern
	SubRstPat	DWORD	-Reset pattern
_sCJCTL41_Ex_CmpRing	CmpVal	UDINT	Comparison value
	AddSetPat	DWORD	+Set pattern
	AddRstPat	DWORD	+Reset pattern
	SubSetPat	DWORD	-Set pattern
	SubRstPat	DWORD	-Reset pattern

The table below shows an example of comparison data allocation when the comparison data user-defined variables are defined as follows.

- c1D for Counter 1 (array[0..7] of _sCJCTL41_Ex_CmpLin)
(Linear Counter, 8 comparison data (maximum))
- c2D for Counter 2 (array[0..7] of _sCJCTL41_Ex_CmpLin)
(Linear Counter, 8 comparison data (maximum))
- c3D for Counter 3 (array[0..7] of _sCJCTL41_Ex_CmpRing)
(Circular Counter, 8 comparison data (maximum))
- c4D for Counter 4 (array[0..7] of _sCJCTL41_Ex_CmpRing)
(Circular Counter, 8 comparison data (maximum))

Variable name	Data type	Item	Function
Counter 1			
c1D[0]	_sCJCTL41_Ex_CmpLin	Comparison data 0	
c1D[0].CmpVal	DINT	Comparison data 0 Comparison value	Comparison data 0 Comparison value
c1D[0].AddSetPat	DWORD	Comparison data 0 +Set Pattern	Comparison data 0 output +set pattern*
c1D[0].AddRstPat	DWORD	Comparison data 0 +Reset Pattern	Comparison data 0 output +reset pattern*
c1D[0].SubSetPat	DWORD	Comparison data 0 -Set Pattern	Comparison data 0 output -set pattern*
c1D[0].SubRstPat	DWORD	Comparison data 0 -Reset Pattern	Comparison data 0 output -reset pattern*
c1D[1]	_sCJCTL41_Ex_CmpLin	Comparison data 1	Comparison value, output (+/-) set/reset pattern
c1D[2]	_sCJCTL41_Ex_CmpLin	Comparison data 2	Comparison value, output (+/-) set/reset pattern
c1D[3]	_sCJCTL41_Ex_CmpLin	Comparison data 3	Comparison value, output (+/-) set/reset pattern
c1D[4]	_sCJCTL41_Ex_CmpLin	Comparison data 4	Comparison value, output (+/-) set/reset pattern

Variable name	Data type	Item	Function
c1D[5]	_sCJCTL41_Ex_CmpLin	Comparison data 5	Comparison value, output (+/-) set/reset pattern
c1D[6]	_sCJCTL41_Ex_CmpLin	Comparison data 6	Comparison value, output (+/-) set/reset pattern
c1D[7]	_sCJCTL41_Ex_CmpLin	Comparison data 7	Comparison value, output (+/-) set/reset pattern

Variable name	Data type	Item	Function
Counter 2			
c2D[0]	_sCJCTL41_Ex_CmpLin	Comparison data 0	
c2D[0].CmpVal	DINT	Comparison data 0 Comparison value	Comparison data 0 Comparison value
c2D[0].AddSetPat	DWORD	Comparison data 0 +Set Pattern	Comparison data 0 output +set pattern*
c2D[0].AddRstPat	DWORD	Comparison data 0 +Reset Pattern	Comparison data 0 output +reset pattern*
c2D[0].SubSetPat	DWORD	Comparison data 0 -Set Pattern	Comparison data 0 output -set pattern*
c2D[0].SubRstPat	DWORD	Comparison data 0 -Reset Pattern	Comparison data 0 output -reset pattern*
c2D[1]	_sCJCTL41_Ex_CmpLin	Comparison data 1	Comparison value, output (+/-) set/reset pattern
c2D[2]	_sCJCTL41_Ex_CmpLin	Comparison data 2	Comparison value, output (+/-) set/reset pattern
c2D[3]	_sCJCTL41_Ex_CmpLin	Comparison data 3	Comparison value, output (+/-) set/reset pattern
c2D[4]	_sCJCTL41_Ex_CmpLin	Comparison data 4	Comparison value, output (+/-) set/reset pattern
c2D[5]	_sCJCTL41_Ex_CmpLin	Comparison data 5	Comparison value, output (+/-) set/reset pattern
c2D[6]	_sCJCTL41_Ex_CmpLin	Comparison data 6	Comparison value, output (+/-) set/reset pattern
c2D[7]	_sCJCTL41_Ex_CmpLin	Comparison data 7	Comparison value, output (+/-) set/reset pattern

Variable name	Data type	Item	Function
Counter 3			
c3D[0]	_sCJCTL41_Ex_CmpRing	Comparison data 0	
c3D[0].CmpVal	DINT	Comparison data 0 Comparison value	Comparison data 0 Comparison value
c3D[0].AddSetPat	DWORD	Comparison data 0 +Set Pattern	Comparison data 0 output +set pattern*
c3D[0].AddRstPat	DWORD	Comparison data 0 +Reset Pattern	Comparison data 0 output +reset pattern*
c3D[0].SubSetPat	DWORD	Comparison data 0 -Set Pattern	Comparison data 0 output -set pattern*
c3D[0].SubRstPat	DWORD	Comparison data 0 -Reset Pattern	Comparison data 0 output -reset pattern*

Variable name	Data type	Item	Function
c3D[1]	_sCJCTL41_Ex_CmpRing	Comparison data 1	Comparison value, output (+/-) set/reset pattern
c3D[2]	_sCJCTL41_Ex_CmpRing	Comparison data 2	Comparison value, output (+/-) set/reset pattern
c3D[3]	_sCJCTL41_Ex_CmpRing	Comparison data	Comparison value, output (+/-) set/reset pattern
c3D[4]	_sCJCTL41_Ex_CmpRing	Comparison data 4	Comparison value, output (+/-) set/reset pattern
c3D[5]	_sCJCTL41_Ex_CmpRing	Comparison data 5	Comparison value, output (+/-) set/reset pattern
c3D[6]	_sCJCTL41_Ex_CmpRing	Comparison data 6	Comparison value, output (+/-) set/reset pattern
c3D[7]	_sCJCTL41_Ex_CmpRing	Comparison data 7	Comparison value, output (+/-) set/reset pattern

Variable name	Data type	Item	Function
Counter 4			
c4D[0]	_sCJCTL41_Ex_CmpRing	Comparison data 0	
c4D[0].CmpVal	DINT	Comparison data 0 Comparison value	Comparison data 0 Comparison value
c4D[0].AddSetPat	DWORD	Comparison data 0 +Set Pattern	Comparison data 0 output +set pattern*
c4D[0].AddRstPat	DWORD	Comparison data 0 +Reset Pattern	Comparison data 0 output +reset pattern*
c4D[0].SubSetPat	DWORD	Comparison data 0 -Set Pattern	Comparison data 0 output -set pattern*
c4D[0].SubRstPat	DWORD	Comparison data 0 -Reset Pattern	Comparison data 0 output -reset pattern*
c4D[1]	_sCJCTL41_Ex_CmpRing	Comparison data 1	Comparison value, output (+/-) set/reset pattern
c4D[2]	_sCJCTL41_Ex_CmpRing	Comparison data 2	Comparison value, output (+/-) set/reset pattern
c4D[3]	_sCJCTL41_Ex_CmpRing	Comparison data	Comparison value, output (+/-) set/reset pattern
c4D[4]	_sCJCTL41_Ex_CmpRing	Comparison data 4	Comparison value, output (+/-) set/reset pattern
c4D[5]	_sCJCTL41_Ex_CmpRing	Comparison data 5	Comparison value, output (+/-) set/reset pattern
c4D[6]	_sCJCTL41_Ex_CmpRing	Comparison data 6	Comparison value, output (+/-) set/reset pattern
c4D[7]	_sCJCTL41_Ex_CmpRing	Comparison data 7	Comparison value, output (+/-) set/reset pattern

* For details on set and reset patterns, refer to *Configuration and Operation in Comparison Mode* on page 22.

5

Error Processing, Maintenance and Inspection

This section provides details of the CJ1W-CTL41-E 4-Channel Counter Unit's error indicators and error codes and guidelines for maintenance and inspection of the Unit.

5-1 Error Indicators	5-2
5-1-1 Errors during initial processing	5-2
5-1-2 Errors during normal operation	5-2
5-2 Error Codes	5-3
5-2-1 DM-configuration errors	5-4
5-2-2 Overflow/Underflow errors	5-5
5-2-3 System Errors	5-5
5-2-4 Preset Error	5-5
5-3 Event Log	5-7
5-3-1 Overview of the Event Logs	5-7
5-3-2 Error Table	5-7
5-3-3 Error Descriptions	5-8
5-4 Maintenance and Inspection	5-10
5-4-1 Cleaning	5-10
5-4-2 Routine Inspections	5-10

5-1 Error Indicators

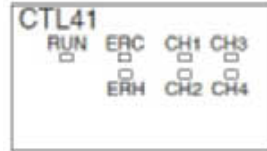

The RUN-, ERC-, and ERH indicators at the front panel of the Counter Unit, display the following errors.

5-1-1 Errors during initial processing

RUN	ERC	ERH	Error	Probable cause	Remedy
OFF	OFF	ON	Setup error	Incorrect Unit number Cyclic initial error	Set correct Unit number and turn ON the power again
OFF	ON	OFF	DM-configuration error	Invalid contents of the settings for device variables for CJ-series Unit (for setting)	Check the error code with *_ErrCode1 (Error code 1) and *_ErrCode2 (Error code 2), set the device variables for CJ-series Unit (for setting) (unit setting) again correctly. Restart the Unit or reset the Controller. Refer to 5-2 Error Codes for more information on error codes and how to clear them.
			Unit error	An error occurred in the Unit's EEPROM, RAM or CPU or a system software error occurred	Restart the Unit or reset the Controller. If errors reoccur, then replace the High-speed Counter Unit.
OFF	ON	ON	Unit classification error	The Unit classification was set incorrectly	Replace the Counter Unit
OFF	OFF	OFF	Watch Dog Timer time-out error	The Unit's Watch Dog Timer has timed out	Turn OFF and then ON the power again. If errors reoccurs, then replace the Counter Unit

5-1-2 Errors during normal operation

RUN	ERC	ERH	Error	Probable cause	Remedy
ON	ON	OFF	Unit error	<ul style="list-style-type: none"> • Overflow or underflow of Linear Counter. • Preset error 	Check the Error Code(s) in *_ErrCode1 (error code 1) and *_ErrCode2 (Error code 2). Apply appropriate remedy according to the cause of the error. Refer to 5-2 Error Codes for more information on error codes and how to clear them.
ON	OFF	ON	System error	CPU error	Check the CPU for errors and apply the appropriate remedy according to the cause of the error.

5-2 Error Codes

● Reporting errors

Errors occurring in the Counter Unit are divided into the following 4 types.

- Allocated DM area setting error
- Overflow/underflow error
- Preset error
- System error

There is an error code for each error. These error codes are made up of error code 1 and error code 2.

If an error occurs, the state becomes as follows.

- The corresponding error code is transferred to the error code 1 and 2 variables below.
- The error code is stored in the error list in the Counter Unit.
- Global Error variable below changes to TRUE (1).
- The ERC indicator on the front of the Unit lights up.

Variable names	Type	Name	Function
*_GblErr	BOOL	Global Error	1: Shows that one or more error has occurred. These error codes are stored in the error list in this Unit. 0: Normal
*_ErrCode1	WORD	Error Code 1	Error code 1
*_ErrCode2	WORD	Error Code 2	Error code 2

When the cause of an error is eliminated, the state becomes as follows.

- The error code 1 and 2 variables are cleared.
- Global Error variable goes FALSE (0).
- The ERC indicator on the front of the Unit goes out.

The method for eliminating an error depends on the error type. (The method for eliminating each type of error is given on the pages that follow.)

● Error List File

Up to 30 errors that occurred are recorded in the error list in the Counter Unit in the order they occurred.

If multiple errors occurred at the same time, the error is stored in "_ErrCode1" (error code1) and "_ErrCode2" (error code 2) when the [Read Next Error] variable below is changed from 0 to 1.

When the [Read Next Error] variable changes to TRUE (from 0 to 1) again, the next error can be read out.

When an error is read out after the information of the final error is read out, the value 0 is returned to.

When the [Read Next Error] bit changes to TRUE (from 0 to 1) again, the same error list can be scrolled through.

Variable names	Type	Name	Function
*_RdNxtErr	BOOL	Read Next Error	When multiple errors occurred at the same time, at the rising edge from 0 to 1, the next error is read out from the error list in this Unit.

5-2-1 DM-configuration errors

An allocated DM area setting error is detected during the initialization processing when the Controller is reset or the Unit is restarted.

When an allocated DM area setting error is detected, the error information is stored into memory and the Counter Unit stops operation.

You can read the error information with the Read Next Error variable.

For the allocated DM area offset, refer to *A-1 Differences of NJ Series from CJ Series*.

In the table below, m indicates the first word allocated in DM. $m = D20000 + (N \times 100)$ (N: Unit number)

Error Code 1	Error Code 2		Error	Description
0300	Offset (BCD)		Out of Range	The DM-setting located at $D20000 + (N \times 100) + \text{Offset}$ is Out of Range (N = Machine Number).
0310	Offset (BCD)		Illegal Value	The BCD value of the allocated DM area (m+x (x: offset) words) is invalid. (Any values other than 0 to 9 are invalid.)
0311	Offset (BCD)		Invalid Initial Counter Value	The Initial Counter Value located at $D20000 + (N \times 100) + \text{Offset}$ is outside the counting range that is set for that Counter (N = Machine Number).
0320	Counter No.	Range No. (BCD)	Invalid Range Limits	Upper limit < Lower limit
0330	Counter No.	Range No. (BCD)/ CV No. (BCD)	Invalid Range Limit(s)/ Comparison Value	<p>If the Unit is in Range Mode: Lower and/or Upper Range Limit is/are outside Counting Range. <u>Counter No.</u> indicates the Counter number and <u>Range No.</u> indicates the Range number.</p> <p>If the Unit is in Comparison Mode: Comparison value is outside Counting Range. <u>Counter No.</u> indicates the Counter number and <u>CV No.</u> indicates the Comparison Value number.</p> <p>(The counting range of Circular and Linear Counters can be specified, refer to 3-2-1 <i>Circular Counter</i> and 3-2-2 <i>Linear Counter</i> for more information).</p>
0331	Counter No.	CV No. (BCD)	Duplicate Target Value	For the Counter, with the <u>Counter Number</u> as reported in Error Code 2, one or more Comparison Values are equal. <u>CV No.</u> indicates the Comparison Value number.

● Clearing DM-configuration Errors

DM-configuration errors can be cleared by correcting the faulty settings in device variables for CJ-series Unit (for setting) and consecutively transferring the new configuration data again to the Unit. To transfer the configuration data you can choose from one out of two possibilities:

- Reset the Controller
- Restart the Counter Unit (refer to 4-1-2 *Unit Restart*).

5-2-2 Overflow/Underflow errors

Over- and underflow errors are reported only for Linear Counters assuming that they have been configured to generate error codes (refer to 3-2-2 *Linear Counter*).

Error Code 1	Error Code 2	Error	Description
0450	Counter No.	Overflow	The Linear Counter with the <i>Counter No.</i> as reported in Error Code 2 generated overflow.
0460	Counter No.	Underflow	The Linear Counter with the <i>Counter No.</i> as reported in Error Code 2 generated underflow.

● Clearing overflow/underflow errors

Overflow and underflow errors can be cleared by resetting or presetting the Counter that generated over or underflow. To reset a Counter refer to 3-6 *Reset Signals*.

5-2-3 System Errors

When errors occur in the CPU Unit or on the I/O bus, the ERH-Indicator is turned ON.

At the occurrence of an I/O bus check error, an error code is stored in error codes 1 and 2.

Error Code 1	Error Code 2	Error	Description
000E	0000	I/O Bus Error	An error has occurred on the I/O Bus causing the Counter Unit to be in an undefined state.

● Clearing System errors

Reset the Controller or turn ON the power supply again. If the error persists, then replace the NJ-series CPU Unit.

5-2-4 Preset Error

A Preset error is generated if a Circular or Linear Counter is preset with an invalid Preset Value (refer to 3-4 *Controlling a Counter* for more information about presetting). The Preset Value is invalid if it is outside the counting range of the Circular or Linear Counter.

Error Code 1	Error Code 2	Error	Description
0470	Counter No.	Invalid Preset Value	The Linear Counter with the Counter No. as reported in Error Code 2 is preset with an invalid Preset Value.

● Clearing Preset Error

A Preset error can be cleared by resetting or by presetting the Counter that generated a Preset error, with a valid Preset Value. To reset a Counter refer to *3-6 Reset Signals*. To preset a Counter refer to *3-4 Controlling a Counter*.

5-3 Event Log

5-3-1 Overview of the Event Logs

The Event Log allows the user to access all of the events that occur on the NJ-series Controller including errors and information. You can use the Sysmac Studio or an NS-series PT to confirm current Controller events and the logs of events that have occurred. These logs are called event logs. Controller errors that occur for this Unit are also reported as events in the NJ-series CPU Unit.

Refer to the *NJ-series CPU Unit Software User's Manual* (Cat. No. W501) for details on the event logs in an NJ-series CPU Unit. Refer to the *NJ-series Troubleshooting Manual* (Cat. No. W503) for details on Controller errors, confirmation methods and corrections.

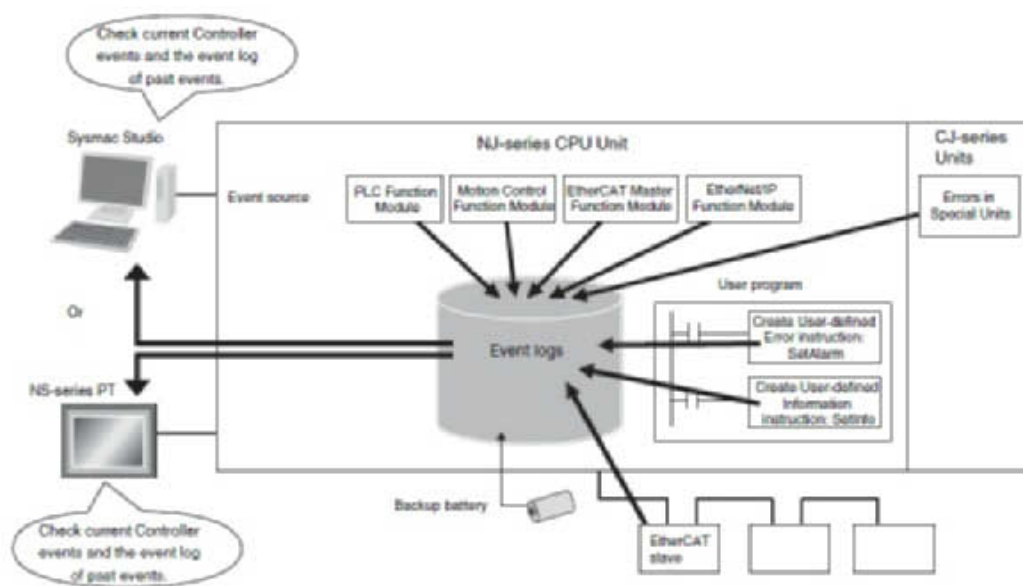

5-3-2 Error Table

The errors that may occur for this Unit are listed below. Event levels are given in the table as follows:

Maj: Major fault level

Prt: Partial fault level

Min: Minor fault level

Obs: Observation

Info: Information

Refer to the *NJ-series Troubleshooting Manual* (Cat. No. W503) for all of the event codes that may occur in an NJ-series Controller.

Event code	Event name	Meaning	Assumed cause	Level				
				Maj	Prt	Min	Obs	Info
68040000 hex	Global Error	One or more errors have occurred	Refer to the Error list for specific details on the cause(s). See 5-2 Error Codes for more information.			X		

5-3-3 Error Descriptions

This section describes the information that is given for individual errors.

Controller Error Descriptions

The items that are used to describe individual errors (events) are described in the following copy of an error table.

Event name	Gives the name of the error.			Event code	Gives the code of the error.	
Meaning	Gives a short description of the error.					
Source	Gives the source of the error.		Source details	Gives details on the source of the error.	Detection timing	Tells when the error is detected.
Error attributes	Level	Tells the level of influence on control.*1	Recovery	Gives the recovery method.*2	Log category	Tells which log the error is saved in.*3
Effects	User program	Tells what will happen to execution of the user program.*4	Operation	Provides special information on the operation that results from the error.		
System-defined variables	Variable	Data type		Name		
	Lists the variable names, data types, and meanings for system-defined variables that provide direct error notification, that are directly affected by the error, or that contain settings that cause the error.					
Cause and correction	Assumed cause		Correction		Prevention	
	Lists the possible causes, corrections, and preventive measures for the error.					
Attached information	This is the attached information that is displayed by the Sysmac Studio or an NS-series PT.					
Precautions/Remarks	Provides precautions, restrictions, and supplemental information.					

*1 One of the following:

Major fault: Major fault level
 Partial fault: Partial fault level
 Minor fault: Minor fault level
 Observation
 Information

*2 One of the following:

Automatic recovery: Normal status is restored automatically when the cause of the error is removed.
 Error reset: Normal status is restored when the error is reset after the cause of the error is removed.
 Cycle the power supply: Normal status is restored when the power supply to the Controller is turned OFF and then back ON after the cause of the error is removed.
 Controller reset: Normal status is restored when the Controller is reset after the cause of the error is removed.
 Depends on cause: The recovery method depends on the cause of the error.

*3 One of the following:

System: System event log
 Access: Access event log

*4 One of the following:

Continues: Execution of the user program will continue.
 Stops: Execution of the user program stops.
 Starts: Execution of the user program starts.

Error Descriptions

Event name	Global Error		Event code	68040000 hex		
Meaning	One or more error has occurred. Errors codes are stored in the error list.					
Source	Function Module		Source details	CJ-series Unit	Detection timing	Depends on the nature of the error.
Error attributes	Level	Minor	Recovery	Depends on the cause.	Log category	System
Effects	User program	Continues	Operation	Depends on the nature of the error. Check error information in the operation manual of the Counter Unit.		
System-defined variables	Variable		Data type		Name	
	*_GlbErr		BOOL		Global Error	
Cause and correction	Assumed cause		Correction		Prevention	
	DM Configuration Error		Check the attached information with the Sysmac Studio or check error codes 1 and 2 in the error history of the Counter Unit. Perform corrective actions for system recovery following the descriptions for error codes given in the manual of the Counter Unit.		Depends on the nature of the error. Check the error information in the operation manual of the Counter Unit and perform the required corrective actions.	
	Overflow/Underflow Error					
	System Error					
Preset Error						
Attached information	Error code 1 Error code 2					
Precautions/Remarks	None					

5-4 Maintenance and Inspection

This section describes the routine cleaning and inspection recommended as regular maintenance.

5-4-1 Cleaning

Clean the Counter Unit regularly as described below in order to keep it in its optimal operating condition.

- Wipe the Unit with a dry, soft cloth for regular cleaning.
- When a spot cannot be removed with a dry cloth, dampen the cloth with a neutral cleanser, wring out the cloth, and wipe the Unit.
- A smudge may remain on the Unit from gum, vinyl, or tape that was left on for a long time. Remove the smudge when cleaning.



Precautions for Correct Use

Never use volatile solvents such as paint thinner or benzene or chemical wipes. These substances could damage the surface of the Unit.

5-4-2 Routine Inspections

In order for your Counter Unit to continue operating at optimum condition, periodic inspections are necessary. Be sure to inspect the system periodically to keep it in its optimal operating condition. In general, inspect the system once every 6 to 12 months, but inspect more frequently if the system is used with high temperature or humidity or under dirty/dusty conditions.

● **Inspection Equipment**

Prepare the following equipment before inspecting the system.

Required Equipment:

Have a standard and Phillips-head screwdriver, multimeter, alcohol, and a clean cloth.

Equipment that could be needed:

Depending on the system conditions, a synchroscope, oscilloscope, thermometer, gas sensor or hygrometer (to measure humidity) might be needed.

● Inspection Procedure

Check the items in the following table and correct any items that are not according to the criteria.

Item		Criteria	Equipment
Environmental conditions	Ambient temperature	0°C to 55°C	Thermometer
	Ambient humidity	10% to 90%	Hygrometer
	Dust/dirt accumulation	None	---
	Is the Unit exposed to any spray of water, oil, or chemicals?	None	---
	Is the Unit exposed to corrosive or flammable gases?	None	Gas sensor
	Is the Unit exposed to shock or vibration?	None	
Installation	Is the Unit installed securely?	No looseness	---
	Are the external connectors securely mounted?	No looseness	---
	Is all external wiring securely connected?	No looseness	---
	Are the external connectors fully inserted?	No looseness	---
	Are the connecting cables undamaged?	No damage	---



Appendix

A-1 Differences of NJ Series from CJ Series	A-2
A-1-1 Functional Difference	A-2
A-1-2 Differences in Access Methods from a User Program	A-3
A-2 Using Terminal Block Units with Screw-terminals	A-14
A-3 Application Restrictions	A-16

A-1 Differences of NJ Series from CJ Series

You can use the CJ1W-CTL41-E 4-Channel Counter Unit with the NJ-series Units.

If this Unit is used with the NJ Series, some functions become unavailable compared to when it is used with the CJ Series.

The following shows differences between the NJ Series and the CJ-series for each function of this Unit.

A-1-1 Functional Difference

Item	Function in CJ series	Function in NJ series
Number of Counters	4	Same as on the left.
Counter Type	<ul style="list-style-type: none"> • Circular Counters • Linear Counters 	Same as on the left.
Maximum Input Frequency	100 kHz	Same as on the left.
Input Signal	A phase, B phase, Z phase	Same as on the left.
Types of Inputs	<ul style="list-style-type: none"> • Phase difference pulse input 1, 2, 4x • Addition/subtraction pulse input • Pulse + direction input 	Same as on the left.
Control of Counters using allocation area (CIO)	<ul style="list-style-type: none"> • Open gate (Counter start) • Close gate (Counter stop) • Counter presets • Counter resets • Counter value capture 	Counter value capture cannot be used.
External Control Input Function	<ul style="list-style-type: none"> • Gate function • Reset function • Preset function • Capture function • Stop/capture/continue functions • Stop/capture/reset/continue functions • Capture/reset functions • Reset enable function • Reset disable function 	The capture, Stop/capture/continue, Stop/capture/reset/continue, and Capture/reset functions cannot be used.
Output Control Mode	Automatic ON/OFF output according to the following two modes <ul style="list-style-type: none"> • Range Mode • Comparison Mode 	Same as on the left.
Counter Reset Conditions	<ul style="list-style-type: none"> • Counter reset bit • Z signal 	Same as on the left.
Other Functions	<ul style="list-style-type: none"> • Hysteresis 	Same as on the left.
Noise Filter	<ul style="list-style-type: none"> • Fixed Noise Filter 100 kHz 	Same as on the left.
Counter Initial Values	<ul style="list-style-type: none"> • Counter initial values 	Same as at the left. However, because the NJ Series has no power OFF interrupt task, operation cannot be restarted from the position at which the power was interrupted.

Item	Function in CJ series	Function in NJ series
IORD Instruction, IOWR Instruction	You can read or write the following data. <ul style="list-style-type: none"> Allocated DM data Range data and comparison data Captured Counter Value Pulse rate history log file data Counter value Counter Unit set and reset Error clear 	The IORD/IOWR instruction cannot be used. Therefore, you cannot read or write the data on the left.
Starting of External Interrupt Task by Output	You can use external output and internal output unit output patterns to start CJ1-H/CJ1M CPU Unit external interrupt tasks.	Cannot use.
Error History Log Functions	Up to 30	Same as on the left.

A-1-2 Differences in Access Methods from a User Program

With the NJ Series, device variables for CJ-series Unit are used for the Counter Unit functions.

The following tables show how the words and bits of CJ-series I/O memory or the NJ-series memory used for CJ-series Unit correspond to the NJ-series device variables for CJ-series Unit.

Start address of special I/O Unit area: $n = 2000 \text{ words} + \text{Unit number} \times 10$ (Unit number: 0 to 92)

Start address of the special I/O Unit DM area: $m = D20000 + \text{Unit number} \times 100$ (Unit number: 0 to 92)

Switch Settings	Unit Number	CIO Area words allocated to Special I/O Unit	DM Area words allocated to Special I/O Unit
0	#0	CIO 2000 to CIO 2039	D20000 to D20399
1	#1	CIO 2010 to CIO 2049	D20100 to D20499
2	#2	CIO 2020 to CIO 2059	D20200 to D20599
3	#3	CIO 2030 to CIO 2069	D20300 to D20699
4	#4	CIO 2040 to CIO 2079	D20400 to D20799
5	#5	CIO 2050 to CIO 2089	D20500 to D20899
6	#6	CIO 2060 to CIO 2099	D20600 to D20999
7	#7	CIO 2070 to CIO 2109	D20700 to D21009
8	#8	CIO 2080 to CIO 2119	D20800 to D21199
9	#9	CIO 2090 to CIO 2129	D20900 to D21299
10	#10	CIO 2100 to CIO 2139	D21000 to D21399
...
n	#n	CIO 2000 + (n * 10) to CIO 2000 + (n * 10) + 39	D 20000 + (n * 100) to D 20000 + (n * 100) + 399
...
92	#92	CIO 2920 to CIO 2959	D29200 to D 29599
93	Cannot be set	Not Applicable	Not Applicable
94			
95			



Additional Information

- If two or more Special I/O Units are set to an identical Unit number or if one Special I/O Unit is set to areas of plural Unit numbers, the CPU Unit has a major fault level error, a duplicated Unit number error, and stops operation.

- After correcting the Unit number setting, cycle the power to the Controller.
- One Counter Unit occupies allocation areas of four Unit numbers. Be sure that no Unit numbers are duplicated.
To avoid duplication, when you set a High-speed Counter Unit to the Unit number "n", set the next Special I/O Unit to the Unit number "n + 4".

Special I/O Units Area (Allocated CIO Area words)

● Allocated CIO Area words for outputs

CJ-series I/O memory address		NJ-series device variables for CJ-series Unit	
Word	Bit	Variable name	Description
General			
n	00		Read Next Error
	01 to 15	Undefined	---
Counter 1			
n+1	00	*_Ch1_Enbl	Open Gate
	01	*_Ch1_Dsbl	Close Gate
	02	*_Ch1_Prst	Preset
	03	*_Ch1_Rst	Reset
	04	Undefined	Capture
	05	*_Ch1_RstEnbl	Reset Enable
	06 to 15	Undefined	---
n+2, n+3	00 to 15	*_Ch1_PrstLinCtVal (Linear Counter)	Preset Value
		*_Ch1_PrstRingCtVal (Circular Counter)	
Counter 2			
n+4	00	*_Ch2_Enbl	Open Gate
	01	*_Ch2_Dsbl	Close Gate
	02	*_Ch2_Prst	Preset
	03	*_Ch2_Rst	Reset
	04	Undefined	Capture
	05	*_Ch2_RstEnbl	Reset Enable
	06 to 15	Undefined	---
n+5, n+6	00 to 15	*_Ch2_PrstLinCtVal (Linear Counter)	Preset Value
		*_Ch2_PrstRingCtVal (Circular Counter)	
Counter 3			
n+7	00	*_Ch2_Enbl	Open Gate
	01	*_Ch2_Dsbl	Close Gate
	02	*_Ch2_Prst	Preset
	03	*_Ch2_Rst	Reset
	04	Undefined	Capture
	05	*_Ch2_RstEnbl	Reset Enable
	06 to 15	Undefined	---
n+8, n+9	00 to 15	*_Ch2_PrstLinCtVal (Linear Counter)	Preset Value
		*_Ch2_PrstRingCtVal (Circular Counter)	
Counter 4			

CJ-series I/O memory address		NJ-series device variables for CJ-series Unit	
Word	Bit	Variable name	Description
General			
n+10	00	*_Ch2_Enbl	Open Gate
	01	*_Ch2_Dsbl	Close Gate
	02	*_Ch2_Prst	Preset
	03	*_Ch2_Rst	Reset
	04	Undefined	Capture
	05	*_Ch2_RstEnbl	Reset Enable
	06 to 15	Undefined	---
n+11, n+12	00 to 15	*_Ch2_PrstLinCtVal (Linear Counter)	Preset Value
		*_Ch2_PrstRingCtVal (Circular Counter)	

● Allocated CIO Area words for inputs

CJ-series I/O memory address		NJ-series device variables for CJ-series Unit	
Word	Bit	Variable name	Description
General			
n+13, n+14	00 to 15	*_OutStaDat	Output Status • 32 outputs status (correspond to n+13, n+14)
n+13	00	*_OutSta0	Digital Output 00 Status
	01	*_OutSta1	Digital Output 01 Status
	02	*_OutSta2	Soft Output 2 Status
	:	:	:
	15	*_OutSta15	Soft Output 15 Status
n+14	00	*_OutSta16	Soft Output 16 Status
	:	:	:
	15	*_OutSta31	Soft Output 31 Status
n+15	00 to 15	*_ErrCode1	Error Code 1
n+16	00 to 15	*_ErrCode2	Error Code 2
n+17	00	*_GlbErr	Global Error
	01	Undefined	External Interrupt Task Start Standby Status
	02	*_UnitInItSta	Data Transfer Busy • Unit initialization processing underway
	03	Undefined	Data Transfer Complete
	04	*_IABlkOverlapSta	IA Blocks overlap
	05 to 15	Undefined	---
	Counter 1		
n+18	00 to 07	*_Ch1RngCmpDatSta	Range/Comparison Value active • 8 outputs status (correspond to bits 00 to 07)
n+18	00	*_Ch1_RngCmpSta0	Range 0/Comparison 0 Value active
	:	:	:
	03	*_Ch1_RngCmpSta3	Range 3/Comparison 3 Value active
	04	*_Ch1_RngCmpSta4	Comparison 4 Value active
	:	:	:
	07	*_Ch1_RngCmpSta7	Comparison 7 Value active
n+19, n+20	00 to 15	*_Ch1_LinCtVal (Linear Counter)	Counter Value
		*_Ch1_RingCtVal (Circular Counter)	

CJ-series I/O memory address		NJ-series device variables for CJ-series Unit	
Word	Bit	Variable name	Description
n+21	00	*_Ch1_CtOvf	Counter Overflow
	01	*_Ch1_CtUdf	Counter Underflow
	02	*_Ch1_CtRun	Counter Running/Gate Open
	03	*_Ch1_CntDir	Counter Direction
	04	*_Ch1_PrstSta	Preset Activated
	05	*_Ch1_RstSta	Reset Activated
	06	Undefined	Capture Activated
	07	*_Ch1_ZSig	Z-signal Activated
	08 to 15	Undefined	---
Counter 2			
n+22	00 to 07	*_Ch2RngCmpDatSta	Range/Comparison Value active • 8 outputs status (correspond to bits 00 to 07)
n+22	00	*_Ch2_RngCmpSta0	Range 0/Comparison 0 Value active
	:	:	:
	03	*_Ch2_RngCmpSta3	Range 3/Comparison 3 Value active
	04	*_Ch2_RngCmpSta4	Comparison 4 Value active
	:	:	:
	07	*_Ch2_RngCmpSta7	Comparison 7 Value active
n+23, n+24	00 to 15	*_Ch2_LinCtVal (Linear Counter) *_Ch2_RingCtVal (Circular Counter)	Counter Value
n+25	00	*_Ch2_CtOvf	Counter Overflow
	01	*_Ch2_CtUdf	Counter Underflow
	02	*_Ch2_CtRun	Counter Running/Gate Open
	03	*_Ch2_CntDir	Counter Direction
	04	*_Ch2_PrstSta	Preset Activated
	05	*_Ch2_RstSta	Reset Activated
	06	Undefined	Capture Activated
	07	*_Ch2_ZSig	Z-signal Activated
	08 to 15	Undefined	---
Counter 3			
n+26	00 to 07	*_Ch3RngCmpDatSta	Range/Comparison Value active • 8 outputs status (correspond to bits 00 to 07)

CJ-series I/O memory address		NJ-series device variables for CJ-series Unit	
Word	Bit	Variable name	Description
n+26	00	*_Ch3_RngCmpSta0	Range 0/Comparison 0 Value active
		:	:
	03	*_Ch3_RngCmpSta3	Range 3/Comparison 3 Value active
	04	*_Ch3_RngCmpSta4	Comparison 4 Value active
		:	:
	07	*_Ch3_RngCmpSta7	Comparison 7 Value active
n+27, n+28	00 to 15	*_Ch3_LinCtVal (Linear Counter)	Counter Value
		*_Ch3_RingCtVal (Circular Counter)	
n+29	00	*_Ch3_CtOvf	Counter Overflow
	01	*_Ch3_CtUdf	Counter Underflow
	02	*_Ch3_CtRun	Counter Running/Gate Open
	03	*_Ch3_CntDir	Counter Direction
	04	*_Ch3_PrstSta	Preset Activated
	05	*_Ch3_RstSta	Reset Activated
	06	Undefined	Capture Activated
	07	*_Ch3_ZSig	Z-signal Activated
	08 to 15	Undefined	---
Counter 4			
n+30	00 to 07	*_Ch4RngCmpDatSta	Range/Comparison Value active • 8 outputs status (correspond to bits 00 to 07)
n+30	00	*_Ch4_RngCmpSta0	Range 0/Comparison 0 Value active
		:	:
	03	*_Ch4_RngCmpSta3	Range 3/Comparison 3 Value active
	04	*_Ch4_RngCmpSta4	Comparison 4 Value active
		:	:
	07	*_Ch4_RngCmpSta7	Comparison 7 Value active
n+31, n+32	00 to 15	*_Ch4_LinCtVal (Linear Counter)	Counter Value
		*_Ch4_RingCtVal (Circular Counter)	

CJ-series I/O memory address		NJ-series device variables for CJ-series Unit	
Word	Bit	Variable name	Description
n+33	00	*_Ch4_CtOvf	Counter Overflow
	01	*_Ch4_CtUdf	Counter Underflow
	02	*_Ch4_CtRun	Counter Running/Gate Open
	03	*_Ch4_CntDir	Counter Direction
	04	*_Ch4_PrstSta	Preset Activated
	05	*_Ch4_RstSta	Reset Activated
	06	Undefined	Capture Activated
	07	*_Ch4_ZSig	Z-signal Activated
	08 to 15	Undefined	---
n+34 to n+39	00 to 15	Undefined	---

Special I/O Unit DM Area (Allocated DM Area words)

CJ-series I/O memory address		NJ-series device variables for CJ-series Unit	
Word	Bit	Variable name	Description
General			
m	00 to 07	*_OutCtlMdCfg	Output Control Mode
	08 to 15		Counter Output Pattern AND/OR Selection <ul style="list-style-type: none"> • Bits 00 to 07: Output Control Mode • Bits 08 to 15: Counter output pattern AND/OR selection
m+1	00 to 15	Undefined	External Interrupt Task No. Offset (Output)
m+2, m+3	00 to 15	Undefined	External Interrupt Task Enable Data (Output)
m+4 to m+9	00 to 15	Undefined	Undefined
Counter 1			
m+10	00 to 15	*_Ch1_CtTypCfg	Counter Type
m+11	00 to 03	*_Ch1_SigTypCfg	Signal Type
	04 to 15		---
m+12	00 to 03	*_Ch1_ZOvfUdfCfg	Z-reset Mode
	04 to 07		Overflow/Underflow error-code generation <ul style="list-style-type: none"> • Bits 00 to 03: Reset by Z phase • Bits 04 to 07: Overflow/underflow error setting
	08 to 15		---
m+13, m+14	00 to 15	*_Ch1_UpCtLmtCfg	Upper Count Limit Circular/Linear

CJ-series I/O memory address		NJ-series device variables for CJ-series Unit	
Word	Bit	Variable name	Description
m+15, m+16	00 to 15	*_Ch1_LowCtLmtCfg	Lower Count Limit Linear
m+17, m+18	00 to 15	*_Ch1_InitLinCtCfg, *_Ch1_InitRingCtCfg	Initial Count Value
m+19, m+20	00 to 15	*_Ch1_RngCmpEnblCfg	Range/Comparison Enable Data
m+21, m+22	00 to 15	*_Ch1_OutSetPatCfg	Output Set Pattern
m+23, m+24	00 to 15	*_Ch1_OutRstPatCfg	Output Reset Pattern
m+25	00 to 15	*_Ch1_HystrsCfg	Hysteresis
m+26	00 to 07	*_Ch1_NumRngCmpCfg	Number of Ranges/Comparison Values
	08 to 15	Undefined	---
m+27	00 to 03	*_Ch1_MemAreaCfg	Memory Area
	04 to 15	Undefined	---
m+28, m+29	00 to 15	*_Ch1_MemAdrCfg	Memory Address
Counter 2			
m+30	00 to 15	*_Ch2_CtTypCfg	Counter Type
m+31	00 to 03	*_Ch2_SigTypCfg	Signal Type
	04 to 15		---
m+32	00 to 03	*_Ch2_ZOVfUdfCfg	Z-reset Mode
	04 to 07		Overflow/Underflow error-code generation <ul style="list-style-type: none"> • Bits 00 to 03: Reset by Z phase • Bits 04 to 07: Overflow/underflow error setting
	08 to 15		---
m+33, m+34	00 to 15	*_Ch2_UpCtLmtCfg	Upper Count Limit Circular/Linear
m+35, m+36	00 to 15	*_Ch2_LowCtLmtCfg	Lower Count Limit Linear
m+37, m+38	00 to 15	*_Ch2_InitLinCtCfg, *_Ch2_InitRingCtCfg	Initial Count Value
m+39, m+40	00 to 15	*_Ch2_RngCmpEnblCfg	Range/Comparison Enable Data
m+41, m+42	00 to 15	*_Ch2_OutSetPatCfg	Output Set Pattern
m+43, m+44	00 to 15	*_Ch2_OutRstPatCfg	Output Reset Pattern
m+45	00 to 15	*_Ch2_HystrsCfg	Hysteresis
m+46	00 to 07	*_Ch2_NumRngCmpCfg	Number of Ranges/Comparison Values
	08 to 15	Undefined	---
m+47	00 to 03	*_Ch2_MemAreaCfg	Memory Area
	04 to 15	Undefined	---

CJ-series I/O memory address		NJ-series device variables for CJ-series Unit	
Word	Bit	Variable name	Description
m+48, m+49	00 to 15	*_Ch2_MemAdrCfg	Memory Address
Counter 3			
m+50	00 to 15	*_Ch3_CtTypCfg	Counter Type
m+51	00 to 03	*_Ch3_SigTypCfg	Signal Type
	04 to 15		---
m+52	00 to 03	*_Ch3_ZOvfUdfCfg	Z-reset Mode
	04 to 07		Overflow/Underflow error-code generation <ul style="list-style-type: none"> • Bits 00 to 03: Reset by Z phase • Bits 04 to 07: Overflow/underflow error setting
	08 to 15		---
m+53, m+54	00 to 15	*_Ch3_UpCtLmtCfg	Upper Count Limit Circular/Linear
m+55, m+56	00 to 15	*_Ch3_LowCtLmtCfg	Lower Count Limit Linear
m+57, m+58	00 to 15	*_Ch3_InitLinCtCfg, *_Ch1_InitRingCtCfg	Initial Count Value
m+59, m+60	00 to 15	*_Ch3_RngCmpEnblCfg	Range/Comparison Enable Data
m+61, m+62	00 to 15	*_Ch3_OutSetPatCfg	Output Set Pattern
m+63, m+64	00 to 15	*_Ch3_OutRstPatCfg	Output Reset Pattern
m+65	00 to 15	*_Ch3_HystrsCfg	Hysteresis
m+66	00 to 07	*_Ch3_NumRngCmpCfg	Number of Ranges/Comparison Values
	08 to 15	Undefined	---
m+67	00 to 03	*_Ch3_MemAreaCfg	Memory Area
	04 to 15	Undefined	---
m+68, m+69	00 to 15	*_Ch3_MemAdrCfg	Memory Address
Counter 4			
m+70	00 to 15	*_Ch4_CtTypCfg	Counter Type
m+71	00 to 03	*_Ch4_SigTypCfg	Signal Type
	04 to 15		---
m+72	00 to 03	*_Ch4_ZOvfUdfCfg	Z-reset Mode
	04 to 07		Overflow/Underflow error-code generation <ul style="list-style-type: none"> • Bits 00 to 03: Reset by Z phase • Bits 04 to 07: Overflow/underflow error setting
	08 to 15		---
m+73, m+74	00 to 15	*_Ch4_UpCtLmtCfg	Upper Count Limit Circular/Linear

CJ-series I/O memory address		NJ-series device variables for CJ-series Unit	
Word	Bit	Variable name	Description
m+75, m+76	00 to 15	*_Ch4_LowCtLmtCfg	Lower Count Limit Linear
m+77, m+78	00 to 15	*_Ch4_InitLinCtCfg, *_Ch1_InitRingCtCfg	Initial Count Value
m+79, m+80	00 to 15	*_Ch4_RngCmpEnblCfg	Range/Comparison Enable Data
m+81, m+82	00 to 15	*_Ch4_OutSetPatCfg	Output Set Pattern
m+83, m+84	00 to 15	*_Ch4_OutRstPatCfg	Output Reset Pattern
m+85	00 to 15	*_Ch4_HystrsCfg	Hysteresis
m+86	00 to 07	*_Ch4_NumRngCmpCfg	Number of Ranges/Comparison Values
	08 to 15	Undefined	---
m+87	00 to 03	*_Ch4_MemAreaCfg	Memory Area
	04 to 15	Undefined	---
m+88, m+89	00 to 15	*_Ch4_MemAdrCfg	Memory Address

Range Data

Range data is set in the user-defined variable.

Two types of structure data are prepared beforehand for range data user-defined variables: one type for Linear Counters and one type for Circular Counters.

Use these structures to define user-defined variables.

Data type (name)	Member	Data type	Name
_sCJCTL41_Ex_RngLin	LowLmt	DINT	Lower Limit Range 0
	UpLmt	DINT	Upper Limit Range 0
	OutPat	DWORD	Output Pattern Range 0
_sCJCTL41_Ex_RngRing	LowLmt	UDINT	Lower Limit Range 0
	UpLmt	UDINT	Upper Limit Range 0
	OutPat	DWORD	Output Pattern Range 0

The table below is an example in which 4 Linear Counter range structure data type (_sCJCTL41_Ex_RngLin) are used as user-defined variables and the variable name is defined as "aaaa".

k is set with device variables for CJ-series Unit *_Ch#_MemAreaCfg and *_Ch#_MemAdrCfg.

CJ-series I/O memory address		NJ-series device variables for CJ-series Unit	
Word	Bit	Variable name	Description
k to k+5		aaaa[0]	Range 0
k, k+1	00 to 15	aaaa[0].LowLmt	Lower Limit Range 0
k+2, k+3	00 to 15	aaaa[0].UpLmt	Upper Limit Range 0
k+4, k+5	00 to 15	aaaa[0].OutPat	Output Pattern Range 0

CJ-series I/O memory address		NJ-series device variables for CJ-series Unit	
Word	Bit	Variable name	Description
k+6 to k+11	00 to 15	aaaa[1]	Range 1
k+12 to k+17	00 to 15	aaaa[2]	Range 2
k+18 to k+23	00 to 15	aaaa[3]	Range 3

Comparison Data

Comparison data is set in the user-defined variable.

Two types of structure data are prepared beforehand for comparison data user-defined variables: one type for Linear Counters and one type for Circular Counters.

Use these structures to define user-defined variables.

Data type (name)	Member	Data type	Name
_sCJCTL41_Ex_CmpLin	CmpVal	DINT	Comparison Value
	AddSetPat	DWORD	+Set Pattern
	AddRstPat	DWORD	+Reset Pattern
	SubSetPat	DWORD	–Set Pattern
	SubRstPat	DWORD	–Reset Pattern
_sCJCTL41_Ex_CmpRing	CmpVal	UDINT	Comparison Value
	AddSetPat	DWORD	+Set Pattern
	AddRstPat	DWORD	+Reset Pattern
	SubSetPat	DWORD	–Set Pattern
	SubRstPat	DWORD	–Reset Pattern

The table below is an example in which 8 Circular Counter comparison structure data type (_sCJCTL41_Ex_CmpRing) are used as user-defined variables and the variable name is defined as "bbbb".

k is set with device variables for CJ-series Unit *_Ch#_MemAreaCfg and *_Ch#_MemAdrCfg.

CJ-series I/O memory address		NJ-series device variables for CJ-series Unit	
Word	Bit	Variable name	Description
k to k+9		bbbb[0]	Comparison data 0
k, k+1	00 to 15	bbbb[0].CmpVal	Comparison data 0 Comparison Value
k+2, k+3	00 to 15	bbbb[0].AddSetPat	Comparison data 0 +Set Pattern
k+4, k+5	00 to 15	bbbb[0].AddRstPat	Comparison data 0 +Reset Pattern
k+6, k+7	00 to 15	bbbb[0].SubSetPat	Comparison data 0 –Set Pattern
k+8, k+9	00 to 15	bbbb[0].SubRstPat	Comparison data 0 –Reset Pattern
k+10 to k+19	00 to 15	bbbb[1]	Comparison data 1
k+20 to k+29	00 to 15	bbbb[2]	Comparison data 2
k+30 to k+39	00 to 15	bbbb[3]	Comparison data 3
k+40 to k+49	00 to 15	bbbb[4]	Comparison data 4
k+50 to k+59	00 to 15	bbbb[5]	Comparison data 5
k+60 to k+69	00 to 15	bbbb[6]	Comparison data 6
k+70 to k+79	00 to 15	bbbb[7]	Comparison data 7

A-2 Using Terminal Block Units with Screw-terminals

This section describes the signal layout of the screw terminals on the Connector Terminal Converter Unit (XW2B-40G4, XW2B-40G5, XW2G-40G7-E, or XW2D-40G6). The Unit is used to connect external signals such as power supply signals, digital I/O signals, and Counter input signals to a CJ1W-CTL41-E Counter Unit.

Item		XW2G-40G7-E		XW2B-40G4/XW2B-40G5		XW2D-40G6	
		Signal	Pin No.	Signal	Pin No.	Signal	Pin No.
Counter 1	A	LD+/24V+	1A+	LD+	1	LD+	A1
		LD-/24V-	1A-	LD-	2	LD-	B1
	B	LD+/24V+	1B+	LD+	3	LD+	A2
		LD-/24V-	1B-	LD-	4	LD-	B2
	Z	LD+/24V+	1Z+	LD+	5	LD+	A3
		LD-/24V-	1Z-	LD-	6	LD-	B3
Spare		Not connected		Not connected	7 to 10	Not connected	A4, B4, A5, B5
Counter 2	A	LD+/24V+	2A+	LD+	11	LD+	A6
		LD-/24V-	2A-	LD-	12	LD-	B6
	B	LD+/24V+	2B+	LD+	13	LD+	A7
		LD-/24V-	2B-	LD-	14	LD-	B7
	Z	LD+/24V+	2Z+	LD+	15	LD+	A8
		LD-/24V-	2Z-	LD-	16	LD-	B8
Spare		Not connected		Not connected	17 to 20	Not connected	A9, B9, A10, B10
Counter 3	A	LD+/24V+	3A+	LD+	21	LD+	A11
		LD-/24V-	3A-	LD-	22	LD-	B11
	B	LD+/24V+	3B+	LD+	23	LD+	A12
		LD-/24V-	3B-	LD-	24	LD-	B12
	Z	LD+/24V+	3Z+	LD+	25	LD+	A13
		LD-/24V-	3Z-	LD-	26	LD-	B13
Spare		Not connected		Not connected	27 to 30	Not connected	A14, B14, A15, B15
Counter 4	A	LD+/24V+	4A+	LD+	31	LD+	A16
		LD-/24V-	4A-	LD-	32	LD-	B16
	B	LD+/24V+	4B+	LD+	33	LD+	A17
		LD-/24V-	4B-	LD-	34	LD-	B17
	Z	LD+/24V+	4Z+	LD+	35	LD+	A18
		LD-/24V-	4Z-	LD-	36	LD-	B18
Spare		Not connected		Not connected	37 to 40	Not connected	A19, B19, A20, B20

● Connections

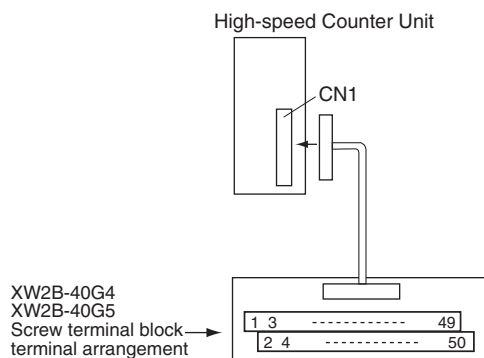

Additional Information

The top row of the Terminal Block Unit (numbered 1 to 39) corresponds to the pins numbered A1 to A20 of the associated connector (CN1) on the Counter Unit. The bottom row of the Terminal Block Unit (numbered 2 to 40) corresponds to the pins numbered B1 to B20 of the associated connector (CN1) on the Unit.

A-3 Application Restrictions

The following restrictions apply when using CJ1W-CTL41-E 4-Channel Counter Units.

Restriction	Reference
<p>The Open Gate, Close Gate, Preset Counter or Reset in device variables for CJ-series Unit (for output) may not be executed if the CPU Unit is ON for only one task period. Always keep them turned ON until the status changes in the corresponding bit.</p>	<p><i>4-2 Memory Allocation</i></p>
<p>The comparison operation stops for 1.5 ms from when the High-speed Counter Value falls within the Upper Range Limit or Lower Range Limit for the range data. However, the comparison does not stop for other Counters.</p> <p>Consider the time that the comparison is stopped when making settings for range data.</p>	<p><i>3-5-1 Range Mode</i></p>
<p>When the High-speed Counter Value reaches the comparison value, comparison stops for 1.5 ms. However, comparison for other Counters does not stop.</p> <p>Consider the time the comparison stops when setting Comparison Data.</p>	<p><i>3-5-2 Comparison Mode</i></p>
<p>I/O is not refreshed during unit initialization processing (while "*_UnitInitSta" is TRUE). Note that Counter Values are not updated during this time.</p>	<p><i>4-1-1 Data Flow</i></p>
<p>At a restart or when the Controller is reset, including when the power is turned ON, the variable *_UnitInitSta (unit initialization being processed) is TRUE for about 120 ms.</p>	<p><i>4-2-3 Details of Device Variables for CJ-series Unit (for input/output)</i></p>

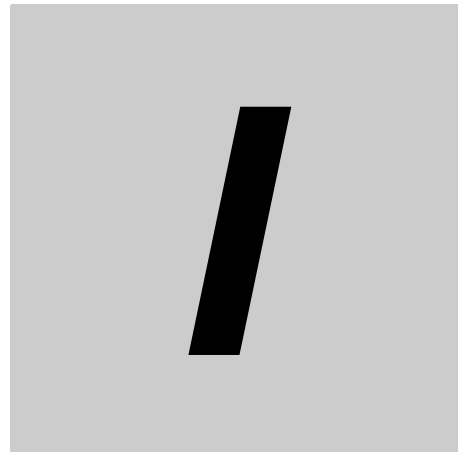

Index

Index

Symbols

+CV crossing	3-21
+Reset Pattern	3-23
+Set Pattern	3-23

A

Allocated CIO Area Words	A-4
Allocated CIO Area words for inputs	A-6
Allocated DM Area	A-9
Application Restrictions	A-16

C

Cable	2-8
Circular Counter	3-4
Clearing DM-configuration Errors	5-5
Comparison Data	A-13
Comparison Mode	3-13, 3-20
Comparison Value	3-13
Connector Pin Layout	2-7
Controller Errors	5-7
Counter Input Configuration	2-10
Counter Inputs	2-7
Counter Output Patterns	3-3
Counter Overflow	3-6, 3-7, 4-12
Counter Type	1-2, 3-4
Counter Underflow	3-6, 3-7, 4-12
Counter Value	3-4, 4-15
Counting Direction	3-12, 4-16
-CV crossing	3-21

D

Device Name	4-5
Device Variable for CJ-series Unit	4-3
Digital Input	2-10
Disable Comparison Values	3-25
DM-configuration errors	5-4
Duplicate Unit Number	2-3

E

Enable Comparison Values	3-25
Encoder	2-11
Error Code	4-14
Error Codes	5-3
Error Indicators	5-2
Error List File	5-3
Event Code	5-7
Event Levels	5-7
Event Log	5-7
Event Name	5-7

G

Gate	3-11
General Specifications	1-6
Global Error	4-14, 5-3, 5-9

H

Hysteresis	1-3, 3-29, 4-18
------------	-----------------

I

I/O Bus Error	5-5
I/O Map	4-5
I/O Port	4-5
IA Blocks Overlap	4-8, 4-14
Indirect Address Specification	4-8
Indirect Addresses	1-11
Indirect Addressing	4-9
Initial Count Value	4-18
Initial Counter Value	3-30
Input Signal Type	1-2, 3-8
Input Specifications	1-7
Input Type	1-11

L

Line Driver	2-7
Linear Counter	3-5
Linear Lower Count Limit	3-6
Logically AND/OR Counter Output Patterns	3-19
Lower Count Limit	3-6
Lower Count Limit Linear	4-17
Lower Limit Range	3-17
Lower Range Limit	3-16

M

Machine Number Switch	2-3
Memory Address	4-9, 4-10, 4-11, 4-18
Memory Allocation	4-7
Memory Allocation for Comparison Data	4-20
Memory Allocation for Ranges	4-19
Memory Area	4-9, 4-10, 4-11, 4-18

N

Noise Filtering	1-3
Number of Ranges/Comparison Values	4-9, 4-18

O

Operating Procedure	1-12
Output Control Mode	1-2, 1-11, 4-17, A-9
Output Driver	2-10
Output Mode	1-11
Output Status	3-13, 3-14
Overflow Error	5-5

P

Phase Differential	3-8
Preset	3-11, 4-13
Preset Activated	4-16, A-7
Preset Error	5-3, 5-5
Proximity Switch	1-4
Pulse & Direction	3-9

R

Range Data	A-12
Range Mode	3-13, 3-14
Range/Comparison Enable Data	3-19, 3-25, 4-18, A-10
Range/Comparison Values active	3-18
Reset	3-12, 3-27
Reset Activated	4-16
Reset Enable Bit	3-27
Reset Enable Source	3-27
-Reset Pattern	3-23
Reset Source	3-27
Resetting Counter Value	1-3
Routine Inspections	5-10

S

-Set Pattern	3-23
Soft Output	3-13, 4-14, A-6
Software Reset Bit	3-27
Special Unit Settings	4-16
Specifications	1-6
Specifying Range Data	3-16
Structure Data Type	1-13
Structure Data Types	4-6
Sysmac Studio	1-3, 1-12
System Errors	5-5
System-defined Variable	4-2

T

Terminal Block Unit	A-14
Terminal Bock Unit	2-8

U

Underflow Error	5-5
Unit Busy	4-14
Unit Configuration	3-2
Unit Error	5-2
Unit Output Pattern	3-13
Unit Restart	4-4
Up & Down Pulse	3-9
Updating Unit Output Pattern	3-26
Upper Count Limit	3-5, 3-6, 4-17
Upper Range Limit	3-16
User-defined Variable	4-3

W

Wiring	2-7
--------	-----

Z

Z-Input Signal	3-12, 3-27
Z-reset Mode, Overflow/Underflow	
Error-code Generation	3-27
Z-reset Mode/Overflow/Underflow	
Error-code Generation	4-17
Z-signal Activated	3-12, 4-16



Automatización Eléctrica
Especialistas en Automatización

Below is a list of articles with direct links to our shop Electric Automation Network where you can see:

- Quote per purchase volume in real time.
- Online documentation and datasheets of all products.
- Estimated delivery time enquiry in real time.
- Logistics systems for the shipment of materials almost anywhere in the world.
- Purchasing management, order record and tracking of shipments.

To access the product, [click on the green button.](#)

Product	Code	Reference	Product link
Control System, Module 4 High Speed Counter	180688	CJ1W-CTL41-E	Buy on EAN
Control System, Block connector 4 Open Collector Inputs Counter	180645	XW2G-40G7-E	Buy on EAN