

The OMRON logo is displayed in a bold, blue, sans-serif font. The letters are thick and rounded, with a consistent blue color throughout. The logo is centered horizontally within a light yellow rectangular background.

**Automatización Eléctrica**  
Especialistas en Automatización

At the end of this document you will find links to products related to this catalog. You can go directly to our shop by clicking [HERE](#). [HERE](#)

NS15-TX\_, NS12-TS\_,  
NS10-TV\_, NS8-TV\_,  
NS5-SQ\_, NS5-TQ\_, NS5-MQ\_

# Programmable Terminals

Host Connection Manual:

Host Link

# OPERATION MANUAL

**OMRON**



# Introduction

---

This manual describes the configuration and settings required for communicating with the host devices used by NS-series Programmable Terminals for Host Link communications.

First familiarize yourself with the contents of the manuals related to NS-series

Programmable Terminals (the *NS-series Setup Manual*, *NS-series Programming Manual*, and the CX-Designer online help), and then use this manual for Host Link communications.



# 1-1 Overview

---

This section provides an overview of connecting an NS-V1/V2 PT to an OMRON Programmable Controller that supports Host Link communications.

The NS-V1/V2 PT is connected 1:1 to the CPU Unit or a Host Link Unit of an OMRON PLC. Host Link communications are used to read and display or write the words and settings in the host PLC.

NS-V1/V2 PT serial ports A and B can both be connected to a host by means of the Host Link protocol.

---

## Reference

When an NS-V1/V2 PT and a PLC are connected by Host Link, it is not possible to change to RUN Mode. If the PLC is set for RUN Mode, it is automatically switched to Monitor Mode. For example, if a compatible Programming Console is connected to the PLC and the PLC operating mode is switched to RUN mode, the password display for the Monitor Mode will be displayed at the Programming Console.

---



## 1-2 Connection Configuration

---

This section describes the system configuration required for connecting to the host by Host Link communications.

### 1-2-1 NS-V1/V2 Configuration Required for Connection

#### ■ NS-V1/V2 Models

One of the following NS-V1/V2 PTs is required to connect with the host by Host Link communications.

Model
NS15-TX01□-V2
NS12-TS0□(B)-V1/-V2
NS10-TV0□ (B)-V1/-V2
NS8-TV0□ (B)-V1/-V2
NS8-TV1□ (B)-V1
NS5-SQ□□ (B)-V1/-V2
NS5-TQ□□ (B)-V2
NS5-MQ□□ (B)-V2

---

#### Reference

NS-series PTs without the -V1 or -V2 suffix do not support Host Link communications. One of the above NS-V1/V2 models must be used.

---

#### ■ NS-V1/V2 System Program

To connect to the host by means of Host Link communications, system program version 6 or later must be installed in the NS-V1/V2 PT.

System program
Ver. 6 or later



■ **Communications Ports**

<b>Communications port</b>	<b>Applicable communications method</b>
Serial port A	Host Link 1:1 NT link 1:N NT link Memory link (Bar-code reader input) (Temperature controller connection) (CX-Designer connection)
Serial port B	Host Link 1:1 NT link 1:N NT link Memory link (Bar-code reader input) (Temperature controller connection) (CX-Designer connection)

The following table shows the communications methods that can be used in combination when serial ports A and B are used at the same time.

		<b>Serial port B</b>						
		<b>Host Link</b>	<b>1:1 NT Link</b>	<b>1:N NT Link</b>	<b>Memory link</b>	<b>Bar-code reader</b>	<b>Temperature controller</b>	<b>CX-Designer connection</b>
<b>Serial port A</b>	<b>Host Link</b>	YES	YES	YES	YES	YES	YES	YES
	<b>1:1 NT link</b>	YES	YES	YES	YES	YES	YES	YES
	<b>1:N NT Link</b>	YES	YES	YES	YES	YES	YES	YES
	<b>Memory link</b>	YES	YES	YES	No	YES	YES	YES
	<b>Bar-code reader</b>	YES	YES	YES	YES	No	YES	YES
	<b>Temperature controller</b>	YES	YES	YES	YES	YES	YES	YES
	<b>CX-Designer connection</b>	YES	YES	YES	YES	YES	YES	No

## ■ Communications Setup

The following table shows the communications settings required at the NS-V1/V2 PT and the host to connect to the host by means of Host Link communications.

Setup location	Settings (See note 2.)
NS-V1/V2 PT	Baud rate: 9,600 or 19,200 bps (See note 1.)
Host	Start bits: 1 bit Data: 7 bits Stop bits: 2 bits Parity: Even Host Link unit number: 0 Baud rate: 9,600 or 19,200 bps (See note 1.)

Note 1: The baud rate settings must be the same for both the NS-V1/V2 PT and the host.

2: Use the 1:N protocol setting.

## 1-2-2 Applicable PLCs

The OMRON PLCs listed below can be connected as hosts using Host Link communications. The connection can be made either directly to the built-in serial port on the CPU Unit or to a Host Link Unit mounted to the PLC.

### ■ C Series

C200HS, C200HX/HG/HE(-Z), CQM1, CQM1H, CPM2A/CPM2C, CPM1/CPM1A, C500, C1000H, C2000H

### ■ CV Series

CV500, CV1000, CV2000, CVM1

### ■ CS/CJ Series

CS1G/CS1H, CS1G-H/CS1H-H, CJ1G, CJ1G-H/CJ1H-H, CJ1M, CP1H/CP1L, CJ2H, CJ2M



# 1-3 Connecting to the Host

The types of host that can be connected to a PT by using the serial ports on the NS-series PT and connecting to an RS-232C port at the host are described here.

## 1-3-1 Connecting to an RS-232C Port at the Host

### ■ Compatible Host Units

Some models and series of OMRON PLCs have the host link function built in.

In the CS-series or CQM1H PLCs, the host link method can be used by installing a Serial Communications Board. In addition, some C200HX/HG/HE(-Z)E have an integral CPU Unit that can be connected in the host link method by installing a Communications Board.

Check the model and series of the PLC, the type of installed Serial Communications Board or Serial Communications Unit before making a connection.

The PLC Units/Boards that can be connected to an NS-series PT through a Host Link connection using RS-232C ports on both the PLC Unit/Board and PT are listed in the following table.

PLC Series	CPU Units with Built-in Host Link Function	CPU Units Connectable with Host Link Units or Expansion Communications Board	Host Link Unit/ Communications Board
CS Series	CS1G-CPU42/43/44/45-EV1 CS1H-CPU63/64/65/66/67-EV1	CS1G-CPU42/43/44/45-EV1 CS1H-CPU63/64/65/66/67-EV1	CS1W-SCU21-V1 CS1W-SCB21-V1 CS1W-SCB41-V1
	CS1G-CPU42H/43H/44H/45H CS1H-CPU63H/64H/65H/66H/67H	CS1G-CPU42H/43H/44H/45H CS1H-CPU63H/64H/65H/66H/67H	
CJ Series	CJ1G-CPU44/CPU45	CJ1G-CPU44/CPU45	CJ1W-SCU21/41-V1
	CJ1G-CPU42H/43H/44H/45H CJ1H-CPU65H/66H/67H CJ1H-CPU65H/66H/67H-R CJ2H-CPU64/65/66/67/68(-EIP)	CJ1G-CPU42H/43H/44H/45H CJ1H-CPU65H/66H/67H CJ1H-CPU65H/66H/67H-R CJ2H-CPU64/65/66/67/68(-EIP)	
	CJ1M-CPU11/12/13/21/22/23 CJ2M-CPU11/12/13/14/15	CJ1M-CPU11/12/13/21/22/23 CJ2M-CPU11/12/13/14/15 /31/32/33/34/35	
		CP1H-XA40DR-A/XA40DT-D/XA40D T1-D/X40DR-A/X40DT-D/X40DT1-D/ Y20DT-D	
		CP1L-L14DR-A/L14DR-D/L14DT-D/L 14DT1-D/L20DR-A/L20DR-D/L20DT- D/L20DT1-D/M30DR-A/M30DR-D/M3 0DT-D/M30DT1-D/M40DR-A/M40DR- D/M40DT-D/M40DT1-D	
C Series		C1000H-CPU01-EV1 C2000H-CPU01-EV1	C120-LK201-EV1
		C200HS-CPU01/03/21/23/31/33-E C200HE-CPU11/32/42-E C200HE-CPU11/32/42-ZE C200HG-CPU33/43/53/63-E C200HG-CPU33/43/53/63-ZE C200HX-CPU34/44/54/64-E C200HX-CPU34/44/54/64/65/85-ZE	C200H-LK201-EV1
	C200HS-CPU21/22/31/33-E		
	C200HE-CPU42-E C200HE-CPU42-ZE	C200HE-CPU32/42-E C200HE-CPU32/42-ZE	C200HW-COM02/04/ 05/06-EV1
	C200HG-CPU43/63-E C200HG-CPU43/63-ZE	C200HG-CPU33/43/53/63-E C200HG-CPU33/43/53/63-ZE	
	C200HX-CPU44/64-E C200HX-CPU44/64/65/85-ZE	C200HX-CPU34/44/54/64-E C200HX-CPU34/44/54/64/65/85-ZE	

PLC Series	CPU Units with Built-in Host Link Function	CPU Units Connectable with Host Link Units or Expansion Communications Board	Host Link Unit/ Communications Board
C Series		C1000H-CPU01-EV1 C2000H-CPU01-EV1	C500-LK201-EV1
		C1000H-CPU01-EV1 C1000HF-CPUA1-EV1 C2000H-CPU01-EV1	C500-LK203
	CPM1-10/20/30CDR-□+CPM1-CIF01		
	CPM1A-10/20/30/40CD□-□+CPM1-CIF01		
	CPM2A-30/40/60CD□□-□+CPM1-CIF01 (Peripheral port connection)		
	CPM2C-10/20□□□□□□-□ (See note 1.)		
	CQM1-CPU21-E CQM1-CPU41/42/43/44-EV1		
	CQM1H-CPU11/21/51/61 (See note 2.)	CQM1H-CPU51/61	CQM1H-SCB41
CV Series (See note 3.)	CV500-CPU01-EV1	CV500-CPU01-EV1	CV500-LK201
	CV1000-CPU01-EV1	CV1000-CPU01-EV1	
	CV2000-CPU01-EV1	CV2000-CPU01-EV1	
CVM1 Series (See note 3.)	CVM1-CPU01-EV2 CVM1-CPU11-EV2 CVM1-CPU21-EV2	CVM1-CPU01-EV2 CVM1-CPU11-EV2 CVM1-CPU21-EV2	CV500-LK201
	SRM1-C02-V2		
	CompoBus/S master control unit		

Note 1: Use a CPM2C-CN111 or CS1W-CN114/118 Connecting Cable, CPM1-CIF01 RS-232C Adapter, or CPM1-CIF11 RS-422A Adapter to connect.

2: The CQM1H-CPU11 does not have a built-in RS-232C port, so connect to the peripheral port to the PT with a CS1W-CN118 Connecting Cable.

3: CPU Units of CVM1/CV-series PLCs without the suffix –EV□ cannot be connected.

## ■ Settings at the Host

When using the host link method, the settings shown below must be made at the host (depending on the unit, some of these settings may not be necessary, or settings not shown here may be necessary).

Item	Switch Setting
I/O port	RS-232C
Communications speed	Set the same baud rate as set at the NS-series PT (See note 1.)
Transfer code	ASCII, 7 data bits, 2 stop bits
Parity	Even
1-to-1/1-to-N	1-to-N (See note 2.)
Command level	Level 1, 2, 3
Unit #	00

Note 1: Set the Host Link communications speed (baud rate) to 9600 bps or 19200 bps with the Communications Setting menu item in the CX-Designer and the System Menu for the NS-series PT. For details, refer to *1-4 Settings for Host Link*.

2: The 1-to-N setting enables using a BCC (Block Check Character). It is not actually possible to connect more than one NS-series PT in a single Host Link.

The setting methods for each type of unit are described in the following.

## Connecting to a C-series Host Link Unit

C200H/C200HS/C200HE(-Z)E/C200HG(-Z)E/C200HX(-Z)E Rack-mounted type: C200H-LK201-V1

### Setting the Front Switches

Set each switch with a flat blade screwdriver so that the values or symbols in the setting value window agree with the following.

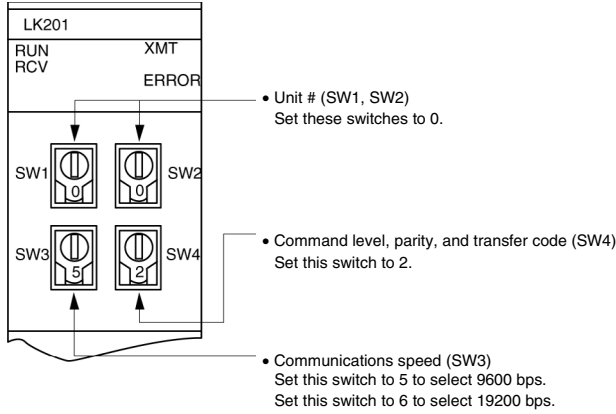

### Setting the Rear Switches

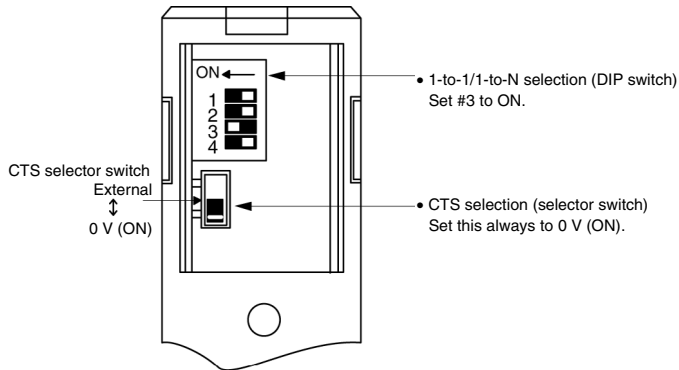

C1000H/C2000H Rack-mounted type: C500-LK201-EV1

### Setting the Front Switches

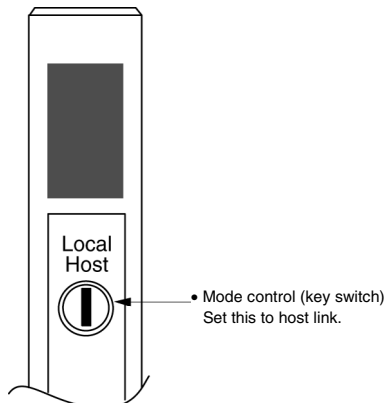

## Setting the Rear Switches

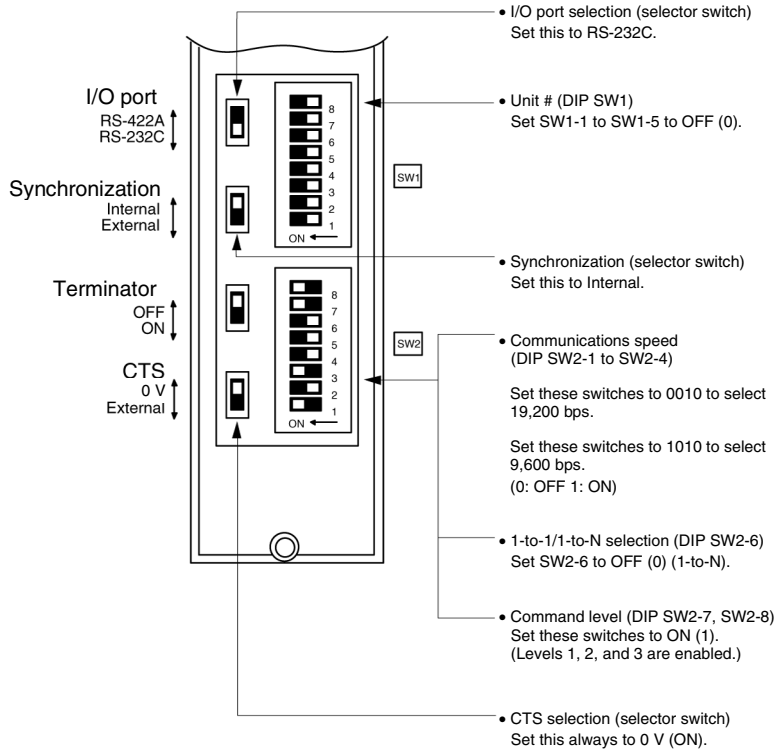

## C1000H(F)/C2000H Rack-mounted type: C500-LK203

### Setting the Rear Switches

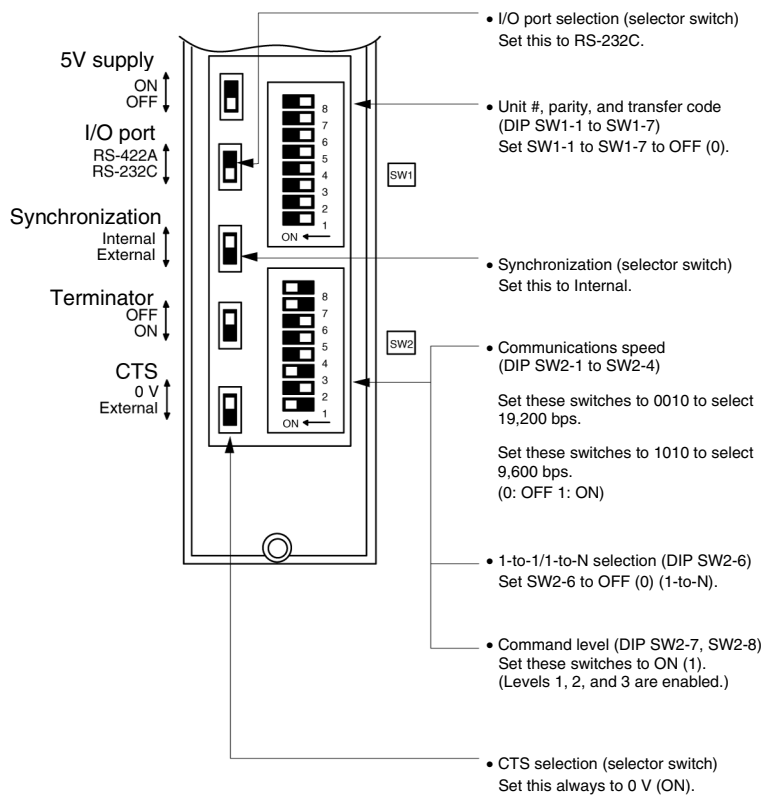

**C200H/C1000H/C2000H CPU Unit-mounted Type: C120-LK201-EV**

**Setting the Rear Switches**

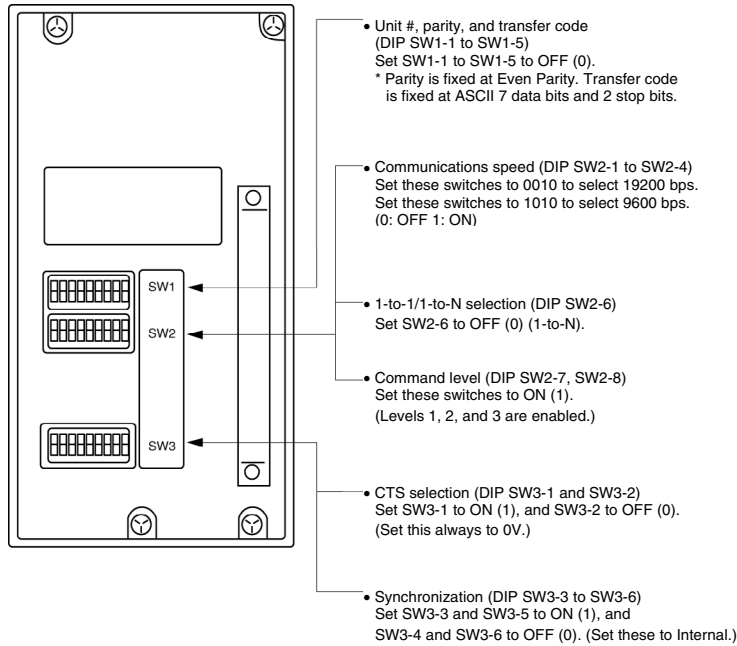

**Connecting to a CVM1/CV Series Host Link Unit**

**CVM1/CV-series Rack-mounted type: CV500-LK201**

A CVM1/CV series host link unit (CV500-LK201) has two connectors (communications ports 1 and 2). Either of these ports can be used for connection to an NS-series PT by the RS-232C method. However, since the connectors at these ports are of different types, a cable that matches the connector must be prepared.

- Communications port 1  
Communications port 1 is a 25-pin connector for RS-232C use only.
- Communications port 2  
Communications port 2 is a 9-pin connector which allows selection of the RS-232C or RS-422A method. When this port is used with the RS-232C method, the I/O port selector switch on the front of the unit must be set to RS-232C (the upper position).

**CPU Bus Unit Settings**

When connecting to a CVM1/CV series host link unit, set the following communications conditions for the CPU Bus Unit settings.

Item	Setting at Host
Communications speed	Set the same baud rate as set at the NS-series PT (See note 1.)
Transfer code	ASCII, 7 data bits, 2 stop bits
Parity	Even

Note 1: Set the Host Link communications speed (baud rate) to 9600 bps or 19200 bps with the Communications Setting menu item in the CX-Designer and the System Menu for the NS-series PT. For details, refer to *1-4 Settings for Host Link*.



Set the CPU Bus Unit settings directly from a Programming Device (e.g. CX-Programmer).  
 For details on the CPU Bus Unit settings, refer to the *SYSMAC CVM1/CV-series Host Link Unit Operation Manual (W205-E1-□)*.

### Setting The Front Switches

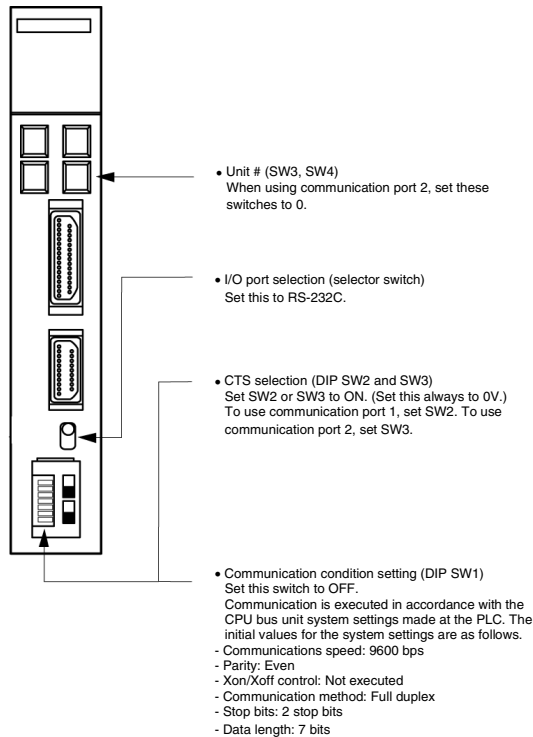

## Connecting to a CS-series Serial Communications Unit

**CS-series Rack-mounted type: CS1W-SCU21(-V1)**

### Setting the Front Switches

Set the unit number of the Serial Communications Unit by using the rotary switch located on the front panel. Set each switch with a flat blade screwdriver so that the values or symbols in the setting value window agree with the following.

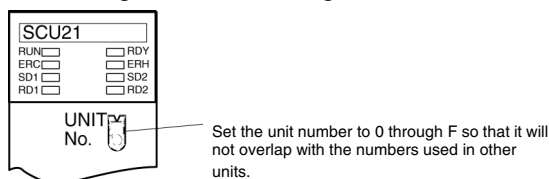

### Allocation DM Area Settings in CPU Unit

Settings are written from the Programming Device (a Programming Console or CX-Programmer) directly into the allocation DM area (system setting area) of the CPU Unit. After the settings are written, they become effective by turning the power ON, restarting the unit, restarting the communications port, or execution of the STUP command.

In the following, the words allocated in the DM area and the settings are shown.

$m = \text{DM } 30000 + 100 \times \text{unit number (word address)}$

Allocation DM area word		Writing Value	Settings
Port 1	Port 2		
m	m+10	8000	Host link mode, 2 stop bits, even parity, data length 7 bits
m+1	m+11	0000	Communications speed 9600 bps.
		0007	Communications speed 19200 bps.
m+2	m+12	0000	Transmit delay time 0 ms.
m+3	m+13	0000	No CTS control Unit No.0 for host link

## Connecting to a CJ-series Serial Communications Unit

### CJ-series Rack-mounted Type: CJ1W-SCU21/41-V1

#### Setting the Front Switches

Set the unit number for the Serial Communications Unit using the rotary switch on the front of the Unit. Follow the procedure below use a flat-head screwdriver (-) to set the number and sign in the setting display window.

Port 2 on the CJ1W-SCU41-V1 is an RS-232C port.

CJ1W-SCU21-V1

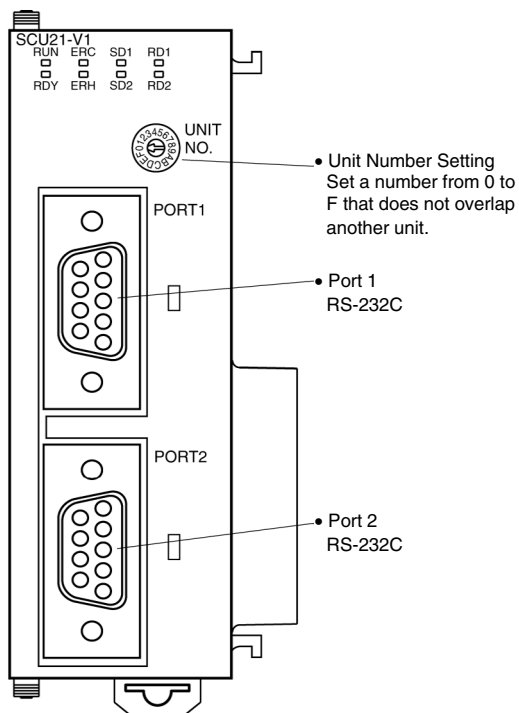

CJ1W-SCU41-V1

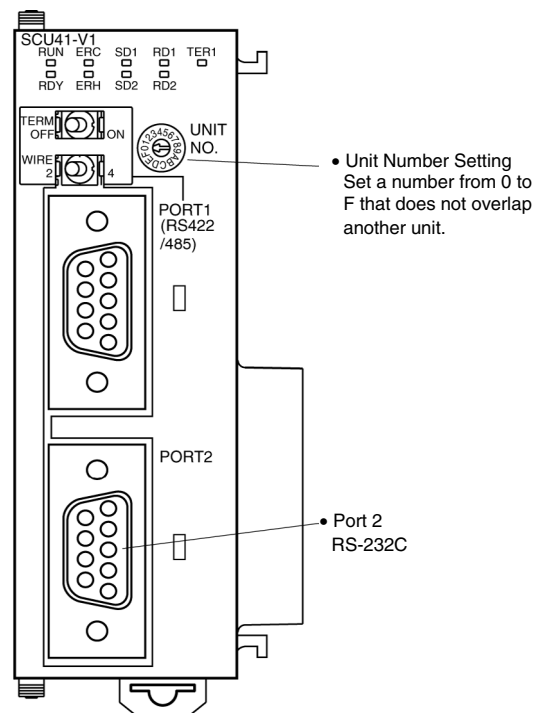

#### Setting CPU Unit Allocation DM Area Words

Settings can be directly written to the Allocation DM Area (System Setup Area) by using a Programming Device, such as a Programming Console or the CX-Programmer. After the settings are written, the settings will become valid by performing any of the following: turning on the power supply again, restarting the Unit, restarting the communications port, or executing a STUP instruction.

The following table shows words allocated in the DM Area and setting details.

$$m = D30000 + 100 \times \text{unit number (word address)}$$

Allocation DM area word		Writing Value	Setting details
Port 1	Port 2		
m	m+10	8000	Host link mode, 2 stop bits, even parity, 7-bit data length
m+1	m+11	0000	Baud rate: 9,600 bps
		0007	Baud rate: 19,200 bps
m+2	m+12	0000	Transmission delay time: 0 ms
m+3	m+13	0000	No CTS control, Unit number 0 for host link

## Connecting to a CPU Unit

### CV-series and CVM1/CV-series (-EV□) CPU Units

CV500-CPU01-EV1/CV1000-CPU01-EV1/CV2000-CPU01-EV1

CVM1-CPU01-EV2/CVM1-CPU11-EV2/CVM1-CPU21-EV2

### PLC Setup

When connecting to a CVM1/CV series CPU Unit, set the following communications conditions for the PLC Setup.

Item	Setting at Host
Communications speed	Set the same baud rate as set at the NS-series PT (See note.)
Stop bit	2 stop bits
Parity	Even
Data length	ASCII 7 bits
Unit #	00

Note: Set the Host Link communications speed (baud rate) to 9600 bps or 19200 bps with the Communications Setting menu item in the CX-Designer and the System Menu for the NS-series PT. For details, refer to *1-4 Settings for Host Link*.

Either set PLC Setup directly from a Programming Device (e.g. CX-Programmer), or transmit the PLC Setup made at a Programming Device to the CPU UNIT.

For details on the PLC Setup, refer to the *SYSMAC CVM1/CV500/1000/2000 Operation Manual: Ladder Diagrams (W202-E1-□)*.

## Setting the Front Switches

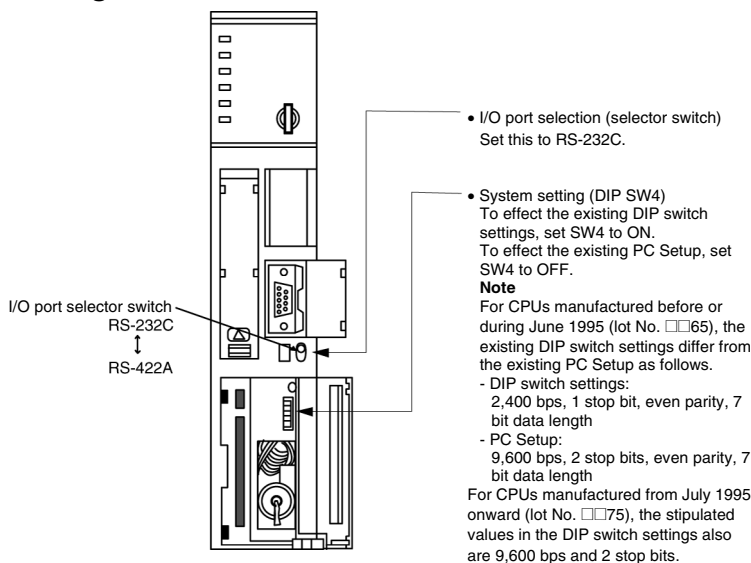

### C-series C200HS, C200HX/HG/HE(-Z)E, CPM1, CPM2A, CPM2C, CQM1, CQM1H CPU Units, SRM1

The connection method depends upon the model of PLC being used, as shown in the following table.

PLC model	Connection method
C200HS, CQM1	Connect to the CPU Unit's built-in RS-232C port.
C200HX/HG/HE(-Z)E	<ul style="list-style-type: none"> <li>• Connect to the CPU Unit's built-in RS-232C port.</li> <li>• Connect to one of the RS-232C ports (port A or port B) on a Serial Communications Board.</li> </ul>
CQM1H	<ul style="list-style-type: none"> <li>• Connect to the CPU Unit's built-in RS-232C port.</li> <li>• Connect to the peripheral port through a CS1W-CN118 Connecting Cable.</li> <li>• Connect to the RS-232C port (port 1) on a Serial Communications Board.</li> </ul>
CPM1	Connect to the peripheral port through a CPM1-CIF01 RS-232C Adapter.
CPM2A, SRM1	<ul style="list-style-type: none"> <li>• Connect to the CPU Unit's built-in RS-232C port.</li> <li>• Connect to the peripheral port through a CPM1-CIF01 RS-232C Adapter.</li> </ul>
CPM2C	Connect to the CPU Unit's RS-232C port or the peripheral port through a Connecting Cable (CPM2C-CN111, CS1W-CN118, or CS1W-CN114). (The CPM2C-CN111 splits the Unit's communications port into an RS-232C port and a peripheral port. A CPM1-CIF01 RS-232C Adapter is also required to connect to this peripheral port.)

### PLC Setup Area Settings

When connecting to a C200HS, C200HX/HG/HE(-Z)E, CPM1, CPM2A, CPM2C, CQM1, or CQM1H CPU Unit, or SRM1, set the following communications conditions for the PLC Setup area.

Item	Setting at Host
Communications mode	Host link mode
Communications speed	Set the same baud rate as set at the NS-series PT (See note.)
Stop bit	2 stop bits

Item	Setting at Host
Parity	Even
Data length	ASCII 7 bits
Unit #	00

Note: Set the Host Link communications speed (baud rate) to 9600 bps or 19200 bps with the Communications Setting menu item in the CX-Designer and the System Menu for the NS-series PT. For details, refer to *1-4 Settings for Host Link*.

Set the PLC Setup area settings directly from a Programming Device (e.g. CX-Programmer). For details on operations relating to the PLC Setup area, refer to the manual for the PLC which is used.

The PLC Setup area word numbers and settings to be made depending on the unit and port to which the connection is made are shown below.

CPM2A, CPM2C, CQM1H, or SRM1: Peripheral port connection

Word	Writing Value	Settings
DM6650	0001	Host link mode, no CTS control, communications conditions set by the contents of DM
DM6651	0303	Data length 7 bits, 2 stop bits, even parity, communications speed: 9600 bps
	0304	Data length 7 bits, 2 stop bits, even parity, communications speed: 19200 bps
DM6653	0000	Unit # 00

C200HS, C200HX/HG/HE(-Z)E, CPM2A, CPM2C, CQM1, CQM1H (other than the CPU11), or SRM1: Built-in RS-232C port connection

Word	Writing Value	Settings
DM6645	0001	Host link mode, no CTS control, communications conditions set by the contents of DM
DM6646	0303	Data length 7 bits, 2 stop bits, even parity, communications speed: 9600 bps
	0304	Data length 7 bits, 2 stop bits, even parity, communications speed: 19200 bps
DM6648	0000	Unit # 00

C200HX/HG/HE(-Z)E: Serial Communications Board port A, CQM1H: Serial Communications Board port 1

Word	Writing Value	Settings
DM6555	0001	Host link mode, no CTS control, communications conditions set by the contents of DM area
DM6556	0303	Data length 7 bits, 2 stop bits, even parity, communications speed: 9600 bps
	0304	Data length 7 bits, 2 stop bits, even parity, communications speed: 19200 bps
DM6558	0000	Unit # 00

## C200HX/HG/HE(-Z)E: Board Port B Connection

Word	Writing Value	Settings
DM6550	0001	Host link mode, no CTS control, communications conditions set by the contents of DM
DM6551	0303	Data length 7 bits, 2 stop bits, even parity, communications speed: 9600 bps
	0304	Data length 7 bits, 2 stop bits, even parity, communications speed: 19200 bps
DM6553	0000	Unit # 00

## CPM1 Connection

Word	Writing Value	Settings
DM6650	0001	Host link mode, communications conditions set by the contents of DM area
DM6651	0303	Data length 7 bits, 2 stop bits, even parity, communications speed: 9600 bps
	0304	Data length 7 bits, 2 stop bits, even parity, communications speed: 19200 bps
DM6653	0000	Unit # 00

## Connecting to a CPM2C

The CPM2C PLCs do not have the same kind of port connectors found on CS-series PLCs. The CPM2C's communications port handles both RS-232C and peripheral port connections which are divided internally. Therefore, when using the CPM2C, it is necessary to select RS-232C or peripheral port connections, according to the kind of cable and port (on the cable) used, as shown in the following table. Refer to the *CPM2C Operation Manual* for more details.

Port connecting to PT	PLC Setup
RS-232C port (D-Sub 9-pin) of CPM2C-CN111	Built-in RS-232C port settings
Peripheral port of CPM2C-CN111	Peripheral port settings
RS-232C port (D-Sub 9-pin) of CS1W-CN118	Built-in RS-232C port settings
Peripheral port of CS1W-CN114	Peripheral port settings

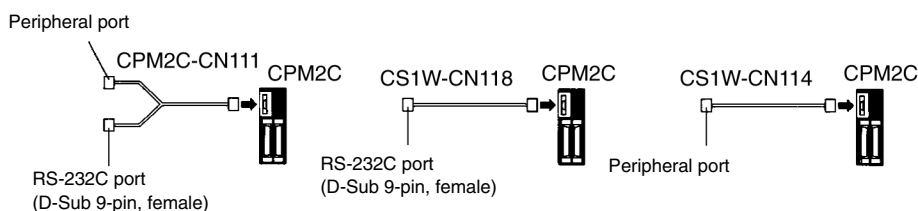

## Setting the DIP Switches of a C200HX/HG/HE(-Z)E, CQM1 or CQM1H

When using a C200HX/HG/HE(-Z)E, CQM1, or CQM1H the DIP switches on the front panel must be set as shown below in order to make the settings in the PLC Setup area (data memory) effective.

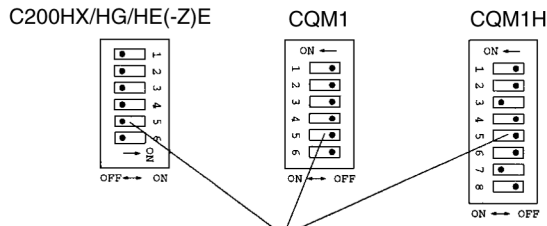

RS-232C port communication condition setting  
 Set DIP SW5 to OFF to make the settings made in PC Setup effective.

When using the CQM1H's built-in peripheral port, turn ON SW7.

### Setting the Switches of a CPM2A

When using a CPM2A, the switches on the front panel must be set as shown below in order to make the PLC Setup settings effective.

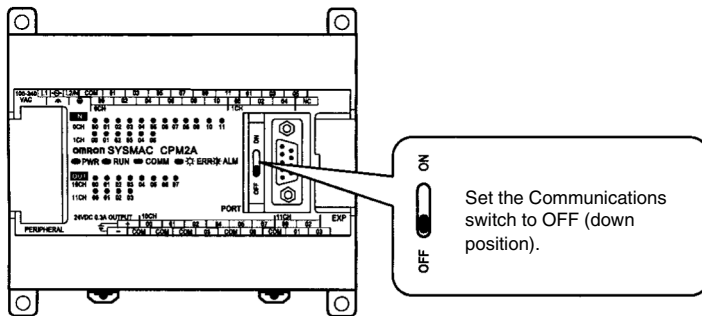

### Setting the Switches of a CPM2C

When using a CPM2C, the switches on the front panel must be set as shown below in order to make the PLC Setup settings effective.

The settings for SW1 and SW2 depend upon the usage of the peripheral port and RS-232C port.

- Connecting PT to peripheral port
- Connecting PT to built-in RS-232C port  
 (A device that requires non-standard communications settings is connected to the peripheral port.)

SW1: OFF  
 SW2: ON

- Connecting PT to built-in RS-232C port  
 (A Programming Console is connected to the peripheral port.)

SW1: OFF  
 SW2: OFF

### Setting the Switches on a RS-232C Adapter

When using a CPM1-CIF01 RS-232C Adapter, set the mode switch as shown in the following diagram.



### CS-series CPU Unit type: CS1G/H-CPU-EV1, CS1G/H-H

Connect to the built-in RS-232C port of the CPU Unit, or the RS-232C port of the Communications Board. Note that the connection to a peripheral port must be made via an RS-232C adapter (CS1W-CN118) specially designed for connecting to a peripheral port.

### PLC Setup

When connecting to a CS-series CPU Unit, set the following communications conditions for the PLC Setup area. Since the settings shown below are the PLC default settings for the CPU Unit, no change to the PLC Setup is necessary as long as the communications speed is maintained at 9600 bps.

Item	Setting at Host
Communications speed	Set the same baud rate as set at the NS-series PT (See note.)
Stop bits	2 stop bits
Parity	Even
Data length	ASCII 7 bits
Unit No. for the host link	00

Note: Set the Host Link communications speed (baud rate) to 9600 bps or 19200 bps with the Communications Setting menu item in the CX-Designer and the System Menu for the NS-series PT. For details, refer to *1-4 Settings for Host Link*.

When the communications speed is set to 19200 bps., the PLC Setup of the CPU Unit need to be changed.

Either set the PLC Setup directly from a Programming Device (Programming Console), or transmit the PLC Setup made at a Programming Device (CX-Programmer) to the CPU Unit. For details on PLC Setup, refer to the *SYSMAC CS series Operation Manual (W339-E1-□)*.

When using the built-in RS-232C port of CS1G/H

Word #	Writing Value	Settings
160	8000	Host link mode, data length 7 bits, 2 stop bits, even parity
161	0000	Communications speed: 9600 bps.
	0007	Communications speed: 19200 bps.
166	0000	Unit #00

When using the peripheral port of CS1G/H

Word #	Writing Value	Settings
144	8000	Host link mode, data length 7 bits, 2 stop bits, even parity
145	0000	Communications speed: 9600 bps.
	0007	Communications speed: 19200 bps.
150	0000	Unit #00

### Setting the Front Switches

Set the CPU Unit DIP switches to 4 or 5 in accordance with the port the NS-Series PT is connected to.



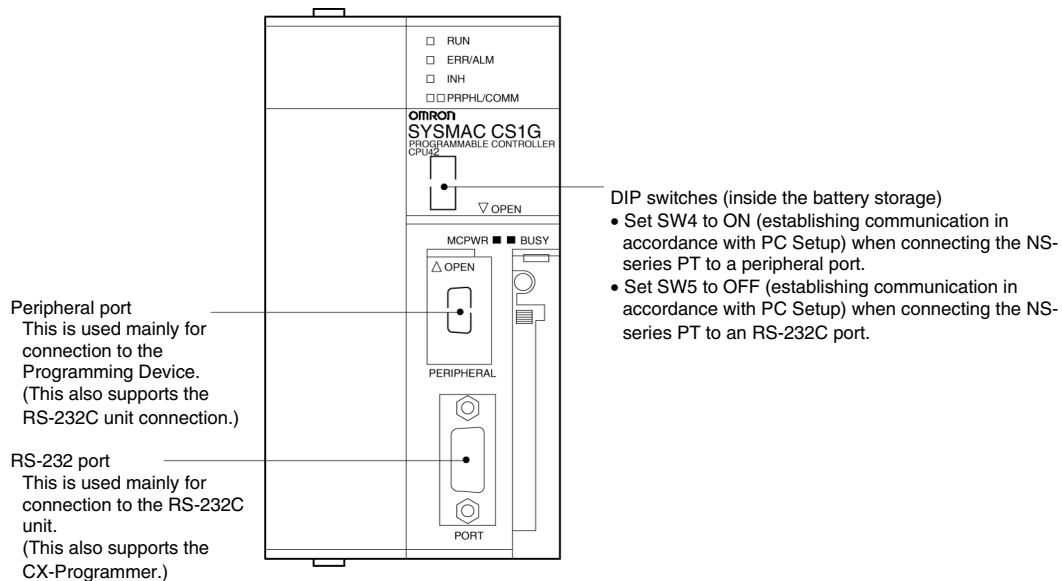

## Connecting to CS1 Series Serial Communications Board

**Serial Communications Board equipped with an RS-232C port for CS-series CPU Units: CS1W-SCB41/21-V1**

### Allocation DM Area Settings in CPU Unit

Settings are written from the Programming Device (a Programming Console or CX-Programmer) directly into the allocation DM area (system setting area) of the CPU Unit. After the settings are written, they become effective by turning the power ON, restarting the unit, restarting the communications port, or execution of the STUP command.

In the following, the words allocated in the DM area and the settings are shown.

Allocation DM area word		Writing Value	Settings
Port 1	Port 2		
D32000	D32010	8000	Host link mode, 2 stop bits, even parity, data length 7 bits
D32001	D32011	0000	Communications speed 9600 bps.
		0007	Communications speed 19200 bps.
D32002	D32012	0000	Transmit delay time 0 ms.
D32003	D32013	0000	No CTS control, Unit No. 0 for host link

## 1-3-2 Connecting to an RS-422A/485 Port at the Host

### Compatible Host Units

Some models and series of OMRON PLCs have the RS-422A type host link function built in. With the CS-series and CQM1H, the host link method can be used by installing a serial Communications Board. In addition, some C200HX/HG/HE(-Z)E devices have an integral CPU Unit that can be connected in the host link method by installing a Communications Board.

With the CPM2A and CPM2C, an RS-422A type of 1:1 NT Link can be created through a CPM1-CIF11 RS-422A Adapter.

Check the model and series of the PLC and the type of the installed Board or Unit before making a connection.

The PLC Units that provide an RS-422A Host Link interface and that can be connected to an NS-series PT port to which an RS-232C/RS422A Link Adaptor (NS-AL002) is connected are listed in the following table.

PLC Series	CPU Units with Built-in Host Link Function	CPU Units Connectable with Host Link Units or Expansion Communications Board	Host Link Unit/ Communications Board
CS Series		CS1G-CPU42/43/44/45-EV1 CS1H-CPU63/64/65/66/67-EV1	CS1W-SCB41-V1
		CS1G-CPU42H/43H/44H/45H CS1H-CPU63H/64H/65H/66H/67H	
CJ Series		CJ1G-CPU44/CPU45	CJ1W-SCU41-V1
		CJ1G-CPU42H/43H/44H/45H CJ1H-CPU65H/66H/67H CJ1H-CPU65H/66H/67H-R CJ2H-CPU64/65/66/67/68(-EIP)	
		CJ1M-CPU11/12/13/21/22/23 CJ2M-CPU11/12/13/14/15/31/32/33/34/35	
		CP1H-XA40DR-A/XA40DT-D/XA40DT1-D/X40DR-A/X40DT-D/X40DT1-D/Y20DT-D	
		CP1L-L14DR-A/L14DR-D/L14DT-D/L14DT1-D/L20DR-A/L20DR-D/L20DT-D/L20DT1-D/M30DR-A/M30DR-D/M30DT-D/M30DT1-D/M40DR-A/M40DR-D/M40DT-D/M40DT1-D	
C Series		C1000H-CPU01-EV1 C2000H-CPU01-EV1	C120-LK202-EV1
		C200HS-CPU01/03/21/23/31/33-E C200HE-CPU11/32/42-E C200HE-CPU11/32/42-ZE C200HG-CPU33/43/53/63-E C200HG-CPU33/43/53/63-ZE C200HX-CPU34/44/54/64-E C200HX-CPU34/44/54/64/65/85-ZE	C200H-LK202-EV1
		C200HE-CPU32/42-E C200HE-CPU32/42-ZE	C200HW-COM03/06-EV1
		C200HG-CPU33/43/53/63-E C200HG-CPU33/43/53/63-ZE	
		C200HX-CPU34/44/54/64-E C200HX-CPU34/44/54/64/65/85-ZE	
		C1000H-CPU01-EV1 C2000H-CPU01-EV1	C500-LK201-EV1
		C1000H-CPU01-EV1 C1000HF-CPUA1-EV1 C2000H-CPU01-EV1	C500-LK203

PLC Series	CPU Units with Built-in Host Link Function	CPU Units Connectable with Host Link Units or Expansion Communications Board	Host Link Unit/ Communications Board
C Series	CPM1-10/20CDR-□+CPM1-CIF11		
	CPM1A-10/20/30/40CD□-□+CPM1-CIF11		
	CPM2A-30/40/60CD□□-□+CPM1-CIF11 (Peripheral port connection)		
	CPM2C-10/20□□□□□□-□ (See note 1.)		
		CQM1H-CPU51/61	CQM1H-SCB41
CV Series (See note 2.)	CV500-CPU01-EV1	CV500-CPU01-EV1	CV500-LK201
	CV1000-CPU01-EV1	CV1000-CPU01-EV1	
	CV2000-CPU01-EV1	CV2000-CPU01-EV1	
CVM1 Series (See note 2.)	CVM1-CPU01-EV2	CVM1-CPU01-EV2	CV500-LK201
	CVM1-CPU11-EV2	CVM1-CPU11-EV2	
	CVM1-CPU21-EV2	CVM1-CPU21-EV2	
SRM1	SRM1-C02-V2+CPM1-CIF11		

Note 1: Use a CPM2C-CN111 or CS1W-CN114/118 Connecting Cable, CPM1-CIF01 RS-232C Adapter, or CPM1-CIF11 RS-422A Adapter to connect.

2: CPU Units of CVM1/CV-series PLCs without the suffix -EV□ cannot be connected.

The RS-485 interface (2-wire method) provided by NS-series PTs is for connecting to an OMRON Temperature Controller. Do not connect it to an NS-series PT or PLCs using RS-485.

## ■ Settings at the Host

When using the RS-422A type host link method, the settings shown below must be made at the host (depending on the unit, some of these settings may not be necessary, or settings not shown here may be necessary).

Item	Setting at Host
I/O port	RS-422A
Communications speed	Set the same baud rate as set at the NS-series PT (See note 1.)
Transfer code	ASCII, 7 data bits, 2 stop bits
Parity	Even
1-to-1/1-to-N	1-to-N (See note 2.)
Command level	Level 1, 2, 3
Unit #	00

Note 1: Set the Host Link communications speed (baud rate) to 9600 bps or 19200 bps with the Communications Setting menu item in the CX-Designer and the System Menu for the NS-series PT. For details, refer to *1-4 Settings for Host Link*.

2: The 1-to-N setting enables using a BCC (Block Check Character). It is not actually possible to connect more than one NS-series PT in a single Host Link.

The setting methods for each type of unit are described in the following.

## Connecting to a C Series Host Link Unit

C200H/C200HS/C200HE(-Z)E/C200HG(-Z)E/C200HX(-Z)E Rack-mounted Type: C200H-LK202-V1

### Setting the Front Switches

Set each switch with a flat blade screwdriver so that the values or symbols in the setting value window agree with the following:

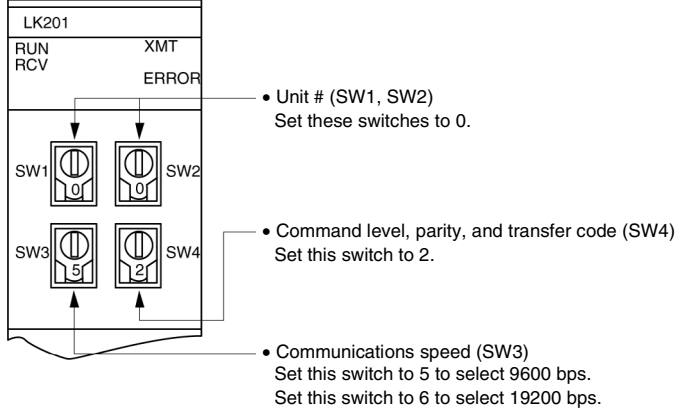

### Setting the Rear Switches

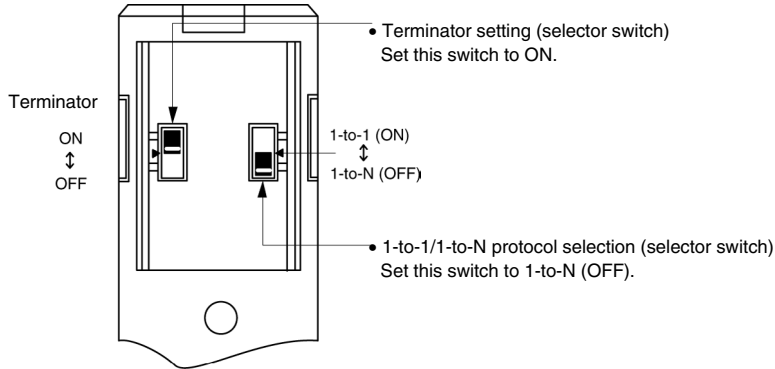

**C1000H/C2000H Rack-mounted Type: C500-LK201-EV1**

**Setting the Front Switches**

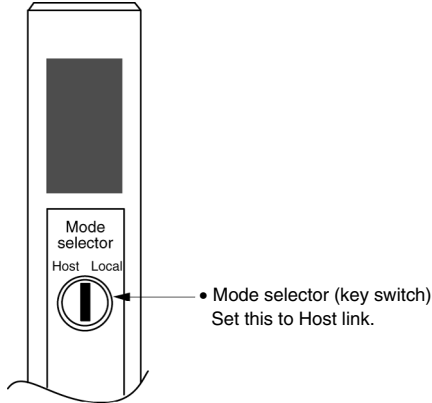

**Setting the Rear Switches**

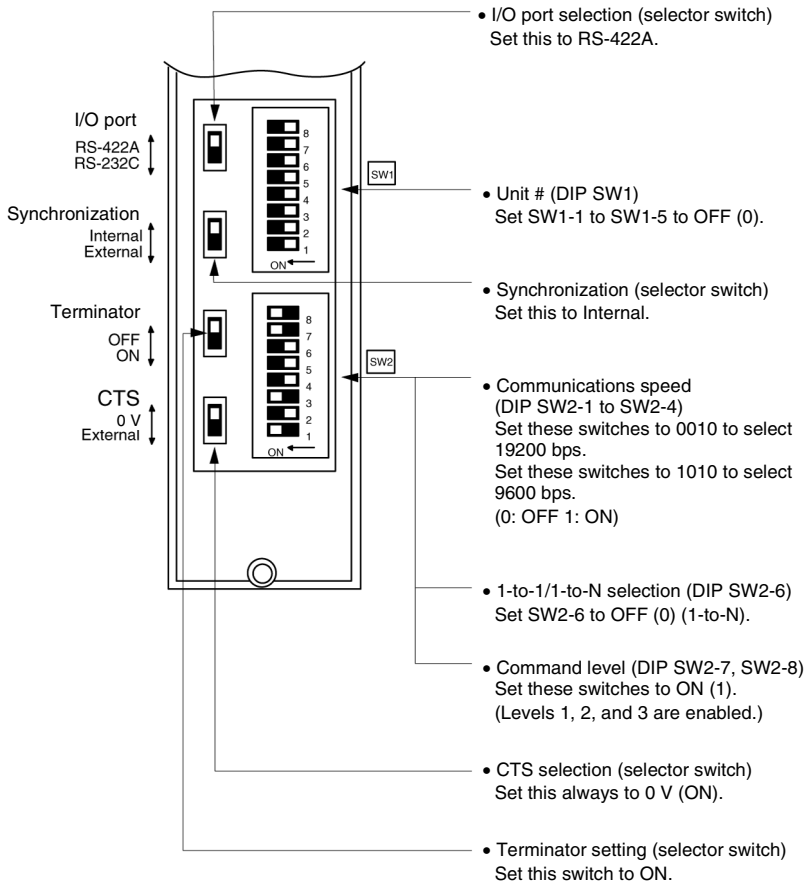

**C1000H(F)/C2000H Rack-mounted Type: C500-LK203**

**Setting the Rear Switches**

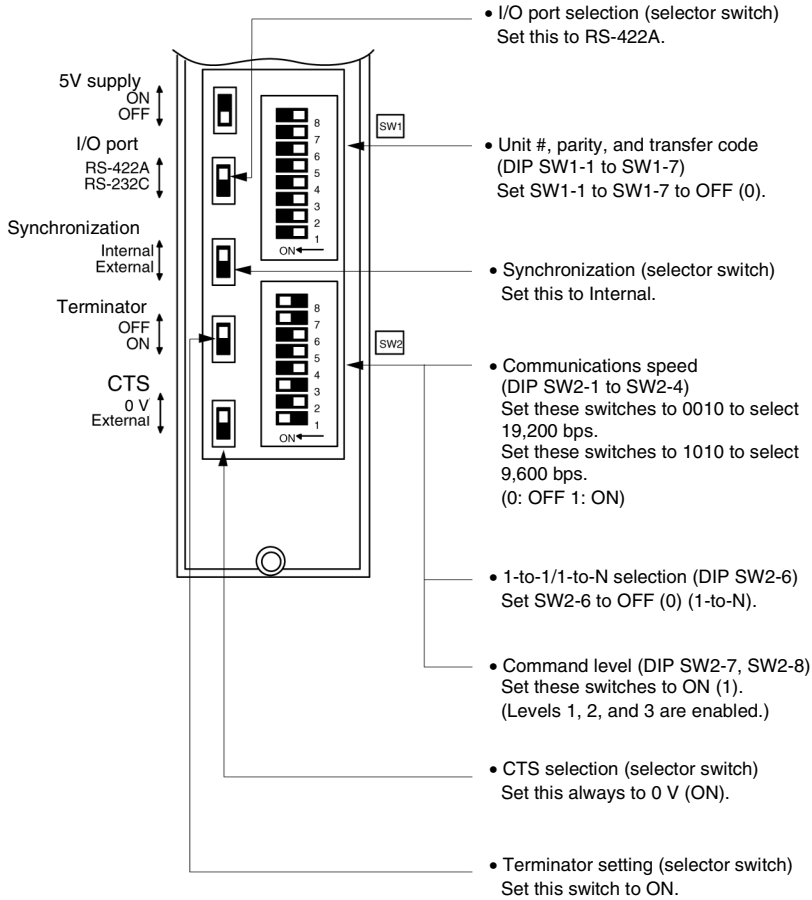

**C200H/C1000H/C2000H CPU-mounted Type: C120-LK202-EV1**

**Setting the Rear Switches**

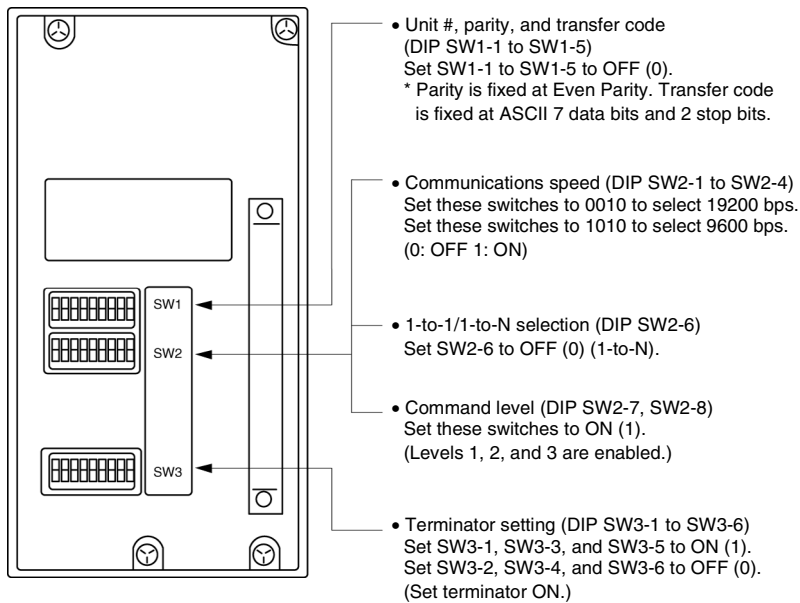

## Connecting to a CVM1/CV Series Host Link Unit

### CVM1/CV series Rack-mounted Type: CV500-LK201

A CVM1/CV series host link unit (CV500-LK201) has two connectors (communications ports 1 and 2). To use the RS-422A type host link method, set communications port 2 to RS-422A.

Communications port 2 is a 9-pin connector which allows selection of the RS-232C or RS-422A method. When this port is used with the RS-422A method, the I/O port selector switch on the front of the unit must be set to RS-422A (the lower position).

### CPU Bus Unit Settings

When connecting to a CVM1/CV series host link unit, set the following communications conditions for the CPU Bus Unit settings.

Item	Setting at Host
Communications speed	Set the same baud rate as set at the NS-series PT (See note 1.)
Transfer code	ASCII, 7 data bits, 2 stop bits
Parity	Even

Note 1: Set the Host Link communications speed (baud rate) to 9600 bps or 19200 bps with the Communications Setting menu item in the CX-Designer and the System Menu for the NS-series PT. For details, refer to *1-4 Settings for Host Link*.

Set the CPU Bus Unit settings directly from a Programming Device (e.g., CX-Programmer).

For details on the CPU Bus Unit settings, refer to the *SYSMAC CVM1/CV-series Host Link Unit Operation Manual (W205-E1-□)*.

## Setting the Front Switches

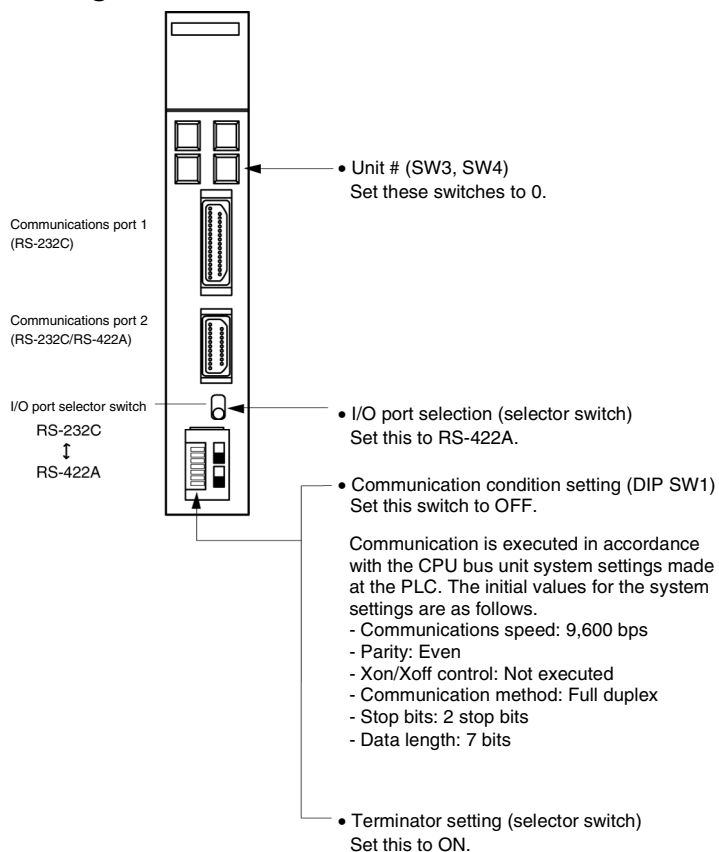

## Connecting to a CPU Unit

### CVM1/CV-series (-EV□) CPU Units

- CV500-CPU01-EV1/CV1000-CPU01-EV1/CV2000-CPU01-EV1
- CVM1-CPU01-EV2/CVM1-CPU11-EV2/CVM1-CPU21-EV2

### PLC Setup

When connecting to a CVM1/CV-series CPU Unit, set the following communications conditions for the PLC Setup.

Item	Setting at Host
Communications speed	Set the same baud rate as set at the NS-series PT (See note.)
Stop bit	2 stop bits
Parity	Even
Data length	ASCII 7 bits
Unit #	00

Note: Set the Host Link communications speed (baud rate) to 9600 bps or 19200 bps with the Communications Setting menu item in the CX-Designer and the System Menu for the NS-series PT. For details, refer to *1-4 Settings for Host Link*.

Either set the PLC Setup directly from a Programming Device (e.g. CX-Programmer), or transmit the PLC Setup made at a Programming Device to the CPU Unit.

For details on the PLC Setup, refer to the *SYSMAC CVM1/CV500/CV1000/ CV2000 Operation Manual: Ladder Diagrams (W202-E1-□)*.



## Setting the Front Switches

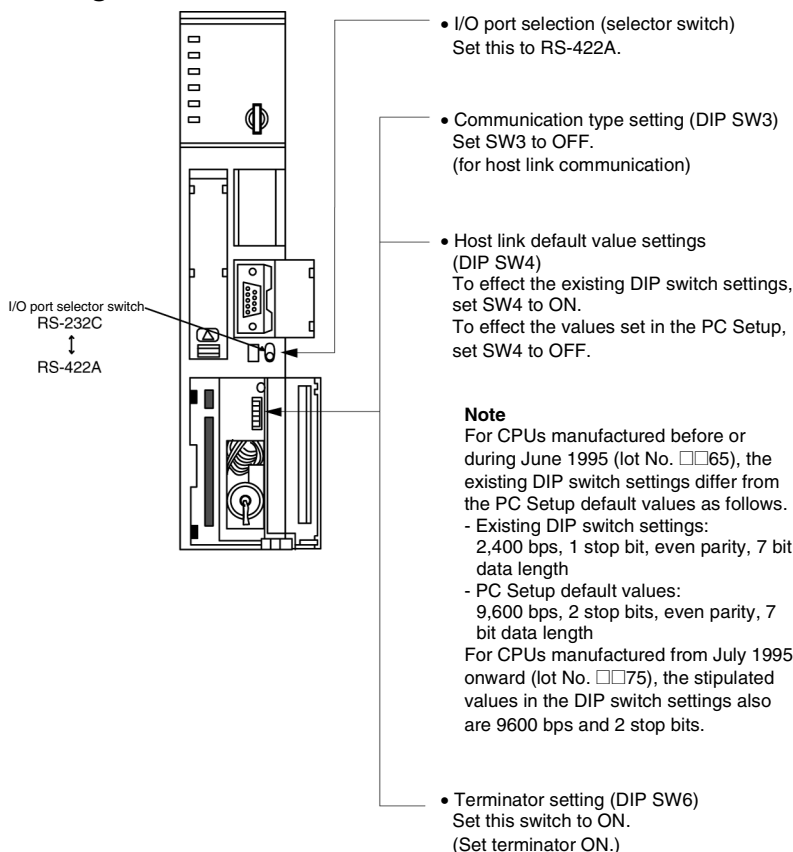

## C-series C200HX/HG/HE(-Z)E, CPM1, CPM2A, CPM2C, CQM1H, CPU Unit or SRM1

The connection method depends upon the model of PLC being used, as shown in the following table.

PLC model	Connection method
C200HX/HG/HE(-Z)E	• Connect to the RS-422A port (port A) on a Communications Board.
CQM1H	• Connect to the RS-422A port (port 2) on a Serial Communications Board.
CPM1	• Connect to the peripheral port through a CPM1-CIF11 RS-422A Adapter.
CPM2A, SRM1	• Connect to the peripheral port through a CPM1-CIF11 RS-422A Adapter.
CPM2C	• Connect to the peripheral port (on a CPM2C-CN111 or CS1W-CN114 Connecting Cable) through a CPM1-CIF11 RS-422A Adapter. (The CPM2C-CN111 splits the Unit's communications port into a RS-232C port and a peripheral port.)

## Reference

- There are no Communications Boards for the C200HX/HG/HE(-Z)E in which port B is the RS-422A port.
- There are no Serial Communications Boards for the CQM1H in which port 1 is the RS-422A port.

## PLC Setup Area Settings

When connecting to a C200HX/HG/HE(-Z)E or CPM1, CPM2A, CPM2C, CQM1H CPU Units or SRM1, set the following communications conditions for the PLC Setup area.

Item	Setting at Host
I/O port	RS-422A
Communications mode	Host link mode
Communications speed	Set the same baud rate as set at the NS-series PT (See note.)
Stop bit	2 stop bits
Parity	Even
Data length	ASCII 7 bits
Unit #	00

Note: Set the Host Link communications speed (baud rate) to 9600 bps or 19200 bps with the Communications Setting menu item in the CX-Designer and the System Menu for the NS-series PT. For details, refer to *1-4 Settings for Host Link*.

Set the PLC Setup area settings directly from a Programming Device (e.g. CX-Programmer). For details on operations relating to the PLC Setup area, refer to the manual for the PLC which is used.

The PLC Setup area word numbers and settings to be made depending on the unit to which the connection is made are shown below.

When using port A of the Communications Board of C200HX/HG/HE(-Z)E

Word #	Writing Value	Settings
DM6555	0001	Host link mode, no CTS control, communications conditions set by the contents of DM area
DM6556	0303	Data length 7 bits, 2 stop bits, even parity, communications speed: 9600 bps
	0304	Data length 7 bits, 2 stop bits, even parity, communications speed: 19200 bps
DM6558	0000	Unit # 00

When using a CPM1, CPM2A, CPM2C, SRM1

Word #	Writing Value	Settings
DM6650	0001	Host link mode, no CTS control, communications conditions set by the contents of DM area
DM6651	0303	Data length 7 bits, 2 stop bits, even parity, communications speed: 9600 bps
	0304	Data length 7 bits, 2 stop bits, even parity, communications speed: 19200 bps
DM6653	0000	Unit # 00

When using a CQM1H

Word #	Writing Value	Settings
DM6550	0001	Host link mode, no CTS control, communications conditions set by the contents of DM area
DM6551	0303	Data length 7 bits, 2 stop bits, even parity, communications speed: 9600 bps
	0304	Data length 7 bits, 2 stop bits, even parity, communications speed: 19200 bps
DM6553	0000	Unit # 00

### Connecting to a CPM2C

The CPM2C PLCs do not have the same kind of port connectors found on CS-series PLCs. The CPM2C's communications port handles both RS-232C and peripheral port connections which are divided internally. Therefore, when using the CPM2C, it is necessary to select RS-232C or peripheral port connections, according to the kind of cable and port (on the cable) used, as shown in the following table. Refer to the CPM2C Operation Manual for more details.

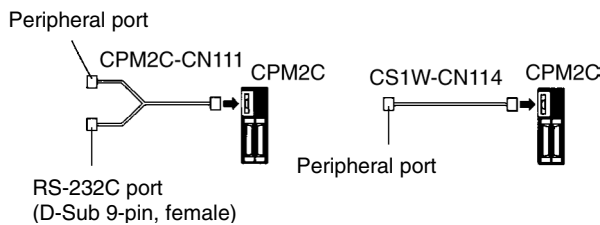

### Setting Switches on a C200HX/HG/HE(-Z)E Communications Board

Set the switches on a C200HX/HG/HE(-Z)E Communications Board as follows.

Switch 1: Set to 4 (4-wire type, for RS-422A)

Switch 2: Set to ON for terminator ON (termination resistance applied)

### Setting Switches on a CQM1H Serial Communications Board

Set the switches on a CQM1H Serial Communications Board as follows.

2-wire/4-wire selection (WIRE): Set to 4 (4-wire type, for RS-422A)

Terminator (TERM): Set to ON for termination ON (termination resistance applied).

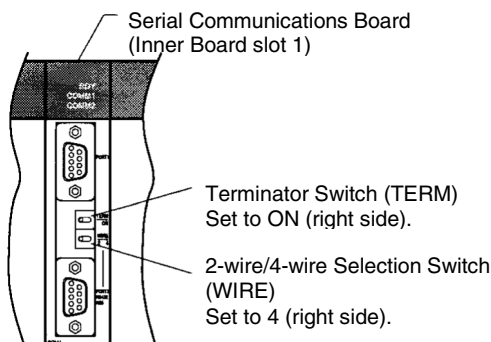

## Setting the Switches on an RS-422A Adapter

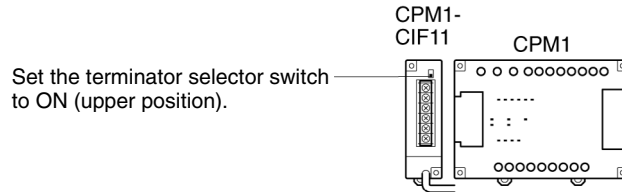

## Connecting to a CS-series Serial Communications Board

Serial Communications Board with an RS-422A/485 port equipped for CS-series CPU Unit Type: CS1W-SCB41(-V1) (The port 2 is an RS-422A/485 port.)

### Allocation DM Area Settings in CPU Unit

Settings are written from the Programming Device (a Programming Console or CX-Programmer) directly into the allocation DM area (system setting area) of the CPU Unit. After the settings are written, they become effective by turning the power ON, restarting the unit, restarting the communications port, or executing the STUP command.

In the following, the words allocated in the DM area and the settings are shown.

Allocation DM area word	Writing Value	Settings
<b>Port 2</b>		
D32010	8000	Host link mode, 2 stop bits, data length 7 bits, even parity,
D32011	0000	Communications speed 9600 bps.
	0007	Communications speed 19200 bps.
D32012	0000	Transmit delay time 0 ms.
D32013	0000	No CTS control, Unit No. 0 for host link

## Connecting to a CJ-series Serial Communications Unit

**CJ-series Rack-mounted Serial Communications Unit: CJ1W-SCU41-V1**  
**(Port 1 is an RS-422A/ 485 port.)**

### Setting the Front-panel Switches

Set the unit number for the Serial Communications Unit using the rotary switch on the front panel of the Unit. Use a flat-head screwdriver to set the unit number in the setting display window.

Set the terminator switch to ON (right side).

Set the 2-wire/4-wire selection switch to 4 (right side).

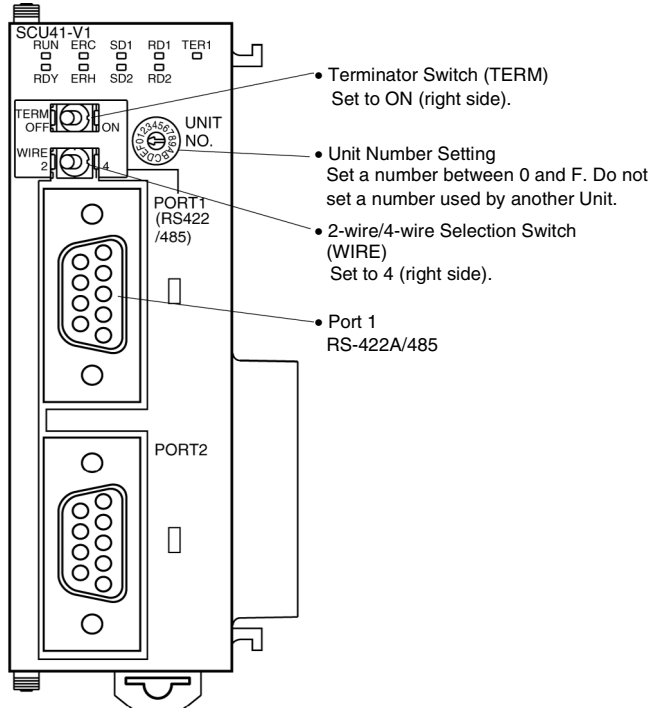

### Setting Parameters Allocated in the DM Area in the CPU Unit

Settings can be directly written to the words allocated to the Serial Communications Unit in the DM Area (System Setup Area) by using a Programming Device, such as a Programming Console or the CX-Programmer. Any changes to the settings can be enabled by cycling the power supply, restarting the Unit, restarting the communications port, or executing a STUP instruction.

The following table lists the words allocated in the DM Area and setting details.

$$M = D30000 + 100 \times \text{unit number (word address)}$$

Allocation DM Area word		Write value	Setting details
Port 1	Port 2		
m	M+10	8000	Host Link mode, 2 stop bits, even parity, 7-bit data
M+1	M+11	0000	Baud rate: 9,600 bps
		0007	Baud rate: 19,200 bps
M+2	M+12	0000	Transmission delay time: 0 s
M+3	M+13	0000	No CTS control, unit number 0 for Host Link

## 1-4 Settings for Host Link

This section describes the procedure for making the NS-V1 PT settings for connecting to the host by means of Host Link communications.

Use either serial port A or B. The flow of operations for connecting to the host is as follows:

- (1) Design the screen data.
- (2) Transfer the screen data.
- (3) Set the communications method for serial port A or B
- (4) Connect to the host.

### 1-4-1 Designing the Screen Data

Use the CX-Designer to create the screen data. First, select **Communication Setting** from the PT Menu to display the Communication Setting Dialog Box.

Select *Serial Port A* or *Serial Port B*. Then set the serial port to *PLC* and the protocol to *Host Link*.

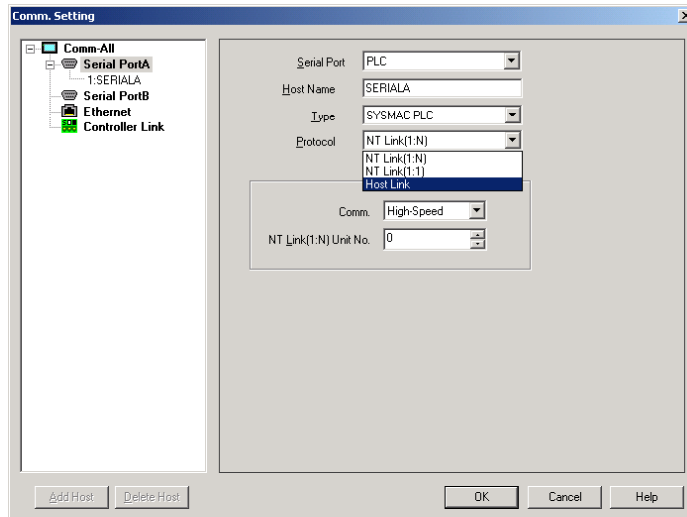

### 1-4-2 Transferring Screen Data

Use the transfer program to transfer the screen data to the NS-V1/V2 PT.

For details on transferring screen data, refer to *Transferring Data to the PT* in the CX-Designer online help.

### 1-4-3 Setting the Communications Method for Serial Port A or B

This procedure is not required if the method has already been set in *1-4-1 Designing the Screen Data* above. At the NS-V1/V2 PT, set Host Link as the communications method for the serial port that is to be used to connect to the host by means of Host Link communications. Also set the baud rate to same value as the host.

These settings are made from the NS-V1/V2 PT's System Menu.

- (1) Press the **Comm.** Tab in the System Menu to display the Communications Setup Screen.  
(For the NS5 PT, press the **Comm.** Button in the System Menu to display the screen, and then press the ← and → **Screen Switching** Buttons to display the screen for page (2/3).
- (2) Press the drop-down menu button and set Host Link as the communications method for serial port A or B.
- (3) Press the **Detail** Button to display the Host Link settings, and select **Comm. Speed**.
- (4) Press the **Write** Button and press the **Yes** Button on the following dialog boxes to restart the NS-V1/V2.

## ■ NS15/NS12/NS10/NS8-V1/V2 PT

(The screen is somewhat different for the NS15/12.)

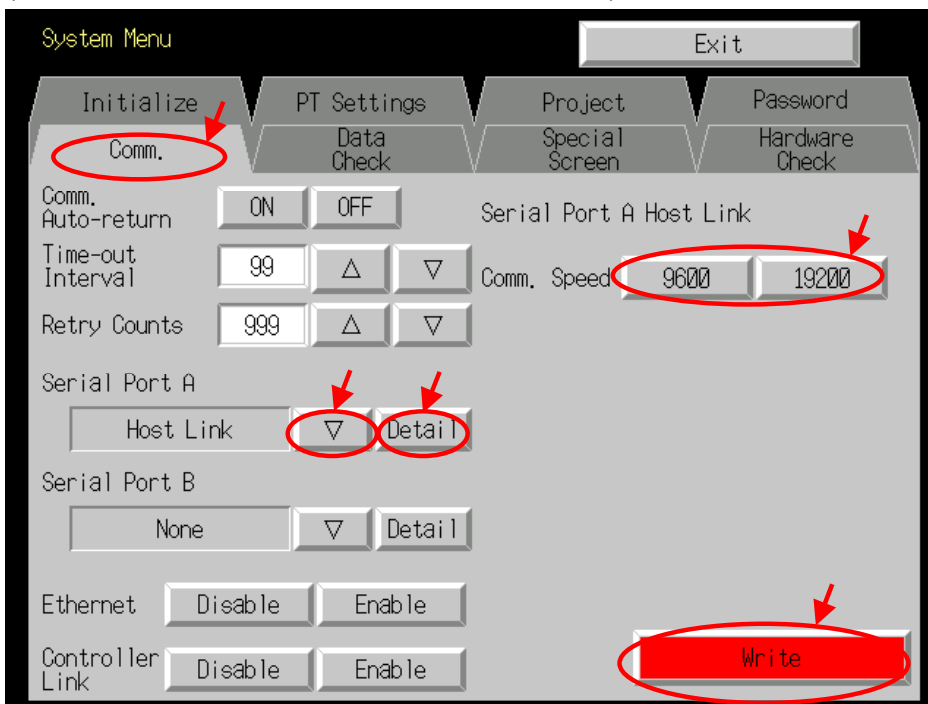

## ■ NS5

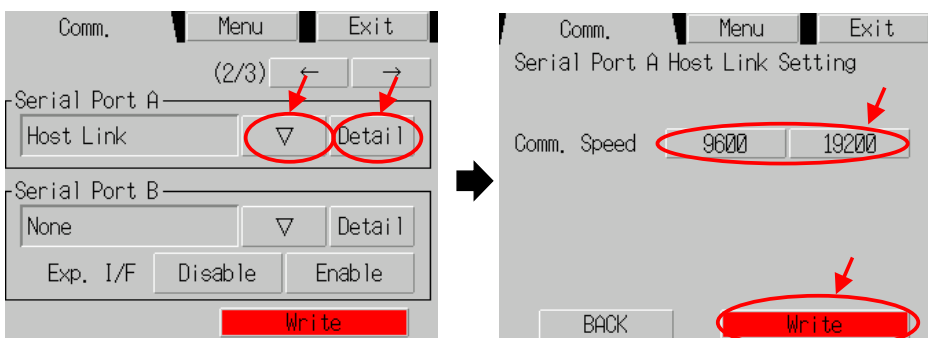

#### **1-4-4 Connecting to the Host**

Connect in the same way as for a 1:1 NT Link, and use the same cables that are used for a 1:1 NT Link connection.

If cables must be prepared, refer to the relevant manuals for the PLC or Host Link Unit, and to the *NS Series Setup Manual* (Cat. No. V083).





# 1-5 PLC Areas That Can Be Used for Communications

## ■ OMRON C-series PLCs

PLC model		Common I/O Area (CIO)	Holding Relay (HR)	Auxiliary Relay (AR)	Link Relay (LR)	Timer/Counter Area (TIM/CNT)	Data Memory Area (DM)	EM Area (Current bank) (EM)
Ladder type PLCs	C200HS	00000	00000	00000	00000	00000	00000	-
	C200HE/HG/HX(-Z)	to 00511	to 00099	to 00027	to 00063	to 00511	to 06655 07000 to 09999	00000 to 06143
	C500	00000 to 00063	00000 to 00031	-	00000 to 00031	00000 to 00127	00000 to 00511	-
	C1000H	00000 to 00255	00000 to 00099	00000 to 00027	00000 to 00063	00000 to 00511	00000 to 04095	-
	C2000H CQM1						00000 to 06655	-
	CQM1H						00000 to 06655	00000 to 06143
	CPM1/CPM1A	00000 to 00019 00200 to 00255	00000 to 00019	00000 to 00015	00000 to 00015	00000 to 00127	00000 to 01023 06144 to 06655	-
	CPM2A/CPM2C	00000 to 00049 00200 to 00255		00000 to 00023		00000 to 00255	00000 to 02047 06144 to 06655	-

■ **CVM1/CV-series PLCs**

PLC model	Common I/O Area (CIO)	Holding Relay (HR) (See note 1.)	Auxiliary Relay (AR)	Link Relay (LR)	Timer/Counter Area (TIM/CNT)	Data Memory Area (DM)	EM Area (Current bank) (EM) (See note 2.)
CV500 CVM1-CPU01-V□	00000 to 02555	-	00000 to 00511	-	00000 to 00511	00000 to 08191	-
CVM1-CPU11-V□	00000 to 02555	-	00000 to 00511	-	00000 to 01023	00000 to 09999	-
CV1000 CV2000 CVM1-CPU11-V□ CVM1-CPU21-V□	00000 to 02555	-	00000 to 00511	-	00000 to 01023	00000 to 09999	-

Note 1: The HR Area is included in the CIO Area. To use the HR Area, specify the CIO Area.

2: Do not use this area for creating screens. It cannot be used with Host Link communications.

■ **OMRON CS/CJ-series PLCs**

PLC model	Common I/O Area (CIO)	Holding Relay (HR)	Auxiliary Relay (AR)	Link Relay (LR)	Timer/Counter Area (TIM/CNT)	Data Memory Area (DM)	EM Area (Current bank) (See note 1.)
CS1G/H(-H) CJ1G/H(-H) CJ1M CP1L CP1H CJ2H CJ2M	00000 to 06143	00000 to 00511	00000 to 00959	-	00000 to 02047	00000 to 09999	00000 to 09999
	Work Area (WR) (See note 2.)						
	-						

Note 1: The EM Area cannot be specified for the CJ1M.

2: Do not use this area for creating screens. It cannot be used with Host Link communications.

# 1-6 Restrictions

---

## ■ Applicable Project Versions

When connecting to the host by means of Host Link communications, use version 6.0 or later for creating the screen data (project) to be transferred to the NS-V1/V2 PT.

To use a project of version 5.x or earlier, first use CX-Designer to convert the project to version 6.0 or later before transferring it to the NS-V1/V2 PT.

## ■ Applicable Serial Ports

Either NS-V1/V2 serial port A or B can be used to connect to the host by means of Host Link communications.

## ■ Applicable NS Models

Only NS-series PT models with a -V1/V2 suffix can be used to connect to the host by means of Host Link communications. NS-series PT models without the -V1/V2 suffix cannot be connected.

# Revision History

---

The following table outlines the changes made to the manual during each revision. Page numbers refer to the previous version.

<b>Cat. No.</b>	<b>V098-E1-05</b>
-----------------	-------------------

↑  
Revision Code

Revision code	Date	Revised content
01	July 2004	Original production
02	July 2006	Revisions made for the release of the CX-Designer.
03	July 2007	Pages 6 and 20: CJ-series CPU Unit model numbers added.
04	June 2008	Cover: Added models to list of NS-series PT. Page 3: Added 3 models to end of model table in section 1-2-1. Page 5: Added CJ2H to list of CS/CJ-series PLCs. Pages 6 and 19: Added models to CJ-series PLCs in table. Page 26: Added CJ2H to PLC models listed in table.
05	October 2010	Revisions made for the release of the CX-Designer.

Below is a list of articles with direct links to our shop Electric Automation Network where you can see:

- Quote per purchase volume in real time.
- Online documentation and datasheets of all products.
- Estimated delivery time enquiry in real time.
- Logistics systems for the shipment of materials almost anywhere in the world.
- Purchasing management, order record and tracking of shipments.

To access the product, [click on the green button.](#)

Product	Code	Reference	Product link
Control system, CPU 24/16 E / S Relay outputs AC 4EA 2SA	209397	CP1H-XA40DR-A	<a href="#">Buy on EAN</a>
Control system, CPU 8/6 E / S AC relay outputs	237098	CP1L-L14DR-A	<a href="#">Buy on EAN</a>
Control system, CPU 5120 E / S 20KW 64kW RS232C Data	135643	CS1H-CPU63H	<a href="#">Buy on EAN</a>
Control system, CPU RS232C 5K steps	392391	CJ2M-CPU11	<a href="#">Buy on EAN</a>
Control System, Cable Peripherals	224547	CPM2C-CN111	<a href="#">Buy on EAN</a>
Control System, Console Cable CQM1	224561	CS1W-CN114	<a href="#">Buy on EAN</a>
Control System, Card 1 + 1 RS232C RS422	296511	CS1W-SCB41-V1	<a href="#">Buy on EAN</a>
Control System, Module 2 RS232C	296512	CS1W-SCU21-V1	<a href="#">Buy on EAN</a>
Operator interface, RS232 to RS422 converter for NS (500 m) (Not isolated)	113738	NS-AL002	<a href="#">Buy on EAN</a>
Control system, CPU 160 E / S 5Kpasos 32KW	184018	CJ1M-CPU11	<a href="#">Buy on EAN</a>
Control system, CPU 960 E / S data 10KW 64kW	135641	CS1G-CPU42H	<a href="#">Buy on EAN</a>
Control system, CPU 2560 E / S 50 160 Kw Data kSteps	268696	CJ2H-CPU64	<a href="#">Buy on EAN</a>
Control system, PC Cable 10cm	224559	CS1W-CN118	<a href="#">Buy on EAN</a>