



Automatización Eléctrica

Especialistas en Automatización

At the end of this document you will find links to products related to this catalog. You can go directly to our shop by clicking HERE. [HERE](#)

Side height 85

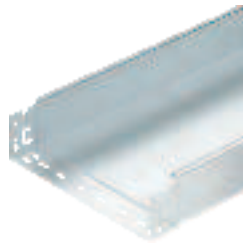

Cable tray SKS-Magic®, unperforated

Type	Width mm	Plate thickness mm	Length mm	Useful cross- section cm²	Appr. load:			Weight kg/100 m	Item No.
					1.5 m	2.0 m	3.0 m		
SKSMU 810 FS	100	1.5	3,050	83	2.8	2.25	0.75	345.570	6059 76 2
SKSMU 815 FS	150	1.5	3,050	125	2.8	2.25	0.75	404.260	6059 76 4
SKSMU 820 FS	200	1.5	3,050	186	2.8	2.25	0.75	463.270	6059 76 6
SKSMU 830 FS	300	1.5	3,050	253	2.8	2.25	0.75	580.980	6059 76 8
SKSMU 840 FS	400	1.5	3,050	338	2.8	2.25	0.75	698.680	6059 77 0
SKSMU 850 FS	500	1.5	3,050	423	2.8	2.25	0.75	816.390	6059 77 2
SKSMU 860 FS	600	1.5	3,050	508	2.8	2.25	0.75	934.100	6059 77 4
SKSMU 810 FT	100	1.5	3,050	83	2.8	2.25	0.75	366.550	6059 77 9
SKSMU 815 FT	150	1.5	3,050	125	2.8	2.25	0.75	428.520	6059 78 1
SKSMU 820 FT	200	1.5	3,050	186	2.8	2.25	0.75	474.750	6059 78 3
SKSMU 830 FT	300	1.5	3,050	253	2.8	2.25	0.75	616.060	6059 78 5
SKSMU 840 FT	400	1.5	3,050	338	2.8	2.25	0.75	740.980	6059 78 7
SKSMU 850 FT	500	1.5	3,050	423	2.8	2.25	0.75	865.570	6059 78 9
SKSMU 860 FT	600	1.5	3,050	508	2.8	2.25	0.75	990.490	6059 79 1

St Steel FS Strip-galvanised FT Hot-dip galvanised /m

SKSMU 85 = Heavy-duty Magic cable tray system, unperforated, with 85 mm side height.

Unperforated cable tray with quick connection system, including all the relevant connection components for time-saving and economic installation.

The stock length is 3,050 mm, the usable length when combined is 3,000 mm.

The spring element FED 60 can be ordered separately as an accessory part (spare) for the Magic cable trays with a side height of 60 mm, 85 mm and 110 mm under the article number 6068859.

The continuous equipotential bonding is guaranteed without additional components. VDE-tested cable tray system.

Load diagram, cable tray, type SKSMU 85

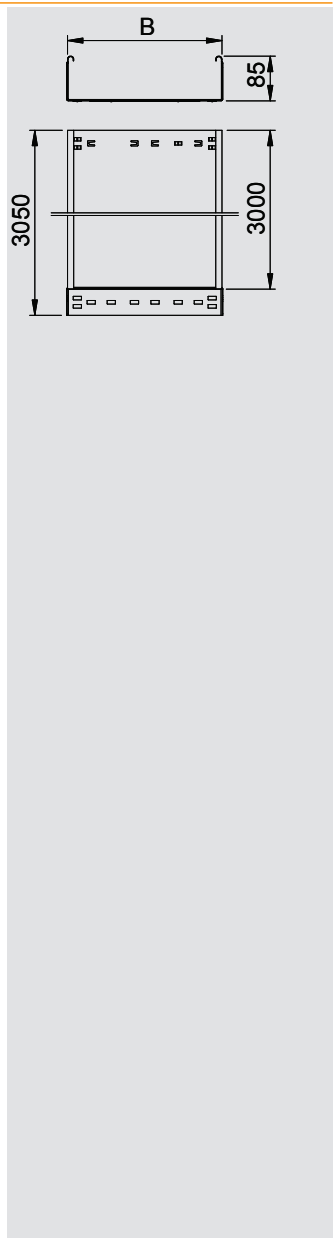
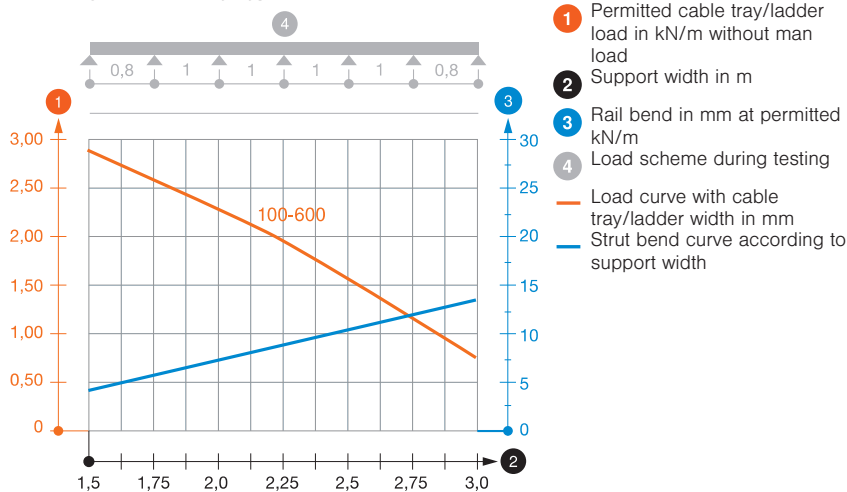

Barrier strip

Type	Dimen- sion H mm	Plate thickness mm	Dimen- sion L mm	Pack. m	Weight kg/100 m	Item No.
TSG 85 FS	85	0.75	3,000	3	70.300	6062 11 4
TSG 85 DD	85	0.75	3,000	3	70.300	6062 33 1

St Steel FS Strip-galvanised DD Zinc-aluminium coated, double-dip /m

Barrier strip for separation of cables of different voltages or functions.

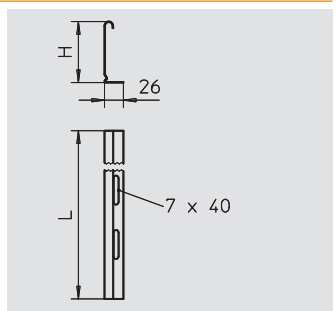

Barrier strip connector

Type	Pack. pcs	Weight kg/100 pcs.	Item No.
TSGV VA4310	10	1.000	6067 97 0

V2A Stainless steel, grade 301 /pc.

Barrier strip connector for screwless connection of the TSG barrier strip in all side heights.

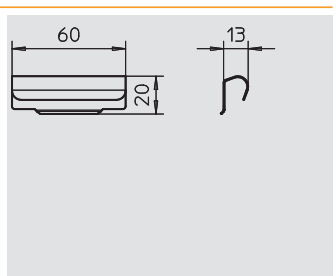



Below is a list of articles with direct links to our shop Electric Automation Network where you can see:

- Quote per purchase volume in real time.
- Online documentation and datasheets of all products.
- Estimated delivery time enquiry in real time.
- Logistics systems for the shipment of materials almost anywhere in the world.
- Purchasing management, order record and tracking of shipments.

To access the product, [click on the green button.](#)

Product	Code	Reference	Product link
Cable tray SKSMU unperf. with quick connector, 85x100x3050, Strip-galvanised, DIN EN 10147, Steel, St	6059762	SKSMU 810 FS	Buy on EAN
Cable tray SKSMU unperf. with quick connector, 85x150x3050, Strip-galvanised, DIN EN 10147, Steel, St	6059764	SKSMU 815 FS	Buy on EAN
Cable tray SKSMU unperf. with quick connector, 85x200x3050, Strip-galvanised, DIN EN 10147, Steel, St	6059766	SKSMU 820 FS	Buy on EAN
Cable tray SKSMU unperf. with quick connector, 85x300x3050, Strip-galvanised, DIN EN 10147, Steel, St	6059768	SKSMU 830 FS	Buy on EAN
Cable tray SKSMU unperf. with quick connector, 85x400x3050, Strip-galvanised, DIN EN 10147, Steel, St	6059770	SKSMU 840 FS	Buy on EAN
Cable tray SKSMU unperf. with quick connector, 85x500x3050, Strip-galvanised, DIN EN 10147, Steel, St	6059772	SKSMU 850 FS	Buy on EAN
Cable tray SKSMU unperf. with quick connector, 85x600x3050, Strip-galvanised, DIN EN 10147, Steel, St	6059774	SKSMU 860 FS	Buy on EAN
Cable tray SKSMU unperf. with quick connector, 85x100x3050, Hot-dip galvanised, DIN EN ISO 1461, Steel, St	6059779	SKSMU 810 FT	Buy on EAN
Cable tray SKSMU unperf. with quick connector, 85x150x3050, Hot-dip galvanised, DIN EN ISO 1461, Steel, St	6059781	SKSMU 815 FT	Buy on EAN
Cable tray SKSMU unperf. with quick connector, 85x200x3050, Hot-dip galvanised, DIN EN ISO 1461, Steel, St	6059783	SKSMU 820 FT	Buy on EAN
Cable tray SKSMU unperf. with quick connector, 85x300x3050, Hot-dip galvanised, DIN EN ISO 1461, Steel, St	6059785	SKSMU 830 FT	Buy on EAN
Cable tray SKSMU unperf. with quick connector, 85x400x3050, Hot-dip galvanised, DIN EN ISO 1461, Steel, St	6059787	SKSMU 840 FT	Buy on EAN

Cable tray SKSMU unperf. with quick connector, 85x500x3050, Hot-dip galvanised, DIN EN ISO 1461, Steel, St	6059789	SKSMU 850 FT	Buy on EAN
Cable tray SKSMU unperf. with quick connector, 85x600x3050, Hot-dip galvanised, DIN EN ISO 1461, Steel, St	6059791	SKSMU 860 FT	Buy on EAN
Barrier strip for cable tray and cable ladder, 85x3000, Strip-galvanised, DIN EN 10147, Steel, St	6062114	TSG 85 FS	Buy on EAN
Barrier strip for cable tray and cable ladder, 85x3000, Zinc-aluminium coated, double-dip, Steel, St	6062331	TSG 85 DD	Buy on EAN