

LUXOMAT® Ecolight 18-SP and 26-SP



18-SP



26-SP

TECHNICAL DATA

- 230V~ ±10%
- IP44 / Class II / CE
- 18-SP**
L 80 x W 220 x H 470 mm
- 26-SP**
L 80 x W 220 x H 550 mm
- 25°C to +50°C
- made of high-quality and UV-resistant polycarbonate

Lamps

- 18-SP** PL18W/G24q-2
Luminous flux 1.200 lm
- 26-SP** PL26W/G24q-3
Luminous flux 1.800 lm

PRODUCT INFORMATION

- **LUXOMAT® Ecolight 18-SP and Ecolight 26-SP** energy-saving floodlight with earth spike
- Approx. 80% lower energy consumption when an 18 W energy-saving lamp is used compared with a 100 W conventional lamp
- Energy-saving lamps last longer: around 12,000 hours compared with conventional lamps (approx. 1,000 hours); therefore very low maintenance costs
- Very low intrinsic heating due to the electronic ballast's minimal dissipation loss
- Very high light yield thanks to special reflectors
- Including 2 m connecting cable with plug **CEE 7/7**
- **Application examples:** lighting for gardens, paths, green spaces, beer gardens

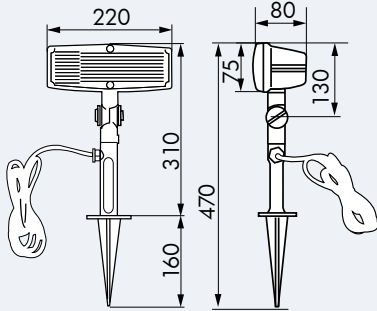

Ecolight 18-SP

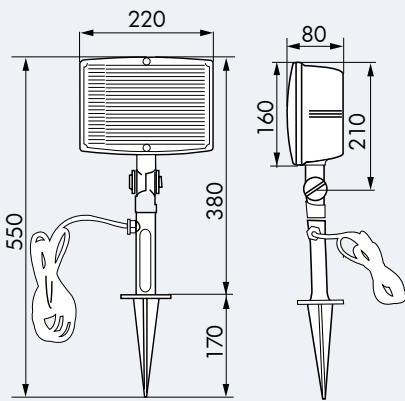

Ecolight 26-SP

Light distribution Ecolight 18 W

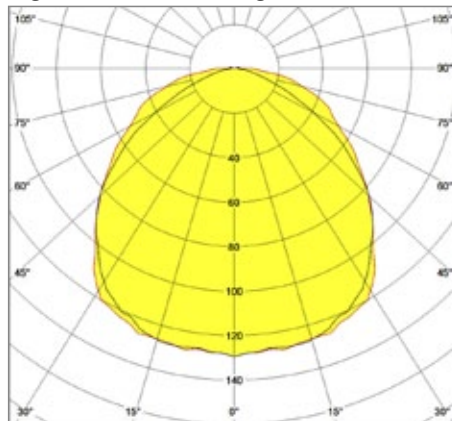

Light distribution Ecolight 26 W

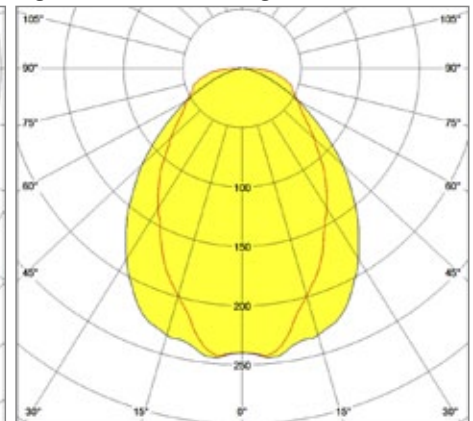

Energy and environment balance sheet see page 42

Description	Colour	Part number
Ecolight 18-SP	black	21020
Ecolight 26-SP	black	22020

OUTDOOR FLOODLIGHTS