



**Automatización Eléctrica**

Especialistas en Automatización

At the end of this document you will find links to products related to this catalog. You can go directly to our shop by clicking [HERE](#). [HERE](#)

# Interference suppressing transformer **STT 100**



Picture shows STT 400

## Advantages

Good attenuation against radio frequency interference and pulses
Low magnetic leakage field
Integrated short circuit and overload protection
Very good moisture protection and low noise thanks to resin encapsulation
High degree of protection
Carrying handle, mains connecting lead and socket for mobile use

## Applications

Mains transformer complying with EN 61558-2-4 for portable application to minimize mains supply faults such as disturbing pulses and electrical noise.

## Sample application

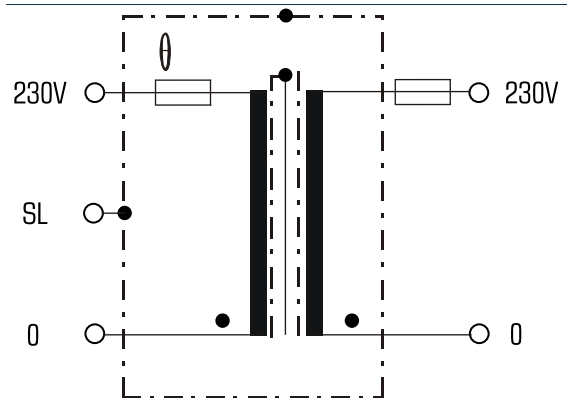

## Standards



Mains transformer  
to: VDE 0570 Teil 2-1, DIN EN 61558-2-1, EN 61558-2-1, IEC 61558-2-1

## Approvals



# Interference suppressing transformer STT 100

Type		STT 100
<b>Electrical data</b>	<b>Input</b>	
	Rated input voltage	230 Vac
	Rated frequency	50 - 60 Hz
	<b>Output</b>	
	Rated output voltage	230 Vac
	Rated Power	100 VA
	No-load voltage (app. x factor)	1.06
	Leakage cur. (PRI-PE)	43 µA (typ.)
	Efficiency	89 %
	Leakage cur. (PRI-SEC)	16 µA (typ.)
<b>Environment</b>		
Ambient temperature max.	40 °C	
<b>Safety and protection</b>		
Type	Enclosed	
Class of Insulation System	A	
Protection index	IP 44	
Safety class	I	
Insulation res. (PRI-PE)	>10 GΩ (typ.)	
Insulation res. (PRI-SEC)	>10 GΩ (typ.)	
Coupling cap. (PRI-SEC)	172 pF (typ.)	
Magn. 50 Hz stray f. (Encl.)	0.33 mT (typ.)	
Short circuit strength	non-inherently short-circuit proof	
Test voltage	4000 Vac, 50 Hz	
<b>Order numbers</b>		
<b>Order Number</b>	<b>STT 100</b>	

Type		STT 100
<b>Mechanical data</b>	<b>Terminal and mounting</b>	
	Terminals Input	Mains connecting cable with safety plug
	Terminals Output	Protective contact socket
	<b>Measures and weights</b>	
	Weight	5.10 kg
	Dimensions W x H x D	105 x 125 x 170 mm

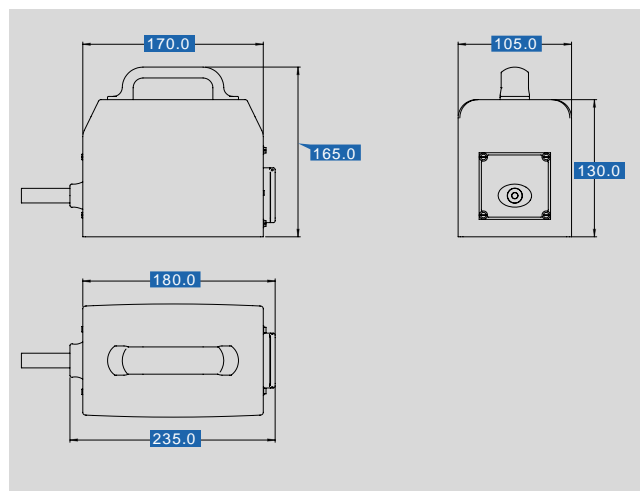

Subjects to change.



**Automatización Eléctrica**  
Especialistas en Automatización

Below is a list of articles with direct links to our shop Electric Automation Network where you can see:

- Quote per purchase volume in real time.
- Online documentation and datasheets of all products.
- Estimated delivery time enquiry in real time.
- Logistics systems for the shipment of materials almost anywhere in the world.
- Purchasing management, order record and tracking of shipments.

To access the product, [click on the green button.](#)

<b>Product</b>	<b>Code</b>	<b>Reference</b>	<b>Product link</b>
Interference suppressing transformer enclosed, encapsulated, portable, PRI 230 Vac, SEC 100 - 400 VA, 230 Vac	STT100	STT 100	<a href="#">Buy on EAN</a>