



**Automatización Eléctrica**

Especialistas en Automatización

At the end of this document you will find links to products related to this catalog. You can go directly to our shop by clicking [HERE](#). [HERE](#)

# Three-phase, primary switched mode power supply, Line PVSL 400/24-10



Picture shows PVSL 400/24-20

## Advantages

Power input monitoring
LCD
Output current and output voltage monitoring
RS-232 interface
Stabilised and adjustable output voltage
Up to 200 % Real Power Boost for 4 seconds
Top Boost to trip conventional circuit breakers
3 LEDs and active signal outputs to indicate operating status
Parallel connection option
Service-friendly spring-loaded connector system
Can be supplied with active inrush current limiting
Panel installation on mounting rails

## Applications

Primary switch mode power supply with high power reserves for all automation requirements with a variety of parameter setting and display functions, including output current and output voltage monitoring. Intelligent additional functions for the input power to replace a variety of external devices such as diagnostic voltmeter, phase meter, hour meter.

## Sample application

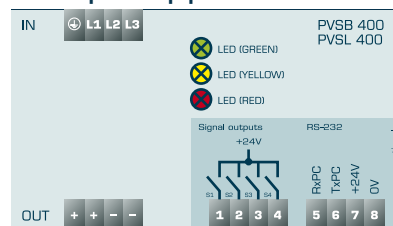

## Standards

Primary switched mode power supply  
to UL 60950, UL 508

Safety:  
EN 61558-2-16, EN 60950-1

EMC:  
EN 61204-3

## Approvals



UL/CSA 60950 recognised, UL508 listed



# Three-phase, primary switched mode power supply, Line PVSL 400/24-10

Type	PVSL 400/24-10
<b>Electrical data</b>	
<b>Input</b>	
Input rated voltage	3 x 400 - 500 Vac
Input voltage range	340 - 550 Vac (480 - 780 Vdc)
Input rated current (rated load)	0.6 A (3 x 340 Vac)
Rated frequency range	44 Hz - 66 Hz / 0 Hz
Starting current limiter	<30 A, NTC
Input fuse internal	3 x 1.6 A (slow-blow)
Recommended back-up fuse (circuit breaker)	6 A, 10 A, 16 A, characteristics B, C
Harmonic correction	passive
Mains buffering (rated load)	22.6 / 51.5 ms (400 / 500 Vac)
Transient surge voltage protection	Varistor
<b>Output</b>	
Output rated voltage	24 Vdc $\pm$ 1 %
Output voltage range	22.8 - 28.8 Vdc
Resistance to reverse feed max.	35 Vdc
Output rated current	10.00 A
Parallel connection	Yes
Power Boost	20 A / 4 s (15 A / 8 s)
Overload behaviour	Constant current or fuse
Efficiency	typ. 91.7 %
Ripple factor	typ. 70 mVss
Top Boost	70 A / 50 ms
<b>Signaling</b>	
Power Good (DC OK)	LED green, LED red, LED yellow
Active signal outputs	4 x 24 Vdc, 2 configurable
Stand-by-input	No
Display, interface	Yes, RS 232
<b>Approvals</b>	
Approvals	cURus, cULus
<b>Environment</b>	
Ambient temperature	-25° C to +70° C
Storage temperature	-25 °C to +85 °C
Derating	-3 %/K > +50° C
<b>Safety and protection</b>	
Protection index	IP 20
Safety class	I, with PE connection
<b>Accessory</b>	
Connector for signalling	PV-CON (optional)
Adapter cable for interface	PV-KOK2 (optional)
Side DIN Rail mounting	PV-TS35M (optional)
Direct screw fastening plate for lateral mounting	PV-WB2 (optional)
<b>Order numbers</b>	
<b>Order Number</b>	<b>PVSL 400/24-10</b>

Type	PVSL 400/24-10
<b>Mechanical data</b>	
<b>Terminal and mounting</b>	
Terminals input, (spring clamp terminal, pluggable)	max. 2.5 mm <sup>2</sup>
Terminals output, (spring clamp terminal, pluggable)	max. 2.5 mm <sup>2</sup>
Terminals signalling, (spring clamp terminal, pluggable)	max. 0.5 mm <sup>2</sup>
Mounting position	vertical
Fixing method	DIN Rail system TH 35
<b>Measures and weights</b>	
Weight	1.30 kg

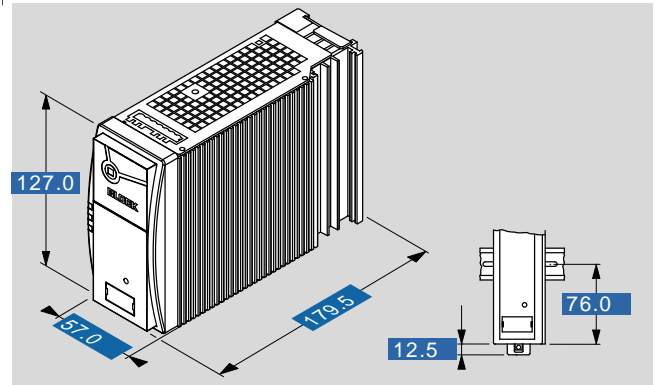

Subjects to change.

Below is a list of articles with direct links to our shop Electric Automation Network where you can see:

- Quote per purchase volume in real time.
- Online documentation and datasheets of all products.
- Estimated delivery time enquiry in real time.
- Logistics systems for the shipment of materials almost anywhere in the world.
- Purchasing management, order record and tracking of shipments.

To access the product, [click on the green button.](#)

<b>Product</b>	<b>Code</b>	<b>Reference</b>	<b>Product link</b>
Three-phase, primary switched mode power supply, Line Line monitoring, control unit, PRI 3 x 400 - 500 Vac, SEC 10 - 40 A, 24 Vdc, Top Boost, Real Power Boost	PVSL4002410	PVSL 400/24-10	<a href="#">Buy on EAN</a>