



**Main switch, T5B, 63 A, flush mounting, 8 contact unit(s), 15-pole, Emergency switching off function, With red rotary handle and yellow locking ring**



**Part no. T5B-8-8351/EA/SVB**  
**Catalog No. 091228**

**Delivery program**

Product range		Main switch maintenance switch Repair switch																																																																																													
Part group reference		T5B																																																																																													
Stop Function		Emergency switching off function																																																																																													
		With red rotary handle and yellow locking ring																																																																																													
Number of poles		15-pole																																																																																													
Degree of Protection		Front IP65																																																																																													
Design		flush mounting																																																																																													
Contact sequence		<table border="1"> <thead> <tr> <th></th> <th>0</th> <th>1</th> </tr> </thead> <tbody> <tr><td>1 ○</td><td></td><td>X</td></tr> <tr><td>2 ○</td><td></td><td>X</td></tr> <tr><td>3 ○</td><td></td><td>X</td></tr> <tr><td>4 ○</td><td></td><td>X</td></tr> <tr><td>5 ○</td><td></td><td>X</td></tr> <tr><td>6 ○</td><td></td><td>X</td></tr> <tr><td>7 ○</td><td></td><td>X</td></tr> <tr><td>8 ○</td><td></td><td>X</td></tr> <tr><td>9 ○</td><td></td><td>X</td></tr> <tr><td>10 ○</td><td></td><td>X</td></tr> <tr><td>11 ○</td><td></td><td>X</td></tr> <tr><td>12 ○</td><td></td><td>X</td></tr> <tr><td>13 ○</td><td></td><td>X</td></tr> <tr><td>14 ○</td><td></td><td>X</td></tr> <tr><td>15 ○</td><td></td><td>X</td></tr> <tr><td>16 ○</td><td></td><td>X</td></tr> <tr><td>17 ○</td><td></td><td>X</td></tr> <tr><td>18 ○</td><td></td><td>X</td></tr> <tr><td>19 ○</td><td></td><td>X</td></tr> <tr><td>20 ○</td><td></td><td>X</td></tr> <tr><td>21 ○</td><td></td><td>X</td></tr> <tr><td>22 ○</td><td></td><td>X</td></tr> <tr><td>23 ○</td><td></td><td>X</td></tr> <tr><td>24 ○</td><td></td><td>X</td></tr> <tr><td>25 ○</td><td></td><td>X</td></tr> <tr><td>26 ○</td><td></td><td>X</td></tr> <tr><td>27 ○</td><td></td><td>X</td></tr> <tr><td>28 ○</td><td></td><td>X</td></tr> <tr><td>29 ○</td><td></td><td>X</td></tr> <tr><td>30 ○</td><td></td><td>X</td></tr> </tbody> </table>		0	1	1 ○		X	2 ○		X	3 ○		X	4 ○		X	5 ○		X	6 ○		X	7 ○		X	8 ○		X	9 ○		X	10 ○		X	11 ○		X	12 ○		X	13 ○		X	14 ○		X	15 ○		X	16 ○		X	17 ○		X	18 ○		X	19 ○		X	20 ○		X	21 ○		X	22 ○		X	23 ○		X	24 ○		X	25 ○		X	26 ○		X	27 ○		X	28 ○		X	29 ○		X	30 ○		X
	0	1																																																																																													
1 ○		X																																																																																													
2 ○		X																																																																																													
3 ○		X																																																																																													
4 ○		X																																																																																													
5 ○		X																																																																																													
6 ○		X																																																																																													
7 ○		X																																																																																													
8 ○		X																																																																																													
9 ○		X																																																																																													
10 ○		X																																																																																													
11 ○		X																																																																																													
12 ○		X																																																																																													
13 ○		X																																																																																													
14 ○		X																																																																																													
15 ○		X																																																																																													
16 ○		X																																																																																													
17 ○		X																																																																																													
18 ○		X																																																																																													
19 ○		X																																																																																													
20 ○		X																																																																																													
21 ○		X																																																																																													
22 ○		X																																																																																													
23 ○		X																																																																																													
24 ○		X																																																																																													
25 ○		X																																																																																													
26 ○		X																																																																																													
27 ○		X																																																																																													
28 ○		X																																																																																													
29 ○		X																																																																																													
30 ○		X																																																																																													

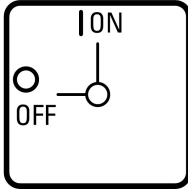
Switching angle		°	90
Design number			8351
Function			
<b>Motor rating AC-23A, 50 - 60 Hz</b>			
400 V	P	kW	30
Rated uninterrupted current	$I_u$	A	63
Note on rated uninterrupted current $I_u$			Rated uninterrupted current $I_u$ is specified for max. cross-section.
Number of contact units		contact unit(s)	8

## Technical data

### General

Standards			IEC/EN 60947, VDE 0660, IEC/EN 60204, CSA, UL Switch-disconnector according to IEC/EN 60947-3
Climatic proofing			Damp heat, constant, to IEC 60068-2-78 Damp heat, cyclic, to IEC 60068-2-30
Ambient temperature			
Open		°C	-25 - +50
Enclosed		°C	-25 - +40
Overvoltage category/pollution degree			III/3
Rated impulse withstand voltage	$U_{imp}$	V AC	6000
Mechanical shock resistance		g	15
Mounting position			As required

### Contacts

Mechanical variables			
Number of poles			15-pole
Electrical characteristics			
Rated operational voltage	$U_e$	V AC	690
Rated uninterrupted current	$I_u$	A	63
Note on rated uninterrupted current $I_u$			Rated uninterrupted current $I_u$ is specified for max. cross-section.
Load rating with intermittent operation, class 12			
AB 25 % DF		$x I_e$	2
AB 40 % DF		$x I_e$	1.6
AB 60 % DF		$x I_e$	1.3
Short-circuit rating			
Fuse		A gG/gL	80
Rated short-time withstand current (1 s current)	$I_{cw}$	$A_{rms}$	1300
Note on rated short-time withstand current $I_{cw}$			Current for a time of 1 second
Rated conditional short-circuit current	$I_q$	kA	2

### Switching capacity

$\cos \varphi$ rated making capacity as per IEC 60947-3		A	800
Rated breaking capacity $\cos \varphi$ to IEC 60947-3		A	
230 V		A	520
400/415 V		A	600
500 V		A	480
690 V		A	340
Safe isolation to EN 61140			
between the contacts		V AC	440
Current heat loss per contact at $I_e$		W	4.5
Current heat loss per auxiliary circuit at $I_e$ (AC-15/230 V)		CO	4.5
Lifespan, mechanical	Operations	$x 10^6$	> 0.5

Maximum operating frequency	Operations/h		1200
<b>AC</b>			
<b>AC-3</b>			
Rating, motor load switch	P	kW	
220 V 230 V	P	kW	15
230 V Star-delta	P	kW	18.5
400 V 415 V	P	kW	22
400 V Star-delta	P	kW	30
500 V	P	kW	22
500 V Star-delta	P	kW	37
690 V	P	kW	15
690 V Star-delta	P	kW	22
Rated operational current motor load switch			
230 V	I <sub>e</sub>	A	51
230 V star-delta	I <sub>e</sub>	A	63
400V 415 V	I <sub>e</sub>	A	41
400 V star-delta	I <sub>e</sub>	A	63
500 V	I <sub>e</sub>	A	33
500 V star-delta	I <sub>e</sub>	A	57.2
690 V	I <sub>e</sub>	A	17
690 V star-delta	I <sub>e</sub>	A	29.4
<b>AC-21A</b>			
Rated operational current switch			
440 V	I <sub>e</sub>	A	63
<b>AC-23A</b>			
Motor rating AC-23A, 50 - 60 Hz			
230 V	P	kW	18.5
400 V 415 V	P	kW	30
500 V	P	kW	22
690 V	P	kW	22
Rated operational current motor load switch			
230 V	I <sub>e</sub>	A	63
400 V 415 V	I <sub>e</sub>	A	63
500 V	I <sub>e</sub>	A	33
690 V	I <sub>e</sub>	A	23.8
<b>DC</b>			
<b>DC-1, Load-break switches L/R = 1 ms</b>			
Rated operational current	I <sub>e</sub>	A	63
Voltage per contact pair in series		V	60
<b>DC-23A, motor load switch L/R = 15 ms</b>			
<b>24 V</b>			
Rated operational current	I <sub>e</sub>	A	50
Contacts		Quantity	1
<b>48 V</b>			
Rated operational current	I <sub>e</sub>	A	50
Contacts		Quantity	2
<b>60 V</b>			
Rated operational current	I <sub>e</sub>	A	50
Contacts		Quantity	3
<b>120 V</b>			
Rated operational current	I <sub>e</sub>	A	25
Contacts		Quantity	3
<b>240 V</b>			
Rated operational current	I <sub>e</sub>	A	20

Contacts		Quantity	6
DC-13, Control switches L/R = 50 ms			
Rated operational current	I <sub>e</sub>	A	25
Voltage per contact pair in series		V	24
Control circuit reliability at 24 V DC, 10 mA	Fault probability	H <sub>F</sub>	< 10 <sup>-5</sup> , < 1 failure in 100,000 switching operations

### Terminal capacities

Solid or stranded		mm <sup>2</sup>	1 x (2,5 - 35) 2 x (2,5 - 16)
Flexible with ferrules to DIN 46228		mm <sup>2</sup>	1 x (1 - 25) 2 x (1.5 - 10)
Terminal screw			M6
Tightening torque for terminal screw		Nm	4

### Technical safety parameters:

<b>Notes</b>			B10 <sub>d</sub> values as per EN ISO 13849-1, table C1
--------------	--	--	---

### Rating data for approved types

Contacts			
Rated operational voltage	U <sub>e</sub>	V AC	600
Rated uninterrupted current max.			
Main conducting paths			
General use		A	63
Switching capacity			
Maximum motor rating			
Single-phase			
120 V AC		HP	3
200 V AC		HP	7.5
240 V AC		HP	10
Three-phase			
200 V AC		HP	15
240 V AC		HP	15
480 V AC		HP	40
600 V AC		HP	40
Short Circuit Current Rating		SCCR	
High fault rating		kA	10
max. Fuse		A	100, Class J
Terminal capacity			
Solid or flexible conductor with ferrule		AWG	12 - 4
Terminal screw			M6
Tightening torque		lb-in	35.4

### Design verification as per IEC/EN 61439

Technical data for design verification			
Rated operational current for specified heat dissipation	I <sub>n</sub>	A	63
Heat dissipation per pole, current-dependent	P <sub>vid</sub>	W	4.5
Equipment heat dissipation, current-dependent	P <sub>vid</sub>	W	0
Static heat dissipation, non-current-dependent	P <sub>vs</sub>	W	0
Heat dissipation capacity	P <sub>diss</sub>	W	0
Operating ambient temperature min.		°C	-25
Operating ambient temperature max.		°C	50
IEC/EN 61439 design verification			
10.2 Strength of materials and parts			
10.2.2 Corrosion resistance			Meets the product standard's requirements.
10.2.3.1 Verification of thermal stability of enclosures			Meets the product standard's requirements.
10.2.3.2 Verification of resistance of insulating materials to normal heat			Meets the product standard's requirements.
10.2.3.3 Verification of resistance of insulating materials to abnormal heat and fire due to internal electric effects			Meets the product standard's requirements.
10.2.4 Resistance to ultra-violet (UV) radiation			UV resistance only in connection with protective shield.

10.2.5 Lifting		Does not apply, since the entire switchgear needs to be evaluated.
10.2.6 Mechanical impact		Does not apply, since the entire switchgear needs to be evaluated.
10.2.7 Inscriptions		Meets the product standard's requirements.
10.3 Degree of protection of ASSEMBLIES		Does not apply, since the entire switchgear needs to be evaluated.
10.4 Clearances and creepage distances		Meets the product standard's requirements.
10.5 Protection against electric shock		Does not apply, since the entire switchgear needs to be evaluated.
10.6 Incorporation of switching devices and components		Does not apply, since the entire switchgear needs to be evaluated.
10.7 Internal electrical circuits and connections		Is the panel builder's responsibility.
10.8 Connections for external conductors		Is the panel builder's responsibility.
10.9 Insulation properties		
10.9.2 Power-frequency electric strength		Is the panel builder's responsibility.
10.9.3 Impulse withstand voltage		Is the panel builder's responsibility.
10.9.4 Testing of enclosures made of insulating material		Is the panel builder's responsibility.
10.10 Temperature rise		The panel builder is responsible for the temperature rise calculation. Eaton will provide heat dissipation data for the devices.
10.11 Short-circuit rating		Is the panel builder's responsibility. The specifications for the switchgear must be observed.
10.12 Electromagnetic compatibility		Is the panel builder's responsibility. The specifications for the switchgear must be observed.
10.13 Mechanical function		The device meets the requirements, provided the information in the instruction leaflet (IL) is observed.

## Technical data ETIM 7.0

Low-voltage industrial components (EG000017) / Switch disconnecter (EC000216)

Electric engineering, automation, process control engineering / Low-voltage switch technology / Off-load switch, circuit breaker, control switch / Switch disconnecter (ecl@ss10.0.1-27-37-14-03 [AKF060013])

Version as main switch		Yes
Version as maintenance-/service switch		Yes
Version as safety switch		No
Version as emergency stop installation		Yes
Version as reversing switch		No
Number of switches		1
Max. rated operation voltage Ue AC	V	690
Rated operating voltage	V	690 - 690
Rated permanent current Iu	A	63
Rated permanent current at AC-23, 400 V	A	63
Rated permanent current at AC-21, 400 V	A	63
Rated operation power at AC-3, 400 V	kW	22
Rated short-time withstand current Icw	kA	1.3
Rated operation power at AC-23, 400 V	kW	30
Switching power at 400 V	kW	30
Conditioned rated short-circuit current Iq	kA	2
Number of poles		15
Number of auxiliary contacts as normally closed contact		0
Number of auxiliary contacts as normally open contact		0
Number of auxiliary contacts as change-over contact		0
Motor drive optional		No
Motor drive integrated		No
Voltage release optional		No
Device construction		Built-in device fixed built-in technique
Suitable for ground mounting		No
Suitable for front mounting 4-hole		No
Suitable for front mounting centre		Yes
Suitable for distribution board installation		No
Suitable for intermediate mounting		No
Colour control element		Red
Type of control element		Door coupling rotary drive

Interlockable		Yes
Type of electrical connection of main circuit		Screw connection
Degree of protection (IP), front side		IP65
Degree of protection (NEMA)		12

## Approvals

Product Standards		UL 60947-4-1; CSA - C22.2 No. 60947-4-1-14; CSA-C22.2 No. 94; IEC/EN 60947-3; CE marking
UL File No.		E36332
UL Category Control No.		NLRV
CSA File No.		12528
CSA Class No.		3211-05
North America Certification		UL listed, CSA certified
Suitable for		Branch circuits, suitable as motor disconnect
Degree of Protection		IEC: IP65; UL/CSA Type 1, 12

## Dimensions

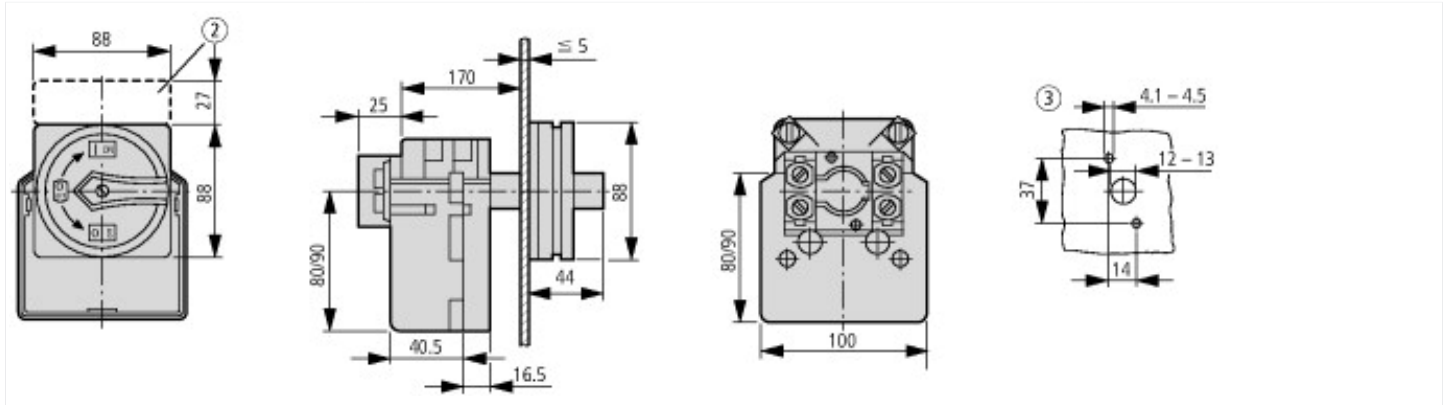

② ZFS... Label mount not included as standard

③ Drilling dimensions door

Cam switches T5B and T5 are of identical design, only their contacts are different

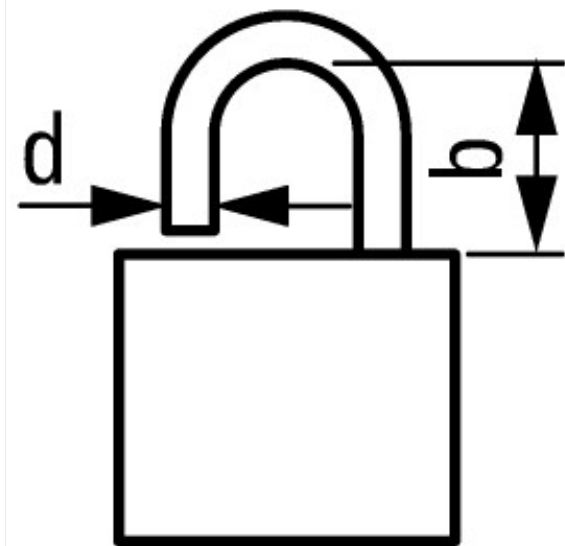

$$d = 4 - 8 \text{ mm}$$

$$b + d \leq 47 \text{ mm}$$

$$d = 0.16 - 0.31''$$

$$b + d \leq 1.85''$$

≤ 3 padlocks

## Assets (links)

### Declaration of CE Conformity

00003073

### Instruction Leaflets

IL03801009Z2018\_05

## Additional product information (links)

IL03801009Z (AWA1150-1692) Cam switches: switch-disconnectors

IL03801009Z (AWA1150-1692) Cam switches: switch-disconnectors	<a href="ftp://ftp.moeller.net/DOCUMENTATION/AWA_INSTRUCTIONS/IL03801009Z2018_05.pdf">ftp://ftp.moeller.net/DOCUMENTATION/AWA_INSTRUCTIONS/IL03801009Z2018_05.pdf</a>
Display flip catalog page.	<a href="http://ecat.moeller.net/flip-cat/?edition=K115A&amp;startpage=130">http://ecat.moeller.net/flip-cat/?edition=K115A&amp;startpage=130</a>
Technical overview cam switch, switch-disconnector	<a href="http://de.ecat.moeller.net/flip-cat/?edition=HPLTEv1&amp;startpage=4.2">http://de.ecat.moeller.net/flip-cat/?edition=HPLTEv1&amp;startpage=4.2</a>
System overview cam switch T	<a href="http://de.ecat.moeller.net/flip-cat/?edition=HPLTEv1&amp;startpage=4.4">http://de.ecat.moeller.net/flip-cat/?edition=HPLTEv1&amp;startpage=4.4</a>
System overview switch-disconnector P	<a href="http://de.ecat.moeller.net/flip-cat/?edition=HPLTEv1&amp;startpage=4.6">http://de.ecat.moeller.net/flip-cat/?edition=HPLTEv1&amp;startpage=4.6</a>
Key to part numbers Cam switch	<a href="http://de.ecat.moeller.net/flip-cat/?edition=HPLTEv1&amp;startpage=4.8">http://de.ecat.moeller.net/flip-cat/?edition=HPLTEv1&amp;startpage=4.8</a>
Key to part numbers Switch-disconnector	<a href="http://de.ecat.moeller.net/flip-cat/?edition=HPLTEv1&amp;startpage=4.8">http://de.ecat.moeller.net/flip-cat/?edition=HPLTEv1&amp;startpage=4.8</a>
Switches for ATEX	<a href="http://www.coopercrouse-hinds.eu/en/products/25-ex-safety-and-main-current-switches.html">http://www.coopercrouse-hinds.eu/en/products/25-ex-safety-and-main-current-switches.html</a>
Ordering form for SOND switches and SOND front plates(DE_EN)	<a href="ftp://ftp.moeller.net/DOCUMENTATION/PDF/MZ008005ZU_Orderform_Customized_Switch.pdf">ftp://ftp.moeller.net/DOCUMENTATION/PDF/MZ008005ZU_Orderform_Customized_Switch.pdf</a>
Ordering form for SOND switches and SOND front plates(DE_EN)	<a href="ftp://ftp.moeller.net/DOCUMENTATION/PDF/MZ008006ZU_Orderform_Customized_Switch.pdf">ftp://ftp.moeller.net/DOCUMENTATION/PDF/MZ008006ZU_Orderform_Customized_Switch.pdf</a>