



Analog I/O module for XC100/200, 24 V DC, 2AI, 1AO(0-10V)

Part no. XIOC-2AI-1AO-U1
Catalog No. 262409
EL-Nummer (Norway) 4519679

Delivery program

Function		Analog modules
Description		Compact I/O system for connection to XC100/200 Modular PLCs XC100/200 expandable with up to 15 XI/OC modules Optionally, screw terminals or spring-loaded terminals for digital/analog modules Combination modules 2 Inputs and 1 Output 0 - 10 V 1 ms conversion time

Technical data

General

Standards		IEC/EN 61131-2 EN 50178
Ambient temperature		°C 0 - +55
Storage	θ	°C -25 - +70
Vibration resistance		10 - 57 Hz ±0.075 mm 57 - 150 Hz ±1.0 mm
Mechanical shock resistance		g 15 Shock duration 11 ms
Impact resistance		500 g/∅ 50 mm ±25 g
Overvoltage category/pollution degree		II/2
Protection class		1
Degree of Protection		IP20
Emitted interference		DIN/EN 55011/22, Class A
Weight		kg 0.16

Power supply

Rated voltage	U _e	V DC	24 (12)
Admissible range			20.4 – 28.8 (11.8 – 14.4)
Residual ripple		%	≤ 5
Neutral poles			
Duration of dip		ms	10
Repetition rate		s	1
Maximum power loss	P _v	W	1

Inputs

Input voltage		V DC	0 - 10
Resolution		Bit	14
Conversion time			< 1 ms
Total error		%	Normally 0.4
Input impedance		kΩ	40
Potential isolation			
Circuit within each channel			No
Between the input channels			No
Between input/output channels			No
Input channels		Qty.	2
Internal current consumption (5 V DC)		mA	Normally 100
Terminations			Plug-in terminal block

Resolution	Bit	12
Outputs		
Output voltage	V DC	0 - 10
Resolution	Bit	12
Error		Normally 0.4
Potential isolation		
Circuit within each channel		No
between channels		No
Quantity of channels		1
External load resistance		≤ 2 kΩ
Terminations		Plug-in terminal block
Short-circuit rating		Yes
Internal current consumption (5 V DC)	mA	200

Design verification as per IEC/EN 61439

Technical data for design verification			
Rated operational current for specified heat dissipation	I _n	A	0
Heat dissipation per pole, current-dependent	P _{vid}	W	0
Equipment heat dissipation, current-dependent	P _{vid}	W	0
Static heat dissipation, non-current-dependent	P _{vs}	W	1
Heat dissipation capacity	P _{diss}	W	0
Operating ambient temperature min.		°C	0
Operating ambient temperature max.		°C	55
IEC/EN 61439 design verification			
10.2 Strength of materials and parts			
10.2.2 Corrosion resistance			
10.2.3.1 Verification of thermal stability of enclosures			
10.2.3.2 Verification of resistance of insulating materials to normal heat			
10.2.3.3 Verification of resistance of insulating materials to abnormal heat and fire due to internal electric effects			
10.2.4 Resistance to ultra-violet (UV) radiation			
10.2.5 Lifting			
10.2.6 Mechanical impact			
10.2.7 Inscriptions			
10.3 Degree of protection of ASSEMBLIES			
10.4 Clearances and creepage distances			
10.5 Protection against electric shock			
10.6 Incorporation of switching devices and components			
10.7 Internal electrical circuits and connections			
10.8 Connections for external conductors			
10.9 Insulation properties			
10.9.2 Power-frequency electric strength			
10.9.3 Impulse withstand voltage			
10.9.4 Testing of enclosures made of insulating material			
10.10 Temperature rise			
10.11 Short-circuit rating			
10.12 Electromagnetic compatibility			
10.13 Mechanical function			

Technical data ETIM 7.0

PLC's (EG000024) / PLC analogue I/O-module (EC001420)		
Electric engineering, automation, process control engineering / Control / Programmable logic control (SPS) / SPS analog input/output module (ecl@ss10.0.1-27-24-22-01 [AKE524014])		
Number of analogue inputs		2
Number of analogue outputs		1

Analogue inputs configurable			Yes
Analogue outputs configurable			Yes
Input, current			No
Input, voltage			Yes
Input, resistor			No
Input, resistance thermometer			No
Input, thermocouple			No
Input signal, configurable			No
Resolution of the analogue inputs		Bit	14
Output, current			No
Output, voltage			Yes
Output signal configurable			No
Resolution of the analogue outputs		Bit	12
Type of electric connection			Screw-/spring clamp connection
Suitable for safety functions			No
Category according to EN 954-1			
SIL according to IEC 61508			None
Performance level acc. EN ISO 13849-1			None
Appendant operation agent (Ex ia)			No
Appendant operation agent (Ex ib)			No
Explosion safety category for gas			None
Explosion safety category for dust			None
Width		mm	30
Height		mm	100
Depth		mm	95

Approvals

Product Standards			IEC: see Technical Data; UL508; CSA-C22.2 No. 0-M; CSA-C22.2 No. 142-M; CE marking
UL File No.			E135462
UL Category Control No.			NRAQ
CSA File No.			012528
CSA Class No.			2252-01
North America Certification			UL listed, CSA certified
Specially designed for North America			No
Current Limiting Circuit-Breaker			No
Degree of Protection			IEC: IP20, UL/CSA Type: -

Dimensions

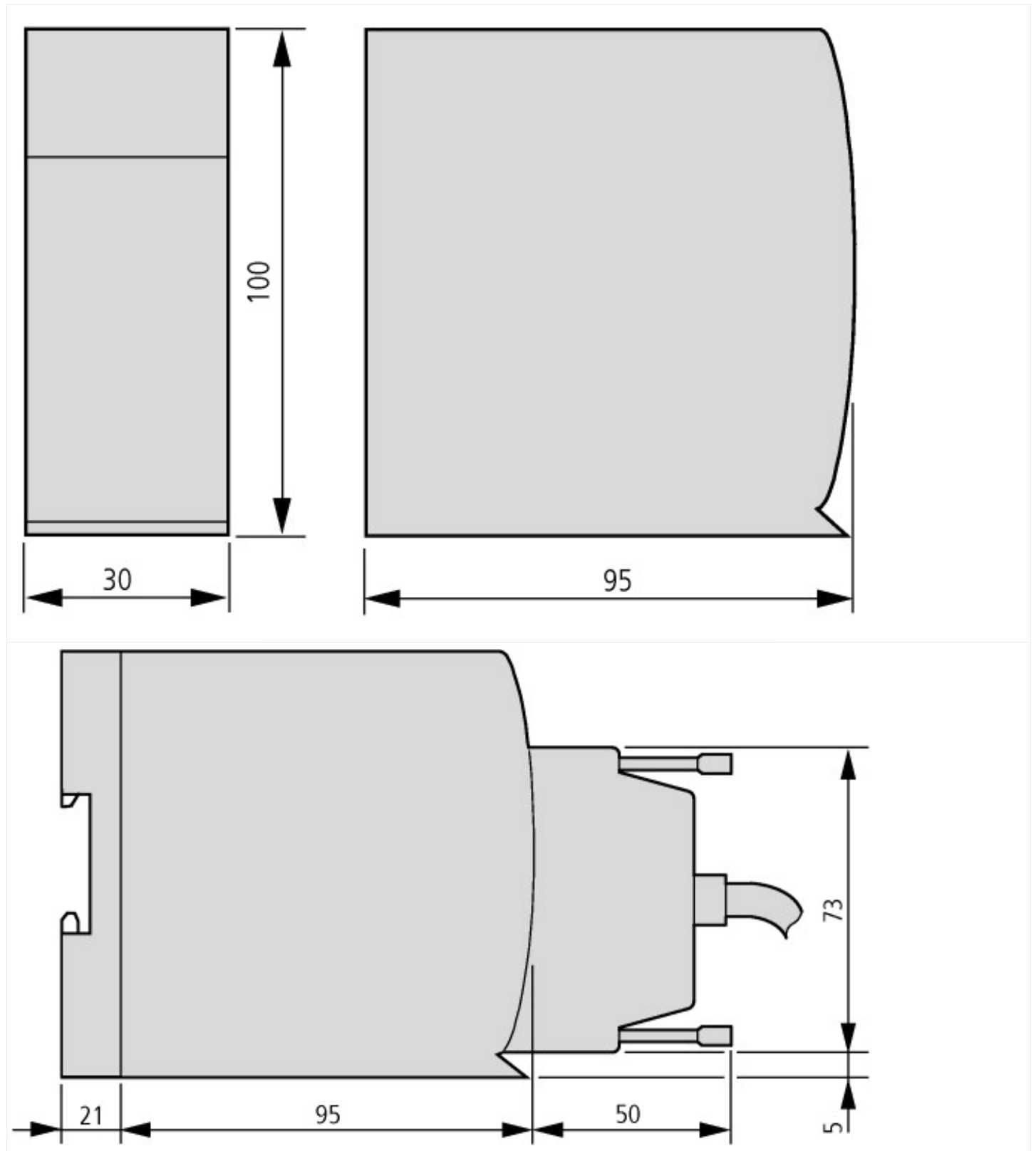

Additional product information (links)

Manual XIOC signal module MN05002002Z (AWB2725-1452)

Handbuch Signalmodul XIOC MN05002002Z
(AWB2725-1452) - Deutsch

https://es-assets.eaton.com/DOCUMENTATION/AWB_MANUALS/MN05002002Z_DE.pdf

Manual XIOC signal module MN05002002Z
(AWB2725-1452) - English

https://es-assets.eaton.com/DOCUMENTATION/AWB_MANUALS/MN05002002Z_EN.pdf