



Proximity switch, E57 Premium+ Short-Series, 1 N/O, 3-wire, 6 - 48 V DC, M12 x 1 mm, S<sub>n</sub> = 2 mm, Flush, PNP, Stainless steel, Plug-in connection M12 x 1

**Part no.** E57SAL12T111SD  
**Catalog No.** 136105  
**Alternate Catalog No.** E57SAL12T111SD

### Delivery program

Basic function			Inductive Sensors
Product range			E57 Premium+ Short-Series
Connection			3-wire
Design (outer dimensions)		mm	M12 x 1
Rated operational voltage	U <sub>e</sub>		6 - 48 V DC
Rated switching distance	S <sub>n</sub>	mm	2
Type of mounting			Flush
Switching type			PNP
For connection of:			Plug-in connection M12 x 1
<b>Contacts</b>			
N/O = Normally open			1 N/O
Material			Stainless steel
Degree of Protection			IP67

### Technical data

#### General

Standards			IEC/EN 60947-5-2
Ambient temperature			-25 - +70
Mechanical shock resistance		g	30 Shock duration 11 ms
Degree of Protection			IP67

#### Characteristics

Rated switching distance			
Rated switching distance	S <sub>n</sub>	mm	2
Repetition accuracy of S <sub>n</sub>		%	1
Temperature drift of S <sub>n</sub>		%	10
Switching hysteresis of S <sub>n</sub>		%	15
Rated operational voltage	U <sub>e</sub>		6 - 48 V DC
Maximum load current	I <sub>e</sub>	mA	< 500 (6 - 32 V DC) / 250 (32 - 48 V DC)
Voltage drop at I <sub>e</sub>	U <sub>d</sub>	V	12
Switching Frequency		Hz	800
Min. load current	I <sub>e</sub>	mA	5
Residual current through the load in the blocked state at 230 V AC and 24 V DC	I <sub>r</sub>	mA	2
Switching state display		LED	Red
Connection			3-wire
Contacts			
N/O = Normally open			1 N/O
Style			
Design (outer dimensions)		mm	M12 x 1
For connection of:			Plug-in connection M12 x 1
Material			Stainless steel

### Design verification as per IEC/EN 61439

Technical data for design verification			
--	--	--	--

Operating ambient temperature min.	°C	-25
Operating ambient temperature max.	°C	70

## Technical data ETIM 7.0

Sensors (EG000026) / Inductive proximity switch (EC002714)

Electric engineering, automation, process control engineering / Binary sensor technology, safety-related sensor technology / Proximity switch / Inductive proximity switch (ec@ss10.0.1-27-27-01-01 [AGZ376015])

Width sensor	mm	0
Height of sensor	mm	0
Length of sensor	mm	41
Diameter sensor	mm	12
Mechanical mounting condition for sensor		Concise
Switching distance	mm	2
Suitable for safety functions		No
Type of switch function		Normally open contact
Type of switching output		PNP
Type of electric connection		Connector M12
Number of semiconductor outputs with signalling function		1
Number of contact energized outputs with signalling function		0
Number of protected semiconductor outputs		0
Number of protected contact energized outputs		0
Type of actuation		Metallic Target
Type of interface		None
Type of interface for safety communication		None
Construction type housing		Cylinder, screw-thread
Coating housing		Other
Cascadable		No
Category according to EN 954-1		B
SIL according to IEC 61508		None
Performance level acc. EN ISO 13849-1		None
Max. output current at protected output	mA	0
Supply voltage	V	6 - 48
Rated control supply voltage Us at AC 50HZ	V	0 - 0
Rated control supply voltage Us at AC 60HZ	V	0 - 0
Rated control supply voltage Us at DC	V	6 - 48
Voltage type		DC
Switching frequency	Hz	800
With monitoring function downstream switching devices		No
Material housing		Metal
Compression-resistant		No
Explosion safety category for gas		None
Explosion safety category for dust		None
Interference resistance to magnetic fields		

## Approvals

Product Standards		UL 508; CSA-C22.2 No. 14; IEC60947-5-2; CE marking
UL File No.		E166051
UL Category Control No.		NRKH, NRKH7
CSA File No.		50513
CSA Class No.		3211-03
North America Certification		UL listed, CSA certified
Max. Voltage Rating		250 V AC, 250 V DC
Degree of Protection		IEC: IP67; UL/CSA Type: 4, 4x, 6, 6P, 12, 13

## Dimensions

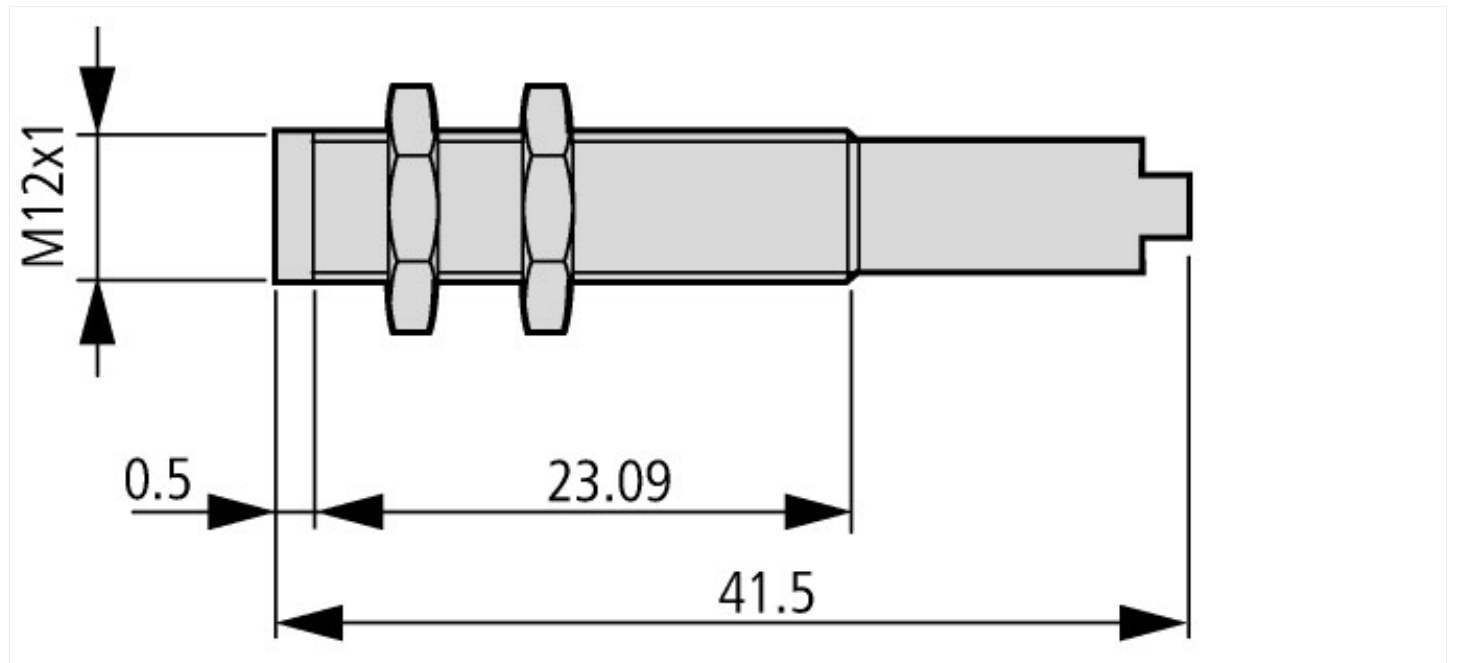

## Assets (links)

### Declaration of CE Conformity

00003158

### Instruction Leaflets

IL05301003Z2018\_05

## Additional product information (links)

### IL05301003Z Premium Plus Series Inductive Sensors +Short, +Miniature

IL05301003Z Premium Plus Series Inductive Sensors +Short, +Miniature [ftp://ftp.moeller.net/DOCUMENTATION/AWA\\_INSTRUCTIONS/IL05301003Z2018\\_05.pdf](ftp://ftp.moeller.net/DOCUMENTATION/AWA_INSTRUCTIONS/IL05301003Z2018_05.pdf)